

Pressure and flow control system

Type SY(H)DFED

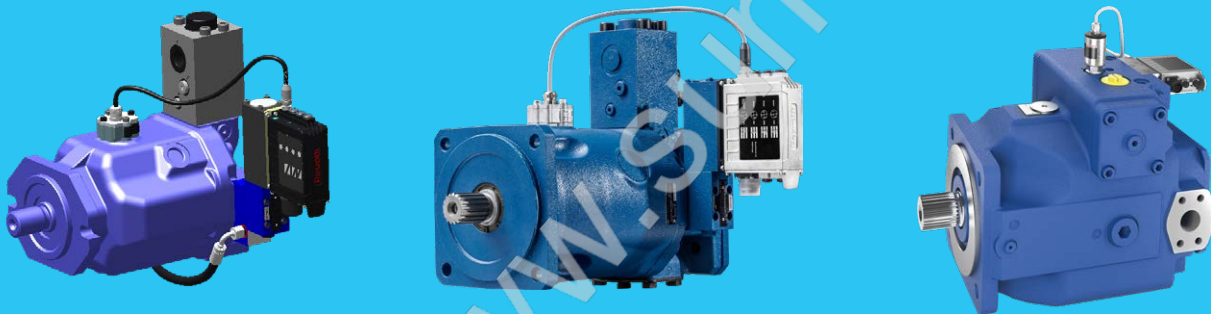

Valid for the following types:

SYDFED series 2X
SYDFED series 3X

SYHDFED series 1X

The data specified only serve to describe the product. If information on the use of the product is given, it is only to be regarded as application examples and recommendations. Catalog specifications do not constitute assured characteristics. The information given does not release the user from the obligation of own judgment and verification. It must be remembered that our products are subject to a natural process of wear and aging.

© This document, as well as the data, specifications and other information set forth in it, are the exclusive property of Bosch Rexroth AG.

It may not be reproduced or given to third parties without its consent.

The cover shows an example configuration. The product delivered may differ from the image on the cover.

Translation of the original operating instructions. The original operating instructions were prepared in German language.

www.summit

Content

| | | |
|----------|--|-----------|
| 1 | About this documentation | 6 |
| 1.1 | Validity of the documentation | 6 |
| 1.2 | Required and supplementary documentation | 6 |
| 1.3 | Representation of information | 7 |
| 1.3.1 | Safety instructions | 7 |
| 1.3.2 | Symbols | 8 |
| 1.3.3 | Designations | 8 |
| 1.3.4 | Abbreviations | 8 |
| 2 | Safety instructions | 10 |
| 2.1 | About this chapter | 10 |
| 2.2 | Intended use | 10 |
| 2.3 | Improper use | 10 |
| 2.4 | Qualification of personnel | 11 |
| 2.5 | General safety instructions | 11 |
| 2.6 | Product- and technology-related safety instructions | 12 |
| 2.7 | Personal protective equipment | 14 |
| 2.8 | Obligations of the machine end-user | 14 |
| 3 | General notes on damage to property and damage to the product | 15 |
| 4 | Scope of delivery | 16 |
| 5 | Product description | 17 |
| 5.1 | Performance description | 17 |
| 5.2 | Device description | 17 |
| 5.2.1 | Functional description, section of SY(H)DFED | 17 |
| 5.3 | Control of the SY(H)DFED control system | 21 |
| 5.3.1 | Structure of the control | 21 |
| 5.3.2 | Controller parameters | 22 |
| 5.3.3 | Controller parameter sets | 22 |
| 5.3.4 | Special operating modes | 23 |
| 5.3.5 | Operating pressure limits | 27 |
| 5.3.6 | Internal/external pilot oil | 27 |
| 5.4 | Ambient conditions | 29 |
| 5.4.1 | Oil-immersed applications | 29 |
| 5.4.2 | Ambient temperature | 29 |
| 5.5 | Notes on the selection of hydraulic fluids | 29 |
| 5.6 | Generation of noise | 31 |
| 5.6.1 | Generation of noise in the power unit | 31 |
| 5.6.2 | Pulsation damper | 31 |
| 5.7 | Shaft variant | 32 |
| 5.8 | Spool variants of pilot valve VT-DFPD-X-1X | 32 |
| 5.9 | Master/slave operation | 33 |
| 5.9.1 | Circuitry of SY(H)DFED | 33 |
| 5.10 | Description of the commissioning tool IndraWorks | 35 |
| 5.10.1 | System requirements | 35 |
| 5.10.2 | Firmware update | 36 |
| 5.11 | Switch-on sequence of electronics/hydraulics | 36 |
| 5.12 | Identification of the product | 37 |
| 6 | Transport and storage | 38 |
| 6.1 | Transporting the SY(H)DFED control system | 38 |
| 6.1.1 | Transport using lifting gear | 39 |
| 6.2 | Storing the SY(H)DFED control system | 40 |

| | | |
|-----------|---|-----------|
| 7 | Installation | 42 |
| 7.1 | Unpacking | 42 |
| 7.2 | Installation conditions | 42 |
| 7.3 | Installation positions and piping of SY(H)DFED systems | 43 |
| 7.3.1 | General information | 43 |
| 7.3.2 | Piping | 44 |
| 7.4 | Installing the SY(H)DFED control system | 46 |
| 7.4.1 | Preparations | 46 |
| 7.4.2 | Dimensions of connections | 47 |
| 7.4.3 | General notes | 47 |
| 7.4.4 | Installation with coupling | 47 |
| 7.4.5 | Completing the installation | 48 |
| 7.5 | Connecting the SY(H)DFEE control system hydraulically | 48 |
| 7.6 | Connecting the SY(H)DFED control system electrically | 52 |
| 7.6.1 | Cabling of electronic components | 52 |
| 7.6.2 | Electrical connection of the pilot valve | 53 |
| 7.6.3 | Connection to the swivel angle sensor | 53 |
| 7.6.4 | X2M1 and X2M2: Analog, configurable sensor interface (coding A), M12, 5-pin, socket | 54 |
| 7.6.5 | X7E1 and X7E2: Plug-in connector pinout for Ethernet interface (coding D), M12, 4-pin, socket | 54 |
| 7.6.6 | LED status indicator lamps | 55 |
| 7.6.7 | Power supply of the VT-DFFD pilot valve | 55 |
| 7.6.8 | Selection, place of installation and mounting orientation of the pressure transducer | 56 |
| 8 | Commissioning | 58 |
| 8.1 | Initial commissioning | 59 |
| 8.1.1 | Filling the SY(H)DFED control system | 59 |
| 8.1.2 | Testing the hydraulic fluid supply | 60 |
| 8.1.3 | Performing a flushing cycle | 60 |
| 8.1.4 | Connection to the control (IndraWorks) | 60 |
| 8.1.5 | Making basic settings on the control electronics | 61 |
| 8.1.6 | Switching on the drive motor of the pump | 64 |
| 8.1.7 | Bleeding the pre-load valve | 65 |
| 8.1.8 | Setting controller parameters | 65 |
| 8.1.9 | Calibrating the SY(H)DFED control system | 70 |
| 8.2 | Recommissioning after standstill | 71 |
| 8.3 | Running-in phase | 72 |
| 9 | Operation | 72 |
| 10 | Maintenance and repair | 73 |
| 10.1 | Cleaning and care | 73 |
| 10.2 | Inspection | 73 |
| 10.3 | Maintenance | 74 |
| 10.4 | Repair | 74 |
| 10.5 | Spare parts | 75 |
| 10.5.1 | Replacement of components | 75 |
| 10.5.2 | Test devices, assembly tools and note on commissioning | 77 |
| 11 | Decommissioning | 77 |
| 12 | Demounting and replacement | 78 |
| 12.1 | Required tools | 78 |
| 12.2 | Preparing demounting | 78 |
| 12.3 | Demounting | 78 |
| 12.4 | Preparing the components for storage or further use | 78 |
| 13 | Disposal | 79 |
| 13.1 | Environmental protection | 79 |
| 13.2 | Return to Bosch Rexroth AG | 79 |
| 13.3 | Packaging | 79 |
| 13.4 | Materials used | 79 |
| 13.5 | Recycling | 80 |

| | | |
|-----------|--|-----------|
| 14 | Extension and modification | 80 |
| 15 | Troubleshooting | 81 |
| 15.1 | How to proceed for troubleshooting | 81 |
| 15.2 | Error/diagnostic memory | 82 |
| 15.2.1 | Error diagnosis | 82 |
| 15.3 | Fault table | 83 |
| 15.3.1 | Swivel angle measurement check | 86 |
| 16 | Technical data | 87 |
| 17 | Annex | 88 |
| 17.1 | List of addresses | 88 |
| 17.2 | Open Source Software | 89 |
| 18 | Alphabetical index | 92 |

www.sumy.ir

1 About this documentation

1.1 VALIDITY OF THE DOCUMENTATION

This documentation is valid for the following pressure/flow control systems:

- SYDFED series 2X
- SYDFED series 3X
- SYHDFED series 1X

This documentation is intended for engineers, fitters, operators, service technicians and plant operators.







This documentation contains important information on the safe and appropriate installation, transport, commissioning, operation, use, maintenance, disassembly and simple troubleshooting of the pressure and flow control systems SYDFED series 2X, 3X and SYHDFED series 1X.

- ▶ Read this documentation thoroughly, especially Chapter 2 “Safety instructions” and Chapter 3 “General notes on damage to property and damage to the product”, before working with the pressure/flow control system.

1.2 REQUIRED AND SUPPLEMENTARY DOCUMENTATION

- ▶ Only commission the product, when you have the documents marked with the book symbol  at hand and have understood and observed them.

Table 1: Required and supplementary documentation

| Title | Document no. | Document type |
|---|--------------|------------------------|
|  Order confirmation | | |
|  Installation drawing | | |
|  General instruction manual for axial piston units | RE 90300-B | Operating instructions |
|  Pressure and flow control system, type SYDFE1, SYDFEE, SYDFED, SYDFEF, component series 2X | RE 30030 | Data sheet |
|  Pressure and flow control system, type SYHDFEE, SYHDFED, SYHDFEF, component series 1X | RE 30035 | Data sheet |
|  Pressure and flow control system, type SYDFE1, SYHDFEE, SYDFED, SYHDFEF, component series 3X | RE 30630 | Data sheet |
| Axial piston variable pump A10VSO series 31, sizes 18 to 100 | RE 92711 | Data sheet |
| Axial piston variable pump A10VSO series 32, sizes 45 to 180 | RE 92714 | Data sheet |
| Axial piston variable pump A4VSO Series 1x and 3x, Size 40...1000 | RE 92050 | Data sheet |
| Axial piston variable pump A4VSO Series 1x and 30 for HFC hydraulic fluids | RE 92053 | Data sheet |
| Fire-resistant hydraulic fluids - containing water (HFAE, HFAS, HFB, HFC) | RE 90223 | Data sheet |
| Hydraulic fluids based on mineral oils and related hydrocarbons | RE 90220 | Data sheet |
| Pump pre-load valve for the SYDFE control system | RE 29255 | Data sheet |
| Proportional directional valves, direct operated, with electrical position feedback as pilot control valve for control systems SY(H)DFE., Type VT-DFP. | RE 29016 | Data sheet |
| Swivel angle sensor, type BAUSATZ VT-SWA-1 | RE 30268 | Data sheet |
| Pressure transducer for hydraulic applications, type HM20 | RE 30272 | Data sheet |
| Pressure transducer for hydraulic applications, type HM20 | RE 30272-B | Operating instructions |

| Title | Document no. | Document type |
|--|--------------|------------------------------------|
| Installation, commissioning and maintenance of hydraulic systems | RE 07900 | Data sheet |
| Rexroth HydraulicDrive HDS-16, HDx17 to HDx-20 Functions | RE 30338-FK | Functional description |
| Rexroth HydraulicDrive HDS-16, HDx17 to HDx-20 Parameters | RE 30330-PA | Parameter description |
| Rexroth HydraulicDrive HDS-16, HDx17 to HDx-20 Diagnostic Messages | RD 30330-WA | Description of diagnostic messages |
| Rexroth HydraulicDrive HDx-20 pump control | RE 30237-Z | Supplementary information |

1.3 REPRESENTATION OF INFORMATION

In order that this documentation allows you to work directly and safely with your product, standardized safety notes, symbols, terms, and abbreviations are used. For a better understanding, they are explained in the following sections.

1.3.1 Safety instructions



In this documentation, safety instructions precede a sequence of activities whenever there is a risk of personal injury or damage to equipment. The hazard avoidance measures described must be observed.

Safety instructions are structured as follows:

|  SIGNAL WORD |
|--|
| <p>Type and source of danger</p> <p>Consequences in case of non-compliance</p> <ul style="list-style-type: none"> ▶ Hazard avoidance measures ▶ <Enumeration> |

- **Warning symbol:** draws attention to a hazard
- **Signal word:** identifies the degree of hazard
- **Type and source of danger:** Specifies the type and source of danger
- **Consequences:** describes the consequences in case of non-compliance
- **Precautions:** states, how the hazard can be avoided

Table 2: Hazard classifications according to ANSI Z535.6-2011

| Warning sign, signal word | Meaning |
|--|--|
|  DANGER | Indicates a hazardous situation which, if not avoided, will certainly result in death or serious injury. |
|  WARNING | Indicates a hazardous situation which, if not avoided, could result in death or serious injury. |
|  CAUTION | Indicates a hazardous situation which, if not avoided, could result in minor or moderate injury. |
| NOTICE | Damage to property: The product or the environment could be damaged. |

1.3.2 Symbols

The following symbols indicate notices which are not safety-relevant but increase the comprehensibility of the documentation.

Table 3: Meaning of the symbols

| Symbol | Meaning |
|---|---|
|  | If this information is disregarded, the product cannot be used or operated in an optimum manner. |
| ▶ | Individual, independent action |
| 1. | Numbered instruction: The numbers indicate that the actions must be carried out one after the other. |
| 2. | |
| 3. | |

1.3.3 Designations

The following terms are used in this documentation:

Table 4: Designations

| Designation | Meaning |
|----------------------|---|
| A10VSO | Axial piston variable displacement pump, open circuit |
| A4VSO | Axial piston variable displacement pump, open circuit |
| HDx | Firmware for HydraulicDrive |
| HM20 | Pressure transducer |
| IndraWorks | Service tool for commissioning, parameterization and diagnostics HydraulicDrive |
| SYDFED-2X | Pressure/flow control system, series 2X |
| SYDFED-3X | Pressure/flow control system, series 3X |
| SYHDFED-1X | Pressure/flow control system, high pressure, series 1X |
| SY(H)DFED | Pressure/flow control system, all series |
| VT-DFP | Pilot valve for SY(H)DFED |
| VT-SWA-1-1X/DFEE-G15 | Swivel angle sensor |

1.3.4 Abbreviations

The following abbreviations are used in this documentation:

Table 5: Abbreviations

| Abbreviation | Meaning |
|-------------------|--|
| DB | Pressure relief valve |
| PT | P ressure T ransducer |
| EMC | E lectromagnetic c ompatibility |
| GND | Ground (signal ground) |
| n.c. | Not connected |
| p | Pressure (symbol) |
| PC | P ersonal C omputer |
| PCV | P recompression V olume |
| p _{Diff} | Control deviation between pressure command value and actual pressure value |
| PE | P rotective E arth |
| p _{act} | Actual pressure value |

| Abbreviation | Meaning |
|---------------------|---|
| p_{comm} | Pressure command value |
| RE | Rexroth document in English language |
| SWA | S wivel A ngle |
| SWA_{act} | Actual swivel angle value |
| SWA_{comm} | Swivel angle command value |
| U_B | Supply voltage |
| VDE | V erband d er E lektrotechnik, E lektronik und I nformationstechnik (Association for electrical, electronic and information technologies) |

www.summy.ir

2 Safety instructions

2.1 ABOUT THIS CHAPTER

The SY(H)DFED control system has been manufactured according to good engineering practice. However, there is still a risk of personal injury and damage to property if you do not observe this chapter and the safety instructions in this documentation.

- ▶ Read these instructions completely and thoroughly before working with the SY(H)DFED control system.
- ▶ Keep this documentation in a location where it is accessible to all users at all times.
- ▶ Always include the required documentation when you pass the product on to third parties.

2.2 INTENDED USE

The product is electrical/hydraulic equipment.

You may use the product as follows:

- for the electrohydraulic pressure and swivel angle control of an axial piston variable displacement pump

The pressure/flow control system is intended exclusively for being integrated in a machine or installation or for being assembled with other components to form a machine or system. The product may be commissioned only if it is integrated in the machine/system for which it is designed.

Observe the technical data, operating conditions and performance limits according to the data sheet and the order confirmation.

The product is intended exclusively for professional use and not for private usage.

Operation according to the intended use also implies that you have read and understood this documentation completely, especially chapter 2 "Safety instructions".

2.3 IMPROPER USE

Any use other than described in the section "Intended use" is considered as improper and is therefore not permitted.

The installation or use of inappropriate products in safety-relevant applications could result in unintended operating states in the application which in turn could cause personal injuries and/or damage to property. Therefore, please only use a product for safety-relevant applications if this use is expressly specified and permitted in the documentation of the product. For example, in explosion-protection areas or in safety-related parts of a control (functional safety).

Bosch Rexroth AG does not assume any liability for damage caused by improper use. The user assumes all risks involved with improper use.

Improper use of the product includes:

- If you do not adhere to the technical data, operating conditions and performance limits specified in the data sheet and given in the order confirmation.
- If you do not observe national EMC regulations during operation for the application at hand. The manufacturer of the system or machine is responsible for complying with the limit values stipulated in national regulations (European countries: EU Directive 2014/30/EU (EMC Directive); USA: See National

Electrical Code (NEC), National Electrical Manufacturers Association (NEMA) as well as regional engineering regulations.

- If you use the SY(H)DFED control system in a potentially explosive atmosphere.

2.4 QUALIFICATION OF PERSONNEL

The activities described in this documentation require basic knowledge of mechanics, electrics and hydraulics as well as knowledge of the appropriate technical terms. In order to ensure safe use, these activities may only be carried out by an expert in the respective field or an instructed person under the direction and supervision of an expert.

Experts are those who are able to recognize potential hazards and apply the appropriate safety measures due to their professional training, knowledge and experience, as well as their understanding of the relevant requirements pertaining to the work to be undertaken. An expert must observe the relevant specific professional rules and have the necessary expert knowledge.

Expert knowledge means for example for hydraulic products:

- Reading and completely understanding hydraulic circuit diagrams,
- in particular, completely understanding the correlations regarding safety equipment and
- knowledge of the function and structure of hydraulic components.



Bosch Rexroth offers training courses that support your qualification in specific fields. You can find an overview of training contents on the Internet at: <http://www.boschrexroth.com>

2.5 GENERAL SAFETY INSTRUCTIONS

- Observe the valid regulations on accident prevention and environmental protection.
- Observe the safety regulations and provisions of the country in which the product is used/applied.
- Exclusively use Rexroth products in technically perfect condition.
- Observe all notices on the product.
- Persons who install, commission, operate, demount or maintain Rexroth products must not consume any alcohol, drugs or pharmaceuticals that may affect their ability to respond.
- Only use accessory and spare parts released by the manufacturer in order to rule out personnel hazards arising from unsuitable spare parts.
- Comply with the technical data and ambient conditions specified in the product documentation.
- If unsuitable products are installed or used in safety-relevant applications, unintended operational states can occur in these applications, which can cause personal injury and damage to property. Therefore, use the product only in safety-relevant applications, if this use is expressly specified and permitted in the documentation of the product.
- You may commission the product only when it has been established that the final product (for example, a machine or system), in which the Rexroth product is installed, complies with national regulations, safety regulations and standards relevant for the application.

2.6 PRODUCT- AND TECHNOLOGY-RELATED SAFETY INSTRUCTIONS

WARNING

Control system falling down!

SY(H)DFED control systems are heavy. When improperly handled, they can fall down and cause severe injuries and crushing, because the parts can be, for example, sharp-edged, heavy, oily, loose or bulky.

- ▶ Transport the SY(H)DFED control system using suitable lifting gear at the points provided for this purpose.
- ▶ Ensure a stable position while transporting the control system to the place of installation.
- ▶ Wear personal protective equipment when transporting the control system.
- ▶ Comply with the national laws and regulations regarding occupational health and safety for transporting/handling.

Systems not shut down!

Working on running systems poses a danger to life and limb. The work steps described in these operating instructions may only be performed on shut down systems. Before beginning work:

- ▶ Make sure that the drive motor cannot be switched on.
- ▶ Make sure that all power-transmitting components and connections (electrical, pneumatic, hydraulic) are switched off according to the manufacturer's instructions and are secured against being switched on again. If possible, remove the main fuse of the system.
- ▶ Ensure that the system is completely hydraulically unloaded and depressurized. Please follow the system manufacturer's instructions.
- ▶ Only qualified personnel (see chapter 2.4 "Qualification of personnel" on page 11) are authorized to install the SY(H)DFED control system.

Lines under pressure!

Risk of injury.

- ▶ Never disconnect, open or cut pressurized lines!
- ▶ Before carrying out any installation or other work, depressurize the control system.

High electrical voltage!

Danger to life and risk of injury due to electric shock.

- ▶ Before starting installation work, plugging and unplugging connectors and carrying out any work, switch the control system off. Secure the electrical equipment against restarting.
- ▶ Before switching the control system on, check the protective conductor on all electrical devices for proper connection according to the wiring diagram.

 **WARNING****High noise emission during operation!**

The noise emission of SY(H)DFED control systems depends, among others, on speed, operating pressure and the installation situation. Under normal operating conditions, the noise pressure level may rise above 70 dB(A). This can cause hearing damage.

- ▶ Always wear hearing protection when you work in the vicinity of a running SY(H)DFED control system.

Hot surfaces!

Risk of burning.

The SY(H)DFED control system heats up considerably during operation. The pilot valve of the SY(H)DFED control system gets so hot during operation that you may burn yourself.

- ▶ Let the SY(H)DFED control system cool down before touching it.
- ▶ Protect yourself by wearing heat-resistant protective clothing, e.g. gloves.

Health-damaging hydraulic fluid!

Contact with hydraulic fluids can be damaging to your health (e.g. eye injuries, skin damage, intoxication upon inhalation and swallowing).

- ▶ Always check the lines for wear and damage before each commissioning.
- ▶ When doing so, wear protective gloves, safety goggles and suitable working clothes.
- ▶ If nevertheless hydraulic fluid comes into contact with the eyes or penetrates the skin, please consult a doctor immediately.
- ▶ When handling hydraulic fluids, strictly observe the safety notes of the hydraulic fluid manufacturer.

Easily inflammable hydraulic fluid!

Risk of fire.

- ▶ Keep open fire and sources of ignition away from the SY(H)DFED control system.
- ▶ Ensure sufficient ventilation.

 **CAUTION****Improperly laid lines and cables!**

Risk of stumbling!

- ▶ Lay cables and lines so that no one can stumble over them.

Uncontrolled system behavior!

The failure of individual components can lead to malfunction of the assembly and therefore to unforeseeable behavior!

- ▶ Replace or have defective components replaced immediately.

2.7 PERSONAL PROTECTIVE EQUIPMENT

Personal protective equipment for users of the product consists of:

- Protective gloves and safety shoes for transporting the SY(H)DFED control system.
- Hearing protection for working in the direct vicinity of the running system.

All components of personal protective equipment must be intact.

2.8 OBLIGATIONS OF THE MACHINE END-USER

The operation of installations, systems and machines basically requires the implementation of a holistic IT security concept which is state-of-the-art in terms of technology. Accordingly, Bosch Rexroth products and their properties must be considered as components of installations, systems and machines for their holistic IT security concept.

Unless otherwise documented, Bosch Rexroth products are designed for operation in local, physically and logically secured networks with access restrictions for authorized persons, and they are not classified according to IEC 62443-4-2.

www.summy.it

3 General notes on damage to property and damage to the product

NOTICE

Inadmissible mechanical load!

Hitting or impulsive forces on the drive shaft or the pilot valve can damage or even destroy the SY(H)DFED control system.

- ▶ Do not hit the coupling or drive shaft of the axial piston unit.
- ▶ Do not set/place the axial piston unit on the drive shaft or the pilot valve.
- ▶ Never use the SY(H)DFED control system as a handle or step. Do not place/put any objects on top of it.

Foreign bodies and contaminants in the control system!

Risk of damage, wear and malfunctions due to ingress of dirt and foreign particles.

- ▶ During installation, ensure utmost cleanliness in order to prevent foreign particles such as welding beads or metal chips from getting into the hydraulic lines.
- ▶ Before commissioning, make sure that all hydraulic connections are tight and that all seals and closing elements of plug-in connections are correctly installed and not damaged.
- ▶ Take care that no cleaning agents enter the hydraulic system.
- ▶ Do not use cotton waste or lint cloths for cleaning.

Wear!

Wear may lead to malfunctions.

- ▶ Carry out the prescribed maintenance work at the time intervals specified in the operating instructions.

Environmentally harmful hydraulic fluid!

Leaking hydraulic fluid leads to environmental pollution.

- ▶ Immediately remedy any leakage.
- ▶ Dispose of the hydraulic fluid in accordance with the national regulations in your country.

Insufficient pressure!

If the pressure falls below the specified value, damage can occur or the product be destroyed.

- ▶ Make sure that the pressure cannot fall under the prescribed minimum value.

Insufficient hydraulic fluid!

If you commission or operate the SY(H)DFED control system without or with insufficient hydraulic fluid, the control system is immediately damaged or even destroyed.

- ▶ When commissioning or re-commissioning a machine or system, make certain that the housing chamber as well as the suction and working lines of the control system are filled with hydraulic fluid and remain filled during operation.

4 Scope of delivery

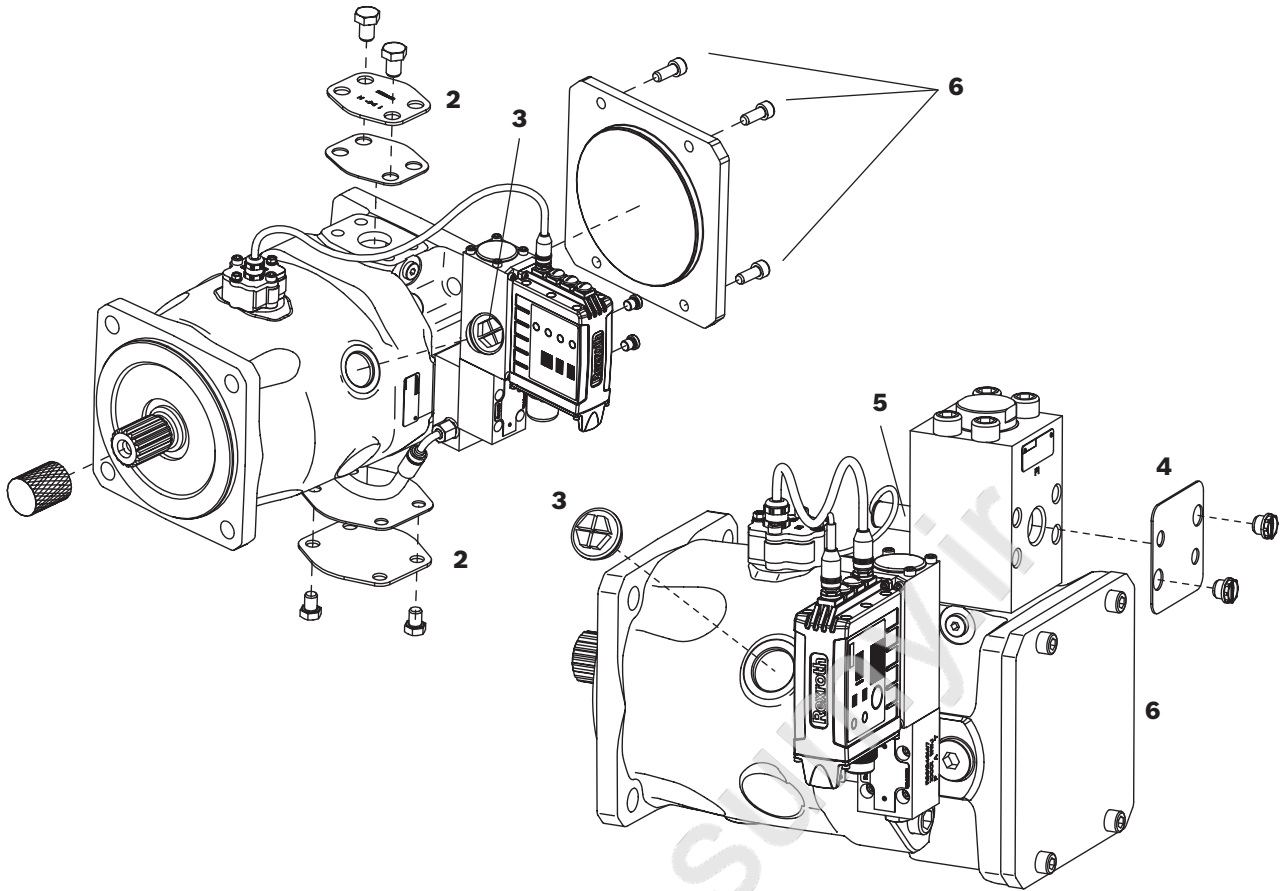

Fig. 1: Control system SYDFED

The following is included in the scope of delivery:

- 1 control system SY(H)DFED

When delivered, the following parts are mounted additionally:

- Transport protection for drive shaft end **(1)** in the case of keyed shaft
- Protective caps **(2, 4)**
- Plastic plugs/plug screws **(3)**
- Pressure transducer (optional) **(5)**
- The connection flange is closed operationally safe with a cover (optionally on variant with through-drive) **(6)**

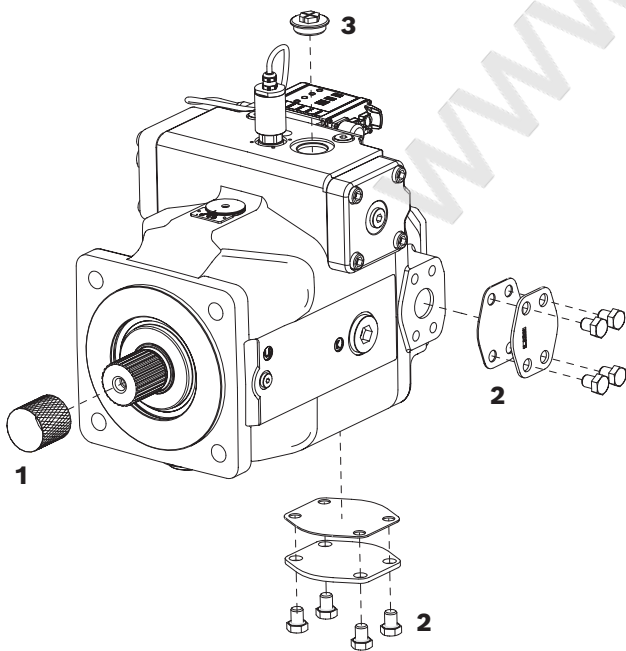

Fig. 2: Control system SYHDFED

5 Product description

5.1 PERFORMANCE DESCRIPTION

The SY(H)DFED control system is designed and built for the electrohydraulic control of swivel angle, pressure and power/torque of an axial piston unit. It is intended for stationary applications.

Please refer to the data sheet and order confirmation for the technical data, operating conditions and operating limits of the SY(H)DFED control system.

5.2 DEVICE DESCRIPTION

The SY(H)DFED control system is based on an axial piston variable displacement pump of swashplate design for hydrostatic drives in the open circuit. The flow is proportional to drive speed and displacement. The flow can be steplessly varied by adjusting the swashplate.

Open circuit

In an open circuit, the hydraulic fluid flows from the tank to the variable displacement pump and is transported from there to the consumer via a directional valve. From the consumer, the hydraulic fluid flows via the directional valve back to the tank.

In the regenerative operating mode (see chapter 5.3.4.1 “Regenerative operation“ on page 24) the hydraulic fluid can also flow from the consumer through the pump to the tank.

Variable-speed operation

For the control system SY(H)DFED we offer the order option “variable-speed operation”. Variable speed operation is an additional function, which determines the optimum drive speed for the motor in dependence on the current working point and passes it on to the drive. In addition, this additional function allows power losses to be reduced.

5.2.1 Functional description, section of SY(H)DFED

The numbers in the description below refer to the numbers in brackets in Fig. 3, 4 and 5 on pages 19 and 20.

The pressure and swivel angle of the A10VSO variable displacement pump of the SY(H)DFED control system is controlled using an electrically operated proportional valve **(2)**. The proportional valve determines the position of the swashplate **(1)** by means of the actuating piston **(4)**. The displaced flow is proportional to the position of the swashplate. The counter-piston **(3)**, which is preloaded by a spring **(5)**, is permanently pressurized to pump pressure.

While the pump is not rotating and the actuating system is depressurized, spring **(5)** holds the swashplate in position +100 %. With a driven pump and a de-energized proportional solenoid **(8)** the system swivels to zero stroke pressure as the valve spool **(9)** is pushed to the initial position by the spring **(10)** and, therefore, pump pressure p is applied to the actuating piston **(4)** via valve port “A”. A balance between the pump pressure on the actuating piston and the spring force **(5)** is achieved at a pressure of 8 to 12 bar. This basic position (= zero stroke operation) is obtained e.g. when the valve electronics is de-energized.



In contrast to this, a pump with external supply swivels to the negative limit stop (regenerative operation). See also section 5.3.4.1 “Regenerative operation“ on page 24.

The proportional valve is controlled by digital electronics (**11**), which is integrated in the valve. This closed-loop control electronics processes all of the control signals required to operate the A10VSO respectively A4VSO variable displacement pump under closed-loop pressure and flow control.

The control electronics receives its command values for pressure, swivel angle and torque limit over the field bus systems (for the selection, see order option 13 in the type code) (**14**). Alternatively, the command values for pressure and swivel angle can be provided via one analog input each. A pressure transducer can be connected to the central plug (**12**). Alternatively, an HM20 pressure transducer can be connected to port P of the pump or, if a SYDZ preload valve is used, installed in port MP1 and connected to X2M1.

A position transducer with integrated electronics (**7**) fitted to the pump establishes the actual swivel angle value. The acquired actual values are processed in the amplifier and compared with the given command values. A minimum value comparator ensures that automatically only the controller assigned to the desired working point is active. Thereby, a system variable (pressure, swivel angle or torque) is exactly corrected, the other two variables are below the specified command values. The output signal of the minimum value comparator becomes the command value for the valve control loop.

The actual value of the valve spool position is sensed using an inductive position transducer (**6**). The output value of the valve position controller determines via the amplifier output stage the current through the proportional solenoid (**8**). As soon as the working point is reached the control spool (**9**) of the proportional valve is held in the centered position.

When the higher-level controllers demand an increase in the swivel angle (increase in flow), the valve spool (**9**) must be moved away from the central position (connection of the actuating piston (**4**) A → T) until the swivel angle has reached the required value. The movement of the valve spool against the force of the spring (**10**) is achieved by a corresponding increase in the electrical current through the proportional solenoid (**8**).

A reduction of the swivel angle (reduction in flow) is achieved by connecting the actuating piston (**4**) from P → A.

The actuating system of the pump can be supplied with pilot oil in three different ways:

1. Internal, without pre-load valve (only possible for operating pressures >20 bar)
2. Internally, with pre-load valve (operating pressure 0...100 %)
3. External supply via a shuttle valve - automatic switching between internal/external via a shuttle valve sandwich plate! (See chapter 5.3.6 "Internal/external pilot oil" on page 27).

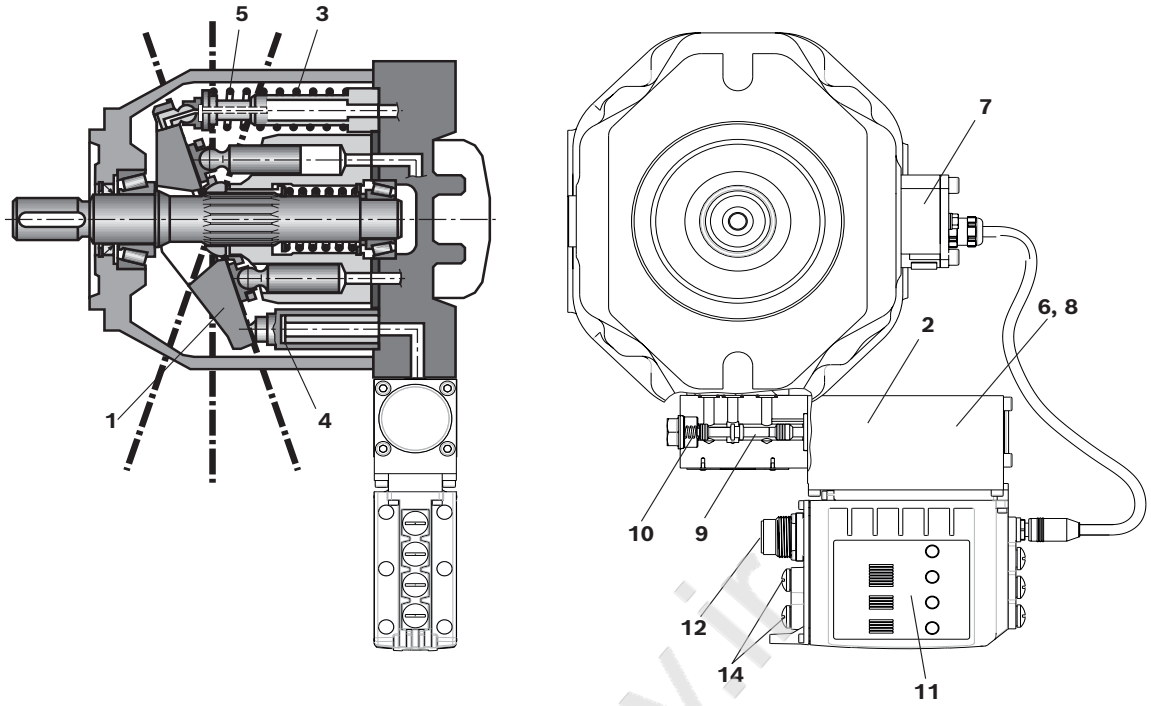

Fig. 3: Sectional drawing of SYDFED, series 2X

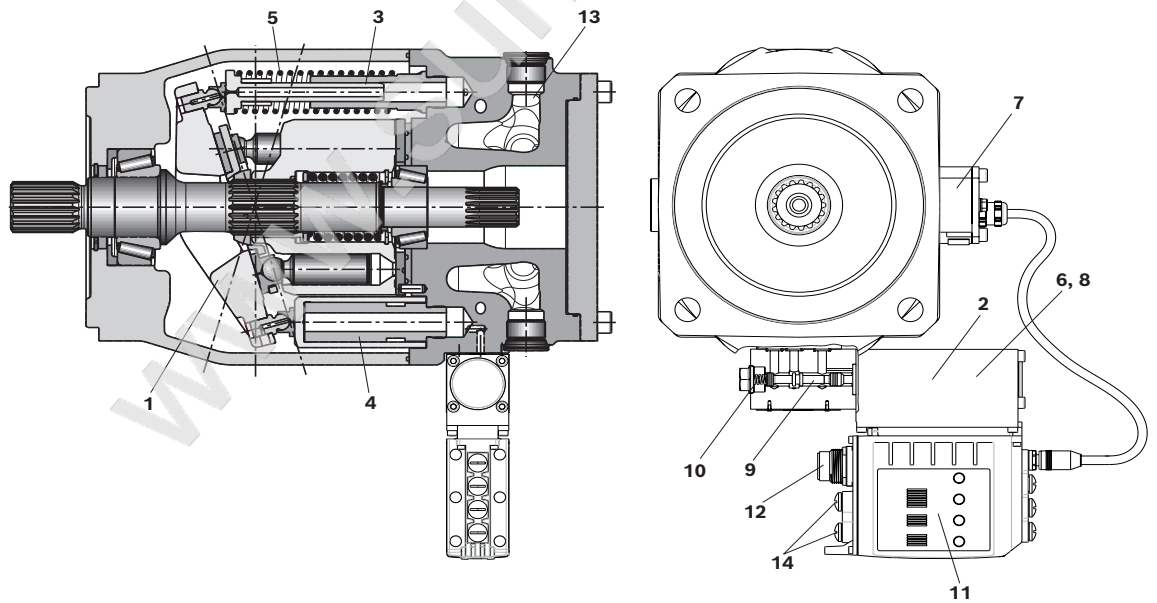

Fig. 4: Sectional drawing of SYDFED, series 3X

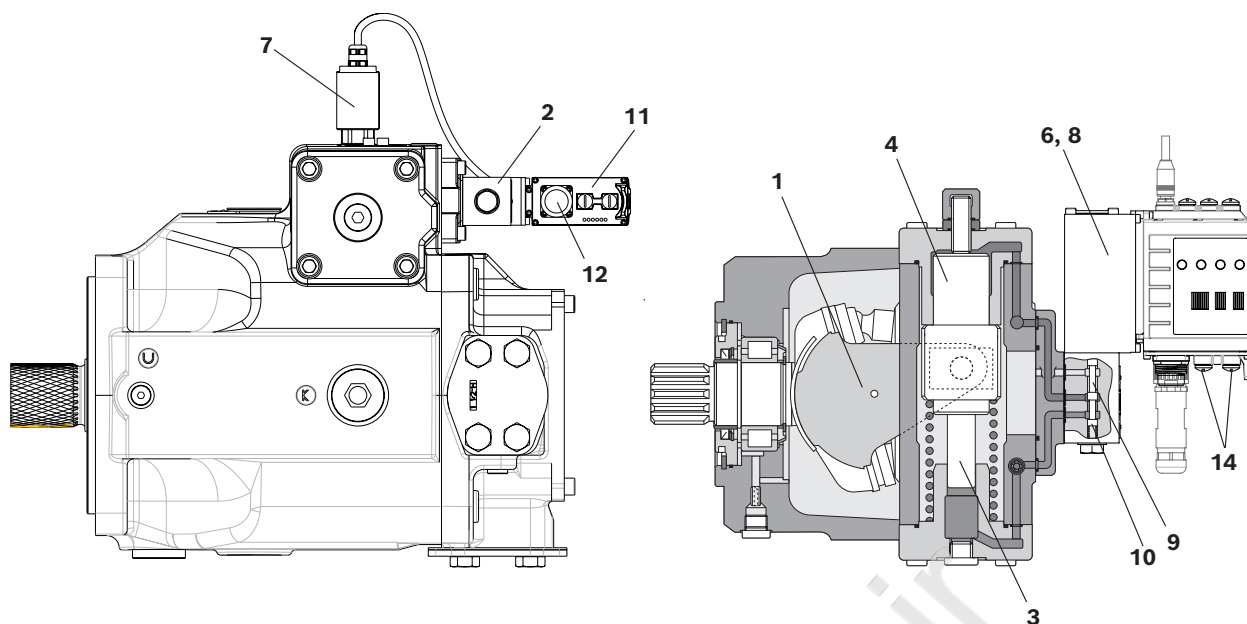

Fig. 5: Section of SYHDFED, series 1X

- | | |
|---|--|
| 1 Swashplate | 2 Proportional valve VT-DPFD |
| 3 Counter-piston | 4 Actuating piston |
| 5 Spring | 6 Inductive position transducer |
| 7 Swivel angle position transducer | 8 Proportional solenoid |
| 9 Proportional valve spool | 10 Spring |
| 11 Digital electronics | 12 Central connector |
| 13 Pre-compression volume PCV | 14 Multi-Ethernet interface |

The sectional drawings above show the mechanical basic position “+100 %” of the pump (depressurized, drive at rest). This corresponds to the maximum swivel angle of the pump.

Zero stroke pressure: Pressure, which the pump with internal supply generates for its own supply without activation of the pilot valve. The pressure level is usually within the range of 8 to 12 bar. This pressure level can only be achieved when the maximum oil flow, which the pump can deliver, is not exceeded. The pump with **internal supply** automatically swivels in to zero stroke operation after the electric drive was started and when the control electronics is de-energized, provided that the required pilot pressure can build up (consumer line is closed).

In contrast to this, the pump with **external supply** swivels in to the **negative limit stop “-100 %”**!

NOTICE! Cavitation of the pump!

Risk of damage to the pump in the case of systems with external supply.

- ▶ To prevent damage to the pump, provide a pressure relief/anti-cavitation valve for systems with external supply. If a fault occurs during operation - not during start-up - the motor must be switched off.

5.3 CONTROL OF THE SY(H)DFED CONTROL SYSTEM

Basic operating modes Up to two controllers are continuously active in the possible operating modes:

- Swivel angle controller or flow controller
- Pressure controller

These controllers alternate automatically and jerk-free through the changeover logic.

The controller, the actual value of which comes closest to the command value, takes over control.

In general, for the transition of a system from a given initial state to a given final state, a fast transition and steady state are envisaged. To meet this requirement, various control algorithms are used in closed-loop control technology.

The digital SY(H)DFED control is provided with 4 controller parameter sets for optimum adjustment to system-specific requirements. For this purpose, up to 4 instances of the parameters relevant for controlling are created in the HydraulicDrive after the relevant controller parameter set was activated. The setting of the individual controller parameters depends on the control properties of the entire system. The following factors must be taken into account for this:

- Hydraulic structure of the system (e.g. piping, branches)
- Connected oil volume
- Current drive speed



For a detailed description of the additional function “variable-speed operation”, please refer to the supplementary description RE 30237-Z. This document also contains commissioning notes on variable-speed operation.

5.3.1 Structure of the control

The following control structure is used in the HydraulicDrive:

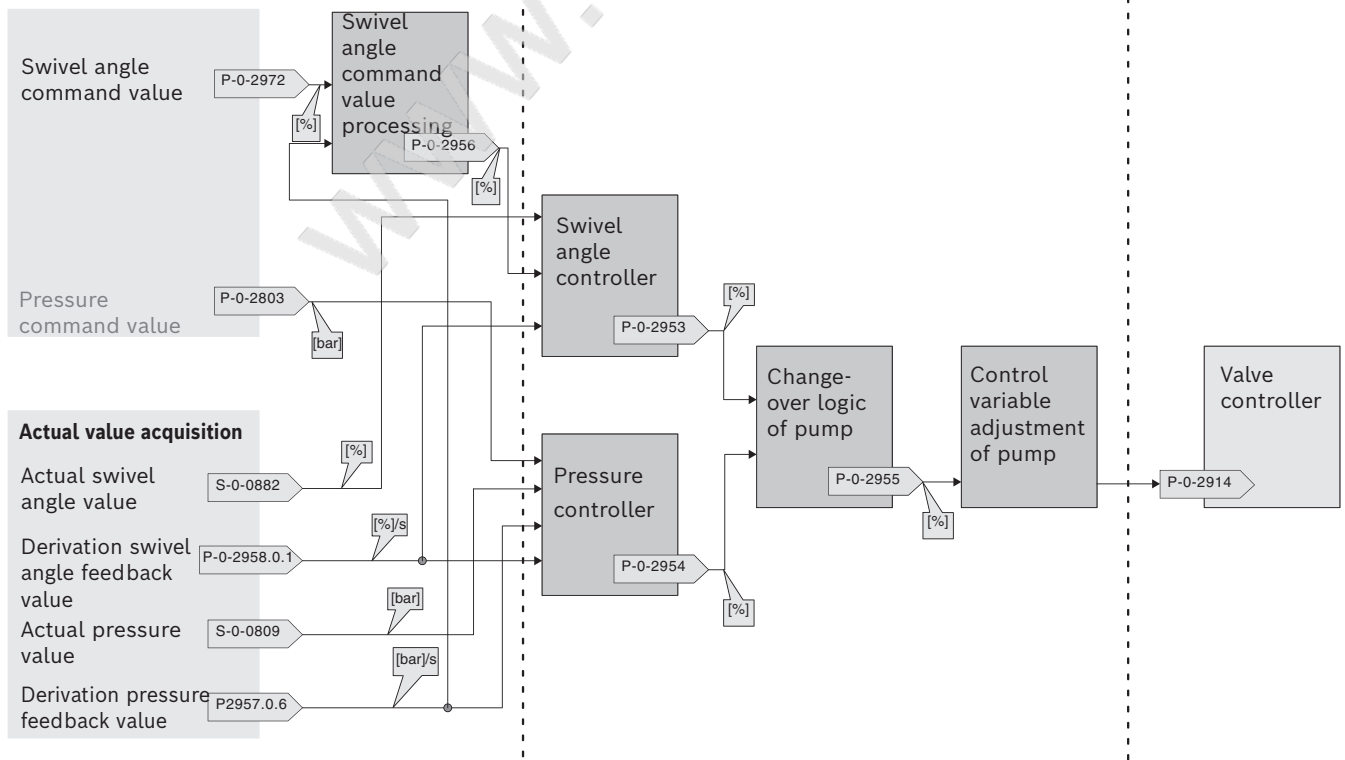

Fig. 6: Overview of controllers in parallel structure

The parallel structure with pressure controller and swivel angle controller is called in the operating mode “pressure/swivel angle control” or “pressure/flow control”.

The swivel angle command value is adjusted in swivel angle command value processing before it is passed on to the actual swivel angle controller.

In pump control the pressure and the swivel angle controller are simultaneously active and both generate an actuating value. In standard cases, the changeover logic of the pump passes on the smallest control variable of both controllers (minimum value comparator function). This minimum value comparator ensures that always only one of the two variables of pressure or swivel angle is used for controlling and that it is possible to switch dynamically between the two control types. The output variable of the pump changeover logic can be modified using various characteristic curves and functions in output adjustment of the pump before the variable is handed over to the valve controller as valve command value.

5.3.2 Controller parameters

The following controller parameters are involved in pressure and swivel angle control:

Table 6: Controller parameters

| Description of the controller parameter | Parameter number |
|--|------------------|
| Pressure controller P-gain 1 positive | P-0-2963 |
| Pressure controller P-gain 1 negative | P-0-2964 |
| Pressure controller pos. factor for D-component, parallel | P-0-2969 |
| Pressure controller neg. factor for D-component, parallel | P-0-2970 |
| Pressure controller time constant swivel angle feedback | P-0-2971 |
| Gate time derivation actual pressure value 1 | P-0-2960 |
| Gate time derivation actual pressure value 2 | P-0-2979 |
| Swivel angle controller P-gain | P-0-2977 |
| Swivel angle controller time constant D-component | P-0-2978 |
| Time constant for feedback of actual pressure value derivative | P-0-2974 |
| Filter time for feedback of actual pressure value derivative | P-0-2973 |

After the extended pressure controller with inflected characteristic curve was activated, the following controller parameters are active additionally:

Table 7: Controller parameters

| Description of the controller parameter | Parameter number |
|--|------------------|
| Pressure controller P-gain 2 positive | P-0-2965 |
| Pressure controller P-gain 2 negative | P-0-2966 |
| Pressure controller control deviation threshold positive | P-0-2967 |
| Pressure controller control deviation threshold negative | P-0-2968 |

5.3.3 Controller parameter sets

The SY(H)DFED control system offers the possibility of configuring and using up to four different parameter sets. With the help of these parameter sets the control behavior of the SY(H)DFED control system can be optimized to suit different connected oil volumes. The following table lists various settings as guideline for the controller parameters in conjunction with different oil volumes:

Table 8: Controller parameters for different oil volumes

| Controller parameters | Oil volume [l] | Universal (default setting) | 0 l | 1 l | 2.5 l | 5 l | 7.5 l | 10 l |
|--|----------------|-----------------------------|---------|---------|---------|---------|---------|---------|
| Pressure controller P-gain 1 positive (P-0-2963) | | 2.8 | 2.8 | 4.3 | 4.3 | 4.7 | 5 | 4.3 |
| Pressure controller P-gain 1 negative (P-0-2964) | | 2.8 | 2.8 | 4.3 | 4.3 | 4.7 | 5 | 4.3 |
| Pressure controller pos. factor for D-component, parallel (P-0-2969) | | 0.19 s | 0.04 s | 0.2 s | 0.31 s | 0.41 s | 0.44 s | 0.45 s |
| Pressure controller neg. factor for D-component, parallel (P-0-2970) | | 0.23 s | 0.04 s | 0.2 s | 0.31 s | 0.41 s | 0.44 s | 0.45 s |
| Pressure controller time constant swivel angle feedback (P-0-2971) | | 0.07 s | 0.04 s | 0.07 s | 0.07 s | 0.075 s | 0.05 s | 0.06 s |
| Gate time derivation actual pressure value 1 (P-0-2960) | | 22.5 ms | 13.5 ms | 13.5 ms | 22.5 ms | 22.5 ms | 22.5 ms | 22.5 ms |

| Controller parameters | Oil volume [l] | 12.5 l | 15 l | 20 l | 25 l | 30 l | 40 l |
|--|----------------|---------|---------|---------|---------|---------|---------|
| Pressure controller P-gain 1 positive (P-0-2963) | | 4.4 | 4.4 | 3.8 | 3.6 | 3.6 | 3.5 |
| Pressure controller P-gain 1 negative (P-0-2964) | | 4.4 | 4.4 | 3.8 | 3.6 | 3.6 | 3.5 |
| Pressure controller pos. factor for D-component, parallel (P-0-2969) | | 0.52 s | 0.535 s | 0.59 s | 0.68 s | 0.7 s | 0.72 s |
| Pressure controller neg. factor for D-component, parallel (P-0-2970) | | 0.52 s | 0.535 s | 0.59 s | 0.68 s | 0.7 s | 0.72 s |
| Pressure controller time constant swivel angle feedback (P-0-2971) | | 0.07 s | 0.07 s | 0.07 s | 0.07 s | 0.07 s | 0.07 s |
| Gate time derivation actual pressure value 1 (P-0-2960) | | 22.5 ms | 22.5 ms | 22.5 ms | 22.5 ms | 22.5 ms | 22.5 ms |



When the drive speed is changed, the pressure controller has to be adjusted as well. For further information on this adjustment, see RE 30237-Z.

5.3.4 Special operating modes

This chapter describes certain applications. In these cases, the basic operating modes (see page 21) are active.

Starting up at zero pressure

For starting up SY(H)DFED systems, no hydraulic circuit needs to be provided for the classical start-up at zero pressure.

When small command values for pressure and swivel angle are provided, starting up under almost no-load conditions is possible.

Circulation operation (by-pass filtration, cooling)

In the case of systems with internal supply and without pre-load valve, hydraulic circulation circuits must be dimensioned so that a minimum pressure of between 8 and 12 bar is available, because the pump requires this pressure level to be able to respond to electrical control signals.

Stand-by operation

Operating mode of the pump, in which an operating point is steadily closed-loop-controlled with a corresponding command value over a longer period of time. Observe the notes on permissible pressures in chapter 5.3.6 "Internal/external pilot oil" (page 27).

Zero stroke operation

Operating mode of the pump that refers to the smallest achievable swivel angle and to which the pump usually changes over when no closed-loop control is active.

Zero stroke operation can be definitely achieved only by means of a minimum command value feedforward in the closed swivel angle control loop.

The feedforward of “0 bar” via the pressure command value branch is not permitted. This is valid for both, actuating systems with internal and external supply.

The following is valid when the valve electronics is de-energized:

- Zero stroke operation for the internally supplied pump
- Swiveling out to “-100%” of the externally supplied pump

5.3.4.1 Regenerative operation

Regenerative operation is a special operating mode of the SY(H)DFED control system, since in this case the SY(H)DFED control system is operated as both, generator and motor.

Continuous regenerative operation

We can distinguish between continuous regenerative operation and brief regenerative operation. In the first case, by this we understand coupling of the variable displacement pump with a fixed displacement pump. Here, the two pump displacements are fed together to a common consumer.

This operating mode can be utilized in conjunction with a fixed displacement pump in order to increase the displacement. To achieve “zero” displacement, the closed-loop-controlled pump must “take over” the entire flow from the fixed displacement pump and therefore swivels to the negative swivel angle range (motor operation). It must be noted here that both pump sizes must be matched to each other so that the controlled pump (in regenerative operation) must swivel in to max. -70 %. The fixed displacement pump should be mounted to a through-drive of the SY(H)DFED control system.

The following pump variants are available for continuous regenerative operation:

0487: Continuous regenerative operation with external supply

0541: Continuous regenerative operation without external supply (for SYDFED-3X only)



The operating mode “regenerative operation with external supply” is somewhat complicated in terms of design and commissioning, because a pump swiveling in too far (e.g. -75 % instead of -70 %) causes cavitation.

We therefore recommend master/slave operation as an alternative with two closed-loop controlled SY(H)DFED control systems or a pump variant designed for continuous regenerative operation without external supply (SO 0541 in the case of SYDFEx-3X).

Continuous operation is possible when the given operating limits are adhered to. However, at a total displacement of “zero” (that is, at a negative swivel angle of the SY(H)DFED pump) and at high pressures, the noise level increases and efficiency deteriorates.



For working points with a negative swivel angle of the control pump, continuous regenerative operation features a poorer overall efficiency than a comparable master/slave pump system or a comparable single pump. In the case of an energy-saving machine, continuous regenerative operation would reduce the energy-saving effect. A comparable master/slave pump system or a comparable single pump would provide higher energy savings in such an application.

For pumps with external supply, the use of a pressure relief and anti-cavitation valve as shown below in Fig. 7 is indispensable to prevent the pump’s running dry.

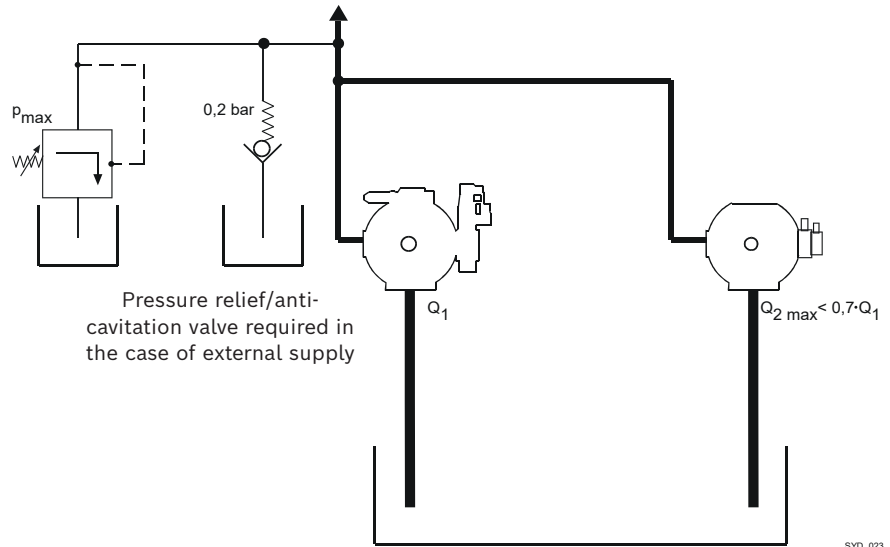

Fig. 7: Circuit diagram for continuous regenerative operation

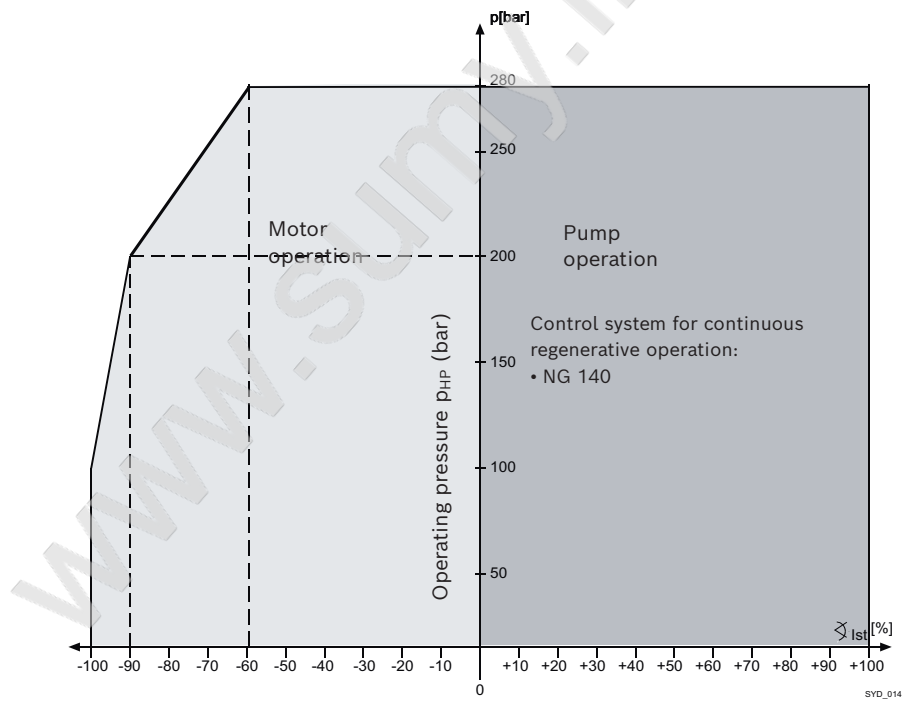

Fig. 8: Operating limits for continuous regenerative operation for series SYDFED-2X and SYDFED-3X for special rotary groups

Brief regenerative operation

During brief regenerative operation the variable displacement pump changes over to motor operation for a limited period of time, e.g. for pressure unloading or for lowering a load. If the requirement profile remains within the limits according to Fig. 9, the standard version of the pump with standard rotary group 0000 or 0479 can be used.

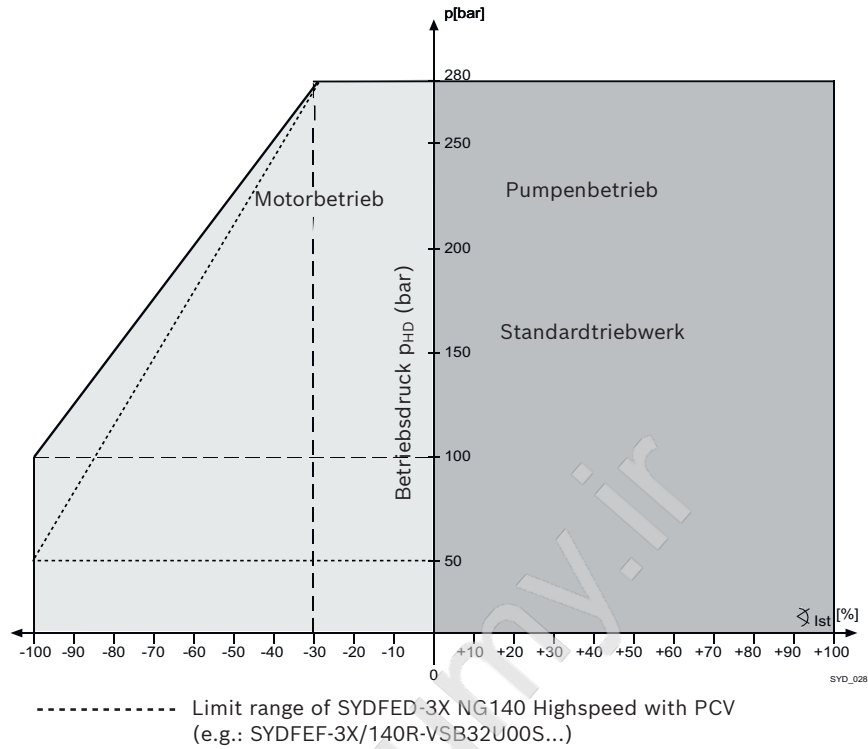

Fig. 9: Operating limits for continuous regenerative operation for series SYDFED-2X and SYDFED-3X for standard rotary groups

Regenerative operation for SYHDFED-1X

With series SYHDFED-1X we do not differentiate between brief and continuous regenerative operation. The operating limits are shown in Fig. 10. Otherwise observe the notes given on continuous regenerative operation and brief regenerative operation on the previous pages.

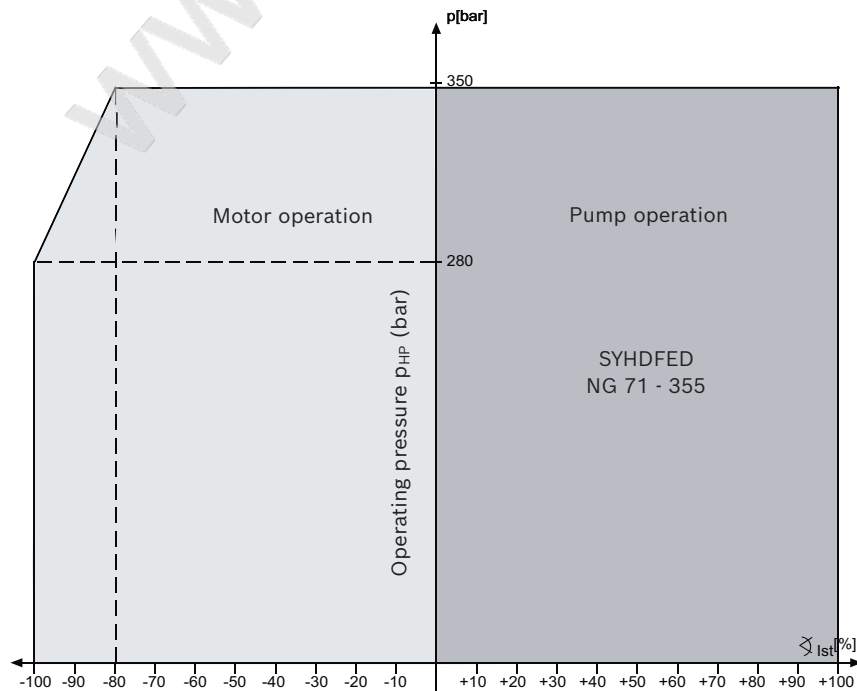

Fig. 10: Operating limits for SYHDFED

5.3.5 Operating pressure limits

WARNING

Forcefully ejected parts and hydraulic fluid jet!

Risk of severe injury! The electrical pressure control does not assume a pressure relief function.

- ▶ Make certain that the maximum operating pressure is not exceeded.
- ▶ If a pre-load valve is installed, you can use its pressure relief function. If no pre-load valve is installed, provide a pressure relief valve, the pressure setting of which is 10 % (recommended) higher than the operating pressure, in the pressure line. Operating the system without this valve can lead to malfunction.

Maximum operating pressure

The maximum operating pressure specified in the data sheet must not be exceeded.



At a pressure of ≥ 250 bar the following restrictions must be observed for SYDFED (**not for SYHDFED**):

- The pressure transducer must be located downstream of a pulsation damper or the high-pressure hose.
- When a standard pilot valve spool is used (version "A"), the pressure controller P-gain may have to be reduced. This has an influence on the accuracy and dynamics of the closed pressure control loop.

Minimum operating pressure

The minimum operating pressure depends on the pilot oil supply and is explained in more detail in the following chapter.

5.3.6 Internal/external pilot oil

Internal pilot oil supply

If the operating pressures of the application are always >20 bar, the version with internal pilot oil supply should be selected, because no cavitation due to too small command values can occur with this version.

Operation is also possible at pressures higher than approximately 12 bar, but dynamics is restricted within the range below 20 bar.

This minimum (pilot) pressure level ensures that the pump can respond to the electrical swivel signal at any time. When the consumer line is blocked, the smallest achievable steady-state swivel angle is the zero stroke angle.

For applications, in which lower operating pressures occur or are to be controlled, a pre-load valve (SYDZ for SYDFED) can be used. For this solution, the minimum pressure is ≥ 1 bar

Pre-load valve

The advantage of the pre-load valve is that the pilot oil pressure of the pump cannot fall below the value preset on the pre-load valve and that pressures ≤ 12 bar on the output side can be continuously controlled.

Being equipped with a pre-load valve the pump cannot permanently swivel back over zero, irrespective of electrical actuating signals or any control errors. The smallest achievable swivel angle during steady-state operation therefore is the zero stroke. This is not valid for applications, in which, for example, a suspended load can cause operating pressures ≥ 12 bar. In such cases the pump can also be used in motor operation (for lowering the load). A check valve integrated in the pre-load valve permits, within certain limits, a reversal of the direction of oil flow.



When using pump combinations

- NG45 with 45/28/18 or
- NG28 with 28/18 or
- NG18 with 18

in conjunction with the SYDZ pre-load valve on the main pump, there is a mechanical conflict between port “P1” of the pre-load valve and the swivel angle transducer housing of the built-on rear pump. For this reason, we suggest that the main pump of the above combinations be equipped with an SAE flange plate $\frac{3}{4}$ “ (NG28) or 1“ (NG45) having a height of $h = 45$ mm. The construction height of the pump assembly therefore changes by dimension “h”.

External pilot oil supply

An additionally built-on sandwich plate with shuttle valve automatically switches the pilot oil supply between the internal or external pilot oil source, with always the higher pressure level being selected.

A pump with external pilot oil supply can be recognized by

- the sandwich plate mounted below the pilot valve and
- the hose routed around the pump case.

With external pilot oil supply, the actuating system of the SY(H)DFED pump works independently of the actual high-pressure circuit, thus allowing an adjustment also below an operating pressure of 12 bar within the range of “ ± 100 %” (change in the direction of displacement!).



When the control electronics is deactivated, the pump swivels to position “-100 %” (motor operation) in an uncontrolled manner. This can lead to cavitation and damage to the pump.

For this reason, special features are to be provided such as a pressure relief and anti-cavitation valve as well as swivel angle actual value monitoring.

The pressure relief and anti-cavitation valve diminishes the risk of the pump’s running dry, the effects of which result in a reduction in the pump’s service life.

The actual swivel angle value monitor could, for example, switch off the entire drive or selectively shut off the pilot oil flow.

The following is valid for the actuating pressure:

$$\text{Pilot oil pressure} \leq \text{minimum operating pressure} + 30 \text{ bar}$$

Recommendation: Absolute pilot oil pressure ≈ 20 bar



Further notes on the operation with external supply:

- In the case of external supply, the pump does not swivel to zero stroke when the pilot valve is de-energized.
- Command values for pressure and flow must always be greater than 1 bar or 5 %, because there is no exact “zero” pressure or “zero” swivel angle due to drift or inaccurate settings. For this reason, selections equal to zero or only slightly greater can lead to cavitation in the worst case.
- In order to ensure sufficient lubrication for the pump system at all times, the actual pressure value must not be less than 10 bar for longer than 10 minutes!

Notes on dimensioning

At a pilot oil pressure of 20 bar the brief pilot oil requirement during swiveling is ca. 17 l/min, at 50 bar it is ca. 25 l/min. In practice, this amount of pilot oil is needed only, if the operating pressure is less than 20 bar during the entire swiveling process and thus the entire pilot oil demand must be supplied by the external source.

In the steady-state, balanced condition, the pilot oil requirement is less than 1 l/min.

Experience has shown that, depending on the operating pressure and swiveling frequency, the actual pilot oil demand is in the order of 5...15 l/min. In the case of external pilot oil supply, the pump size may be reduced by installing an accumulator.

5.4 AMBIENT CONDITIONS

5.4.1 Oil-immersed applications



Only the SY(H)DFE1 control system is suitable for oil-immersed applications. SY(H)DFEx systems with integrated electronics must not be immersed.

5.4.2 Ambient temperature

The permissible maximum ambient temperature for SY(H)DFED control systems is 60 °C. Strictly observe the data in the valid RE data sheets for SY(H)DFED control systems.



We recommend the installation within a ventilated area with moved ambient air, e.g. in the air flow of an electric motor. This is valid in particular in view of the place of installation of the integrated on-board electronics.

5.5 NOTES ON THE SELECTION OF HYDRAULIC FLUIDS

The SYDFED control system is designed for operation with hydraulic fluids in accordance with DIN 51 524 (HL/HLP). The use of HFC is permitted only for SYHDFED.

- ▶ Adhere to all limits specified in the data sheet regarding temperature, viscosity, cleanliness of the hydraulic fluid.

Operating viscosity We recommend that you select the operating viscosity (at operating temperature) within the following range, which is optimum in terms of efficiency and service life:

- v_{opt} = optimum operating viscosity 16...36 mm²/s

This range is referred to the tank temperature in the open circuit.

Viscosity limits The following values are valid for limiting operating conditions:

- v_{min} = 10 mm²/s
Briefly, at max. permissible case drain oil temperature of 90 °C
- v_{max} = 1000 mm²/s
Briefly, during cold start

Temperature range The temperature of the hydraulic fluids lies between the following values: (cf. selection diagram)

- t_{min} = -20 °C
- t_{max} = 70 °C

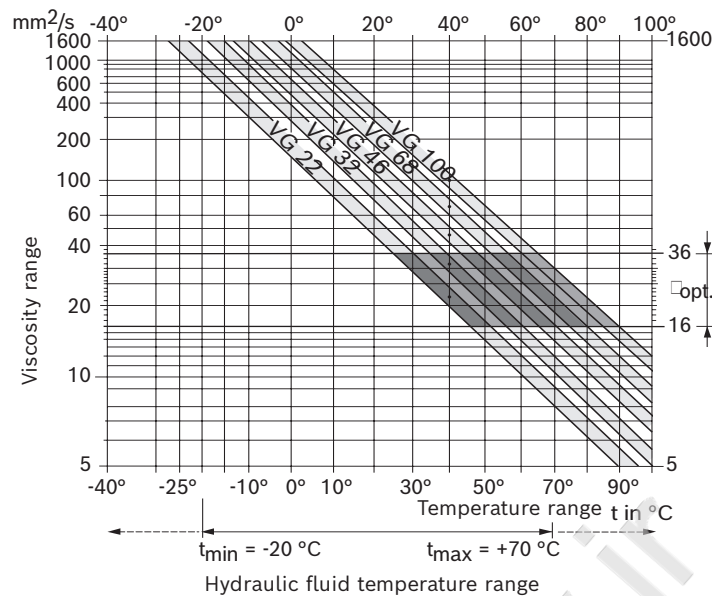

Fig. 11: Selection diagram for the hydraulic fluid

**Notes on the selection:**

In order to be able to select the correct hydraulic fluid, the operating temperature in the tank (open circuit) in relation to the ambient temperature must be known.

The hydraulic fluid should be selected so that within the operating temperature range, the operating viscosity is within the optimal range (v_{opt}). This range is shown as gray area in the selection diagram.

We recommend that you select the next higher viscosity class.

Example:

At an ambient temperature of X °C, the resulting temperature in the tank is 60 °C. Within the optimum operating viscosity range (v_{opt} ; gray area) this corresponds to viscosity classes VG 46 and VG 68. You should select: VG 68.



The case drain oil temperature, which is subject to the influence of pressure and pump revving speed, is always higher than the tank temperature. However, the temperature must not exceed 90 °C at any point in the system.

If the conditions described above cannot be complied with due to extreme operating parameters or high ambient temperatures, please consult us.

Filtration of the hydraulic fluid

The finer the filtration of the hydraulic fluid, the better is the achieved cleanliness class, which, in turn, prolongs the service life of the SY(H)DFED control system.

To ensure functional reliability of the SY(H)DFED control system, the hydraulic fluid must comply at least with cleanliness class 18/16/13 according to ISO 4406 (for particle sizes 4/6/14 μm).

5.5.2.1 HFC fluids

The use of HFC fluids is permitted only for SYHDFED control systems with option "F". For applications with HFC fluids, it must be noted that, due to the reduced lubrication ability of HFC fluids, the service life of the SYHDFED control system is reduced compared with the standard application.

For applications with HFC fluids, the 4-groove spool has to be used for the pilot valve. The spool is specified by "C" in the ordering code of the SYHDFED control system.

For commissioning pump systems that are operated with HFC fluids, please read the relevant commissioning instructions (among others, RE 92053), which are available as separate documents.

5.6 GENERATION OF NOISE

Compared to, for example, vane pumps, axial piston pumps generate greater changes in flows and thus pressure pulsations for design-inherent reasons. Apart from the propagation of air and structure-borne noise, this can have an influence on fluid-borne noise. In the end, these factors together result in the general perception of "noise".

Noise often induces vibration on other components, which, in turn, also generate noise. For example, on check valves possibly used in the system, the integrated springs may have to be adapted to the conditions of the systems, if this is a cause of excitations leading to the generation of noise.

The details given for the noise pressure level in the technical documentation refer to measurements taken in an anechoic chamber. Influences of the surroundings such as place of installation, general mechanical concept, piping, etc., are not taken into account.

5.6.1 Generation of noise in the power unit

"Noise" is composed of various elements. The total "noise" is influenced not only by air-borne noise, but also by structure- and fluid-borne noise.

As a result of unfavorable installation and piping conditions, the noise pressure level of the complete system can be 5 to 10 dB(A) higher than the value of the pump alone.

Noise can be reduced by taking, for example, the following measures:

- Low-noise tank
- Damping ring between pump and pump mounting bracket
- Flexible pipe conduit
- Anti-vibration rails under the motor
- Installation of the pump at a sufficient distance to the tank wall

5.6.2 Pulsation damper

For some special applications, we recommend the use of a pulsation damper. Due to the reduction of typical pump pressure pulsation, this has a positive effect on the noise level of the hydraulic system as a whole.

Further information can be found in data sheet RE 50142.

5.7 SHAFT VARIANT

The SY(H)DFED control system is available with keyed or splined shafts. Compared with the keyed shaft, the splined shaft is not only advantageous with regard to its degrees of freedom during assembly and operation, but also due to its increased torque load carrying capacity and its stability under changing loads.

This is advantageous in particular when pump combinations are to be installed. In the case of multiple pumps, all built-on units are fitted with splined shafts.

In view of the dynamic load carrying capacity and standardization, we recommend the use of standard types with splined shafts. This offers advantages with regard to availability and future spare parts requirements.

When a splined shaft is selected, a clamp coupling must be used for the mechanical connection to the electric motor. Otherwise, frictional corrosion may occur that leads to damage to the pump.

Keyed shaft Due to the advantages of the splined shaft, keyed shafts are not recommended for new applications. The keyed shaft is no longer used for applications with through-drive.

If a single pump is to be used later as “end pump” in a multiple-pump system, a splined shaft must be selected.

Splined shaft Splined shaft profiles depend on the size (NG) of the pump. Two different splined shaft profiles are therefore available in conjunction with SY(H)DFEx:

- “S”-profile for NG18, NG100 and NG140
- “R”-profile for NG28 ... 71

When compared with the “S”-profile, the “R”-profile features further improved properties with regard to the torque carrying capacity of the shaft. This version represents the optimum for a wide variety of applications.

5.8 SPOOL VARIANTS OF PILOT VALVE VT-DFPD-X-1X

The standard spool according to the ordering code is spool type “A” (360° spool). The 4-groove spool of type “C” is also allocated to SYHDFED as standard for applications using HFC media.

5.9 MASTER/SLAVE OPERATION

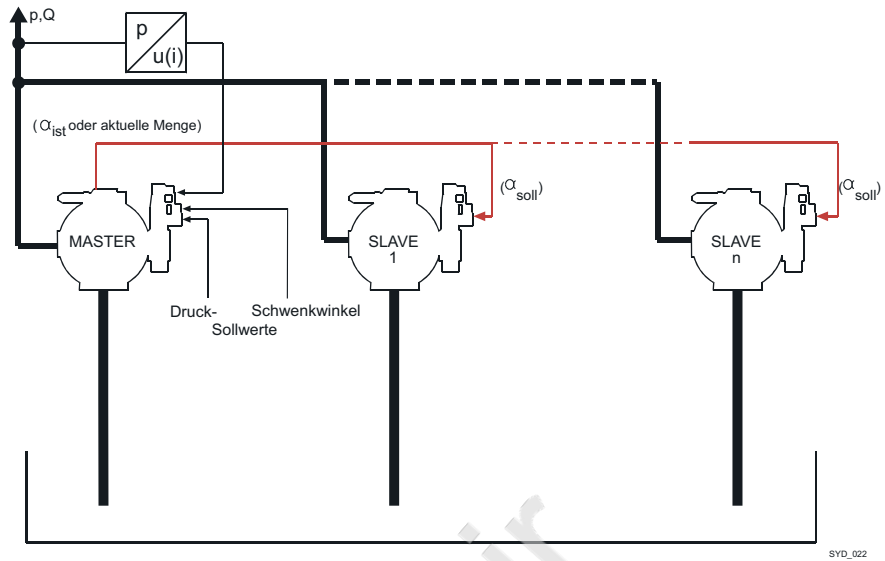

Fig. 12: Hydraulic coupling of SY(H)DFED control systems

Theoretically, an optional number of SY(H)DFED control systems can be hydraulically coupled to achieve greater flows.

In this case, it is just required to determine a master pump to which the pressure transducer has to be connected.

The master then controls both, pressure and swivel angle, in accordance with the externally provided command values and passes its actual swivel angle value on to the slave pumps. Based on this input the slave pumps calculate their own swivel angle command value. This ensures smooth and synchronous swiveling of the pumps.

5.9.1 Circuitry of SY(H)DFED

The two figures below show the circuitry for master/slave operation with analog signals. Alternatively, master/slave operation can also be set up via a field bus system and the machine control. For detailed information, see the functional description of the firmware used.

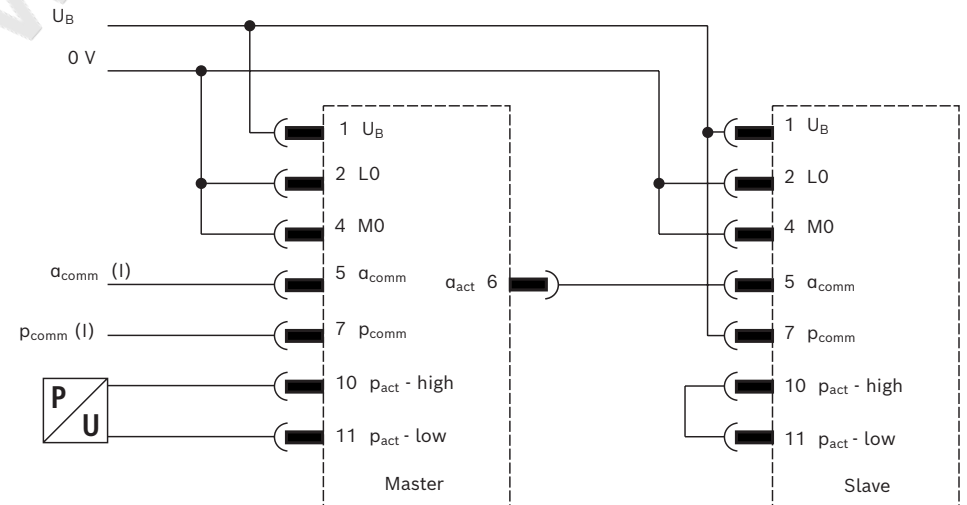

Fig. 13: Circuitry of SY(H)DFED for master/slave operation (analog)

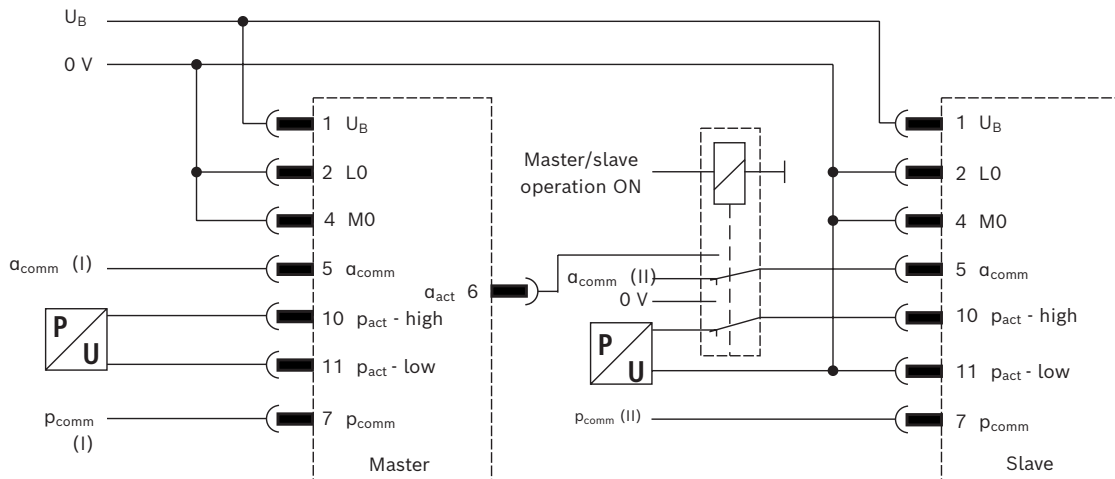

Fig. 14: Circuitry of SY(H)DFED for master/slave operation (analog) and individual operation

**Notes:**

- For the configuration of analog command value provision, see the functional description of HydraulicDrive
- The connection for the position transducer of the pump is not drawn here.
- The coupling element (relay, analog switch) can be optionally installed to control both pumps independently of one another. With the proposal shown here, both, swivel angle and pressure control are possible with the slave pump.
- For the master/slave operating mode, the signal $p_{comm}(II)$ must be set to maximum (+10 V).
- If closed-loop pressure control is to be realized also in the master/slave operating mode, only the pressure transducer of the master is evaluated for controlling purposes. If hydraulically separated operation should be possible, too, a separate pressure transducer is required for the slave.
- If the signal branch of the pressure transducer of the slave axis is not provided with a specific circuitry, its pressure controller could intervene into the swivel angle control in an undesirable manner, when the actual pressure value $p_{act}(II)$ reaches values in the order of ca. 80 % or higher of the command value $p_{comm}(II)$. This can be prevented by connecting a "0 V" signal instead of the pressure transducer output signal to pin 10 via a second channel of coupling element "K1" in the master/slave operating mode. Care must be taken that the P- and D-controller parameter on the slave is not set higher than on the master.

5.9.1.1 Changing over to master/slave operation (analog)**Starting point**

0 V reference potentials of the PLC/command value source and M0/L0 of the SYDFED electronics must be connected.

- ▶ Shortly **before** the changeover takes place, switch both pumps to pressure control (low, identical pressure level), while they are hydraulically still uncoupled from each other. Approximately identical actual swivel angle values would be optimal. The two flow command values (usually 100 %) still are provided by the control.



When a pre-load valve is used, the pump with the pre-load valve should preferably be the master pump.

**Changing over to master/
slave operation**

At low operating pressures, the flow command value, which has been previously provided by the control, is withdrawn from the slave pump via a changeover contact suitable for small signal voltages (or, alternatively, a wear-free analog switch), and the actual swivel angle value provided by the SY(H)DFED electronics of the master pump is fed forward.

The pressure command value of the slave pump is to be set to 100 % (if required, using a second changeover contact or by means of software) in order that closed-loop pressure control of this unit is quasi switched off.

Now, the hydraulic short-circuit valve (connection of the previously separated pressure circuits) can also be activated. The activation of this valve may have to be delayed depending on whether this would improve the system characteristics in the changeover process (the activation would also be conceivable with a hydraulic switching delay).

**Deactivating master/
slave operation**

In the master/slave operating mode it is also useful that the control keeps the two swivel angle command values for the master and the slave pump synchronized in order that striking differences in the signal level are prevented when the swivel angle command value source for the slave pump is switched (from actual swivel angle value of the master pump back to the control output).

The pressure command value of the slave pump should be set to the same level as that of the master pump before the slave pump is changed over to individual operation (jerk-free changeover).

**Connection of unused
electrical signal inputs**

All the analog inputs that are not used, e.g. actual pressure value input in the case of flow control, must be connected to 0 Volt.

In contrast to this, differential amplifier inputs that are not used may also be short-circuited.

5.10 DESCRIPTION OF THE COMMISSIONING TOOL INDRAWORKS

The SY(H)DFED control system can be configured and parameterized in two different ways:

1. Connection to an Ethernet-based field bus system. (For the selection of the possible systems, see type code in the data sheet).
2. Use of the Bosch Rexroth software IndraWorks. For the SY(H)DFED system, IndraWorks version 15V12 or a higher version must be used.

The IndraWorks Ds software is available free of charge on the Rexroth website in the section "SY(H)DFED" under "Download":

<http://www.boschrexroth.com/sydfed>

5.10.1 System requirements

Minimum requirements:

- IBM-compatible PC, at least Pentium IV
- CPU clock frequency 2 GHz
- RAM: 4 GB
- 5 GB free hard disk space on drive C: (incl. temporary memory for installation)
- DVD drive (if to be installed from DVD)
- Graphics resolution:
 - 800x600 pixels
 - Color depth 16 bits



IndraWorks Engineering is designed for a screen setting of 96 dpi (default setting). The use of other settings may result in the fact that screen elements are displayed incompletely or incorrectly.

Recommended preconditions

- IBM-compatible PC, i5 Quad Core
- RAM: 4 GB with 64-bit operating systems

Supported operating systems

- Microsoft Windows 10

5.10.2 Firmware update

CAUTION

Uncontrolled movements of the drive!

Risk of injury! All data in the control are overwritten and a software reset is executed on the control.

- ▶ Switch the drive motor off! A software reset corresponds to a power-on reset of the control and may only be carried out when the system is in a safe condition.

Current firmware is made available by Rexroth together with the project files. New firmware can be transmitted to the control under menu item “Service” → “Firmware Administration”.

Current firmware projects can also be downloaded from the Rexroth website in the section “SYDFED” under “Download”:

<http://www.boschrexroth.com/sydfed>

5.11 SWITCH-ON SEQUENCE OF ELECTRONICS/HYDRAULICS

Due to various monitoring routines implemented in the electronic assemblies, fault messages may be generated in the case of an unfavorable order of switching on. These error messages cause uncertainties, although they have no “real” cause of fault.

In principle, it is valid that all SY(H)DFED control systems that are provided with internal pilot oil supply automatically swivel to the operationally safe zero stroke position in the event of a power failure. However, a precondition for zero stroke is a minimum pressure between 8 and 12 bar, which the pump has to build up as pilot pressure. This can always be ensured, when no oil can flow away from the pump output (e.g. actuator line hydraulically blocked).

Observe the special case of suspended loads!

Activation sequence of digital electronics SYDFED

Switching on

1. Voltage supply of the electronics
2. Set controller enable
3. Switch motor on
4. Suppress warnings until target speed has been reached
5. Open check valve (if provided)

Switching off

1. Command value provision: $a_{comm} = 5\%$ and $p = 10\text{ bar}$
2. Close check valve (if provided)
3. Suppress warnings
4. Switch el. motor off
5. Switch voltage supply of electronics off

5.12 IDENTIFICATION OF THE PRODUCT

All SY(H)DFE control systems can be identified on the nameplate. The figure below shows an example of a SYDFEE nameplate

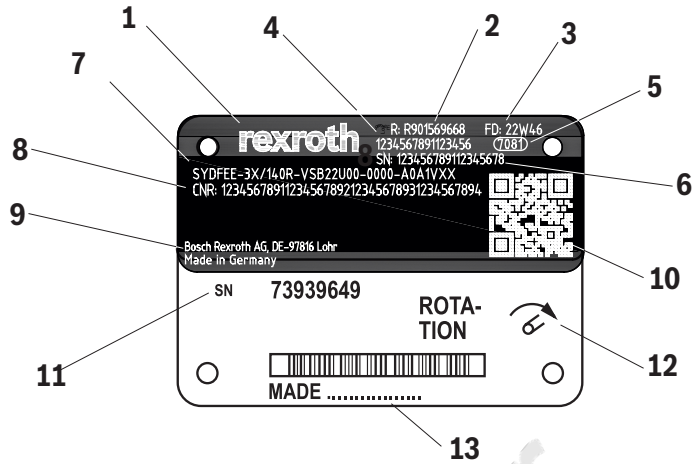

Fig. 15: Nameplate

| Field | Designation |
|-------|--|
| 1 | Brand mark |
| 2 | Material number (Rexroth product) |
| 3 | Manufacturing date |
| 4 | Customer order, job order or project number |
| 5 | Plant |
| 6 | Serial number |
| 7 | Type designation |
| 8 | Customer material number |
| 9 | Designation of origin |
| 10 | QR code |
| 11 | Serial number of base pump |
| 12 | Indication of direction of rotation of base pump |
| 13 | Designation of origin |



For queries with regard to the pump combination you must indicate the material number and the fabrication number.

6 Transport and storage

6.1 TRANSPORTING THE SY(H)DFED CONTROL SYSTEM

SY(H)DFED control systems can be transported using a fork lift truck or lifting gear.

- ▶ Make sure that the load-carrying capacity of your fork lift truck or lifting gear is sufficient.

Weights

Table 9: Weights

| SYDFED 2X / size | | | 18 | 28 | 45 | 71 | 100 | 140 |
|-------------------|--|----|-----|-----|-----|-----|-----|-----|
| Weight | Pump without through-drive, incl. pilot valve | kg | 14 | 17 | 23 | 35 | 47 | 62 |
| | In addition, pre-load valve | kg | 3.3 | 3.3 | 3.3 | 6.3 | 6.3 | 6.3 |
| | In addition, in case of external actuating system supply | kg | 2 | 2 | 2 | 2 | 2 | 2 |
| SYDFED 3X / size | | | 71 | 100 | 140 | 180 | | |
| Weight | Pump without through-drive, incl. pilot valve | kg | 49 | 71 | 75 | 80 | | |
| | In addition, pre-load valve | kg | 6.3 | 6.3 | 6.3 | 6.3 | | |
| | In addition, in case of external actuating system supply | kg | 2 | 2 | 2 | 2 | | |
| SYHDFED 1X / size | | | 125 | 180 | 250 | 355 | | |
| Weight | Pump without through-drive, incl. pilot valve | kg | 100 | 115 | 197 | 220 | | |

The dimensions vary depending on optional equipment. The values applicable to your SY(H)DFED control system can be found on the installation drawing or in the data sheet of the relevant control system.

Carrying the SY(H)DFED control system

SY(H)DFED control systems of a low weight can be transported manually, if required (the weight for brief lifting should not exceed 15 kg for women and 25 for men).

CAUTION! Danger caused by heavy loads!

Carrying heavy control systems can cause health damage!

- ▶ When carrying the control system, apply suitable techniques for lifting, lowering and relocating or use suitable lifting gear.
- ▶ Use personal protective equipment (e.g. safety goggles, protective gloves, suitable workwear, safety shoes)
- ▶ Don't transport the control system at sensitive attachments (e.g. sensors or valves).
- ▶ Put the control system carefully on the supporting surface in order that it is not damaged.

6.1.1 Transport using lifting gear

! WARNING

Danger caused by suspended loads!

Injury caused by control system falling down.

- ▶ Make sure that the control system is safely fastened.
- ▶ You may guide the control system by hand only for fine positioning and for preventing swinging of the load.
- ▶ Never walk under or reach out for suspended loads.

Please observe the following points for transporting:

- Properties of the load (e.g. weight, center of gravity, mounting and attachment points).
- Way of attaching or suspending the load
- Make sure that the load carrying capacity of the lifting gear is sufficient for transporting the SY(H)DFED control system without any risks.
- Use textile slings according to DIN EN 1492-2.



For further information on transportation, please contact Bosch Rexroth.

For transporting, the SY(H)DFED control system can be connected to a lifting device using a ring screw or a lifting strap.

Transport with ring screw

The drive shaft can be used to transport the SY(H)DFED control system as long as only outward axial forces occur. Consequently, you can suspend the SY(H)DFED from the drive shaft.

- ▶ To do this, screw a ring screw completely into the thread on the drive shaft. The size of the thread is stated in the installation drawing.
- ▶ Make sure that each ring screw can bear the total weight of the SY(H)DFED control system plus approx. 20 %.

You can lift the SY(H)DFED control system without any risk of damage as shown in Fig. 16 using the ring screw screwed into the drive shaft.

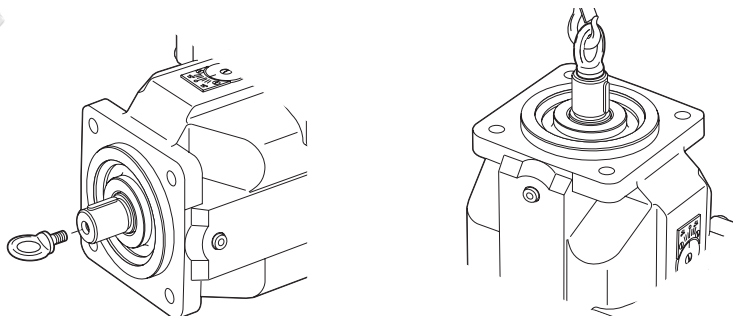

Fig. 16: Fixing the ring screw

Transport with lifting strap

- ▶ Place the lifting strap around the SY(H)DFED control system in such a way that it neither passes over the attached parts (e.g. valves) nor such that the SY(H)DFED control system is hung from attached parts (see Fig. 17).

CAUTION! Risk of injury!

During transport with a lifting device, the control system can fall out of the lifting strap and cause injuries.

- ▶ Hold the control system with your hands to prevent it from falling out of the lifting strap.
- ▶ Use the widest possible lifting strap.

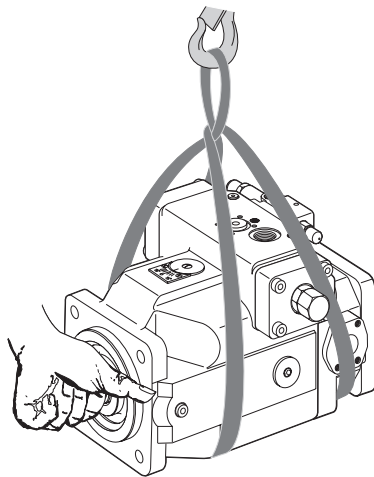

Fig. 17: Transport with lifting strap



Transport damage must be reported to your contact in the sales organization within one week. You can find the addresses of our sales locations on the Internet at:

<http://www.boschrexroth.com>

6.2 STORING THE SY(H)DFED CONTROL SYSTEM

Some SY(H)DFED control systems are shipped in an anti-corrosion foil (max. storage time: 12 months). Without anti-corrosion foil, corrosion protection is limited to transport (a few days). If these control systems are to be stored, then you must provide preservation like for storage after demounting (see below).

Requirement

- Do not store the hydraulic component outdoors but in a well ventilated room.
 - The storage rooms must be dry and free from corrosive materials and gasses.
 - For the permissible storage temperature, please refer to the relevant data sheet.
 - Avoid intense light.
 - Do not stack SY(H)DFED control systems and store them shock-proof and slip-proof.
 - SY(H)DFED control systems are very heavy (see also Table 9 “Weights“ on page 38). In this connection observe the admissible load-bearing capacities of your storage system.
- ▶ Check the SY(H)DFED control system monthly for proper storage.

Procedure after expiration of the maximum storage time:

1. Check the entire SY(H)DFED control system for damage and corrosion prior to installation.
2. Check the SY(H)DFED control system for proper function and leaks during a test run.
3. Replace the shaft seal ring when the storage time of 24 months is exceeded.



After expiration of the maximum storage time, we recommend that you have the SY(H)DFED control system inspected by your responsible Rexroth Service partner.

Should you have questions regarding spare parts, contact your Rexroth Service partner responsible for SY(H)DFED control systems, see chapter 10.5 "Spare parts", page 75.

Following demounting

If a dismantled SY(H)DFED control system is to be stored, it must be preserved against corrosion for the duration of storage.



The following instructions only refer to SY(H)DFED control systems, which are operated with a hydraulic fluid based on mineral oil. Other hydraulic fluids require preservation methods that are specifically tailored to them. In such a case, consult with the Rexroth Service (for address, see chapter 10.5 "Spare parts", page 75).

Rexroth recommends the following proceeding:

1. Drain the SY(H)DFED control system completely.
 2. Clean the SY(H)DFED control system, see also chapter 10.1 "Cleaning and care", page 73.
 3. For storage times up to 12 months: Wet the SY(H)DFED control system internally by filling in about 100 ml of mineral oil.
For storage times up to 24 months: Fill the SY(H)DFED control system with anti-corrosion agent VCI 329 (20 ml).
Filling via the case drain port.
 4. Plug all ports air-tight.
 5. Wet non-varnished external metal surfaces of the SY(H)DFED control system with a suitable anti-corrosion agent.
 6. Pack the SY(H)DFED control system air-tight together with a desiccant in an anti-corrosion foil.
 7. Protect the SY(H)DFED control system against impacts during storage. For further conditions, see "Requirements" above.
- In each case, please observe any applicable provisions and laws regarding the handling of substances hazardous to water or to health.

7 Installation

Before starting to install the system, have the following documents at hand:

- Hydraulic circuit diagram for the system (made available by the machine manufacturer)
- Data sheet of the SY(H)DFED control system (contains the technical data)
- Order confirmation (contains the preset data of the SY(H)DFED control system)

7.1 UNPACKING

CAUTION

Parts falling out!

If the packaging is not opened correctly, parts may fall out and cause injury.

- ▶ Put the packaging on level, bearing ground.
- ▶ Only open the packaging from the top.

SY(H)DFED control systems are delivered packed in an anti-corrosion foil made of polyethylene material.

- ▶ Dispose of the packaging in accordance with the national regulations of your country.

7.2 INSTALLATION CONDITIONS

- ▶ Adhere to all limits specified in the data sheet regarding temperature, viscosity, cleanliness of the hydraulic fluid.
- ▶ Make sure that the housing of the SY(H)DFED control system is filled with hydraulic fluid during commissioning and in operation. This must also be observed during longer periods of standstill, because the SY(H)DFED control system may drain via the hydraulic lines.
- ▶ To achieve favorable noise values, decouple all connecting lines from all components that can vibrate (e.g. tank) using elastic elements.
- ▶ Make certain that the suction line, case drain line, and return line flow into the tank below the minimum fluid level in all operational states.
- ▶ Strictly observe utmost cleanliness. The SY(H)DFED control system must be installed without any contamination. Contamination of the hydraulic fluid can significantly affect the service life of the SY(H)DFED control system.
- ▶ Do not use cotton waste or linty cloths for cleaning.
- ▶ Use suitable liquid cleaning agents to remove lubricants and other difficult-to-remove dirt. Cleaning agents must not penetrate the hydraulic system.

7.3 INSTALLATION POSITIONS AND PIPING OF SY(H)DFED SYSTEMS

7.3.1 General information

The installation orientation and position of the SY(H)DFED control system essentially determine the procedures during installation and commissioning (such as for filling the axial piston unit).

Note that you can expect certain installation positions to affect the control behavior or the adjustment feature. Because of gravity, dead weight and case pressure, minor characteristic curve offsets and changes in actuating time may occur.

The installation instructions are tailored to the use of the SY(H)DFED control system. Adhering to these instructions is one of the decisive factors for the service life of the units.

The instructions refer to standard types and standard installation situations. Particular installation situations require additional measures to be taken on the unit, which are documented separately.

Generally, care must be taken that during commissioning and re-commissioning of a system or equipment, the entire case of the axial piston unit is filled with hydraulic fluid and remains filled during operation.

NOTICE! Insufficient hydraulic fluid!

Risk of damage or destruction of the rotary group!

- ▶ Each control system type has its optimum filling orientation. Only this orientation allows complete filling of the case, which is the reason why this orientation must be adhered to during commissioning. For re-commissioning, this orientation should be complied with as far as possible.

In the following, we distinguish between the installation position (pump/motor in relation to tank) and the installation orientation (position of the pump/motor shaft end vertical, horizontal, etc.).

Installation position

The following installation positions are possible (see Fig. 18):

- Pos. a): Pump/motor above the tank (above minimum oil level)

NOTICE! Risk of damage due to loss of hydraulic fluid!

With an installation position above the tank, the case interior may drain through the case drain line after longer standstill periods (air enters via the shaft seal ring) or via the service line (gap leakage). The bearings are thus insufficiently lubricated when the pump is restarted.

- ▶ Check the hydraulic fluid level in the pump case at regular intervals; if required, carry out re-commissioning.

- Pos. b): Pump/motor next to or below the tank (below minimum oil level), with the upper edge of the case corresponding to the minimum oil level.
- SY(H)DFED control systems cannot be installed in the tank. Use control system SY(H)DFE1 for oil-immersed applications.

The following installation positions are permitted. The pipe routing shown represents the general routing.

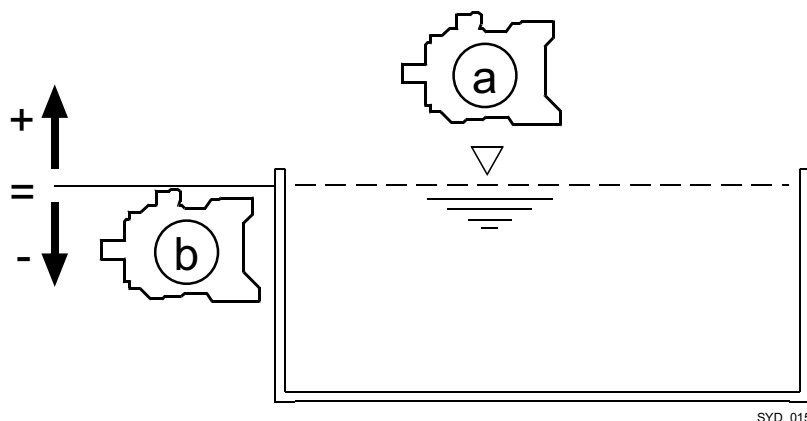

Fig. 18: Installation position

Installation orientation

The following installation orientations are possible:

- Pos.1 horizontal: Shaft end horizontal
- Pos.2 vertical: Shaft end upwards
- Pos.3 vertical: Shaft end downwards (possible only with pump variant 0975)

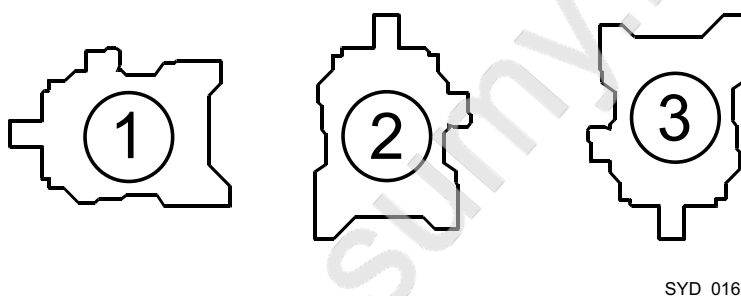

Fig. 19: Installation orientations

7.3.2 Piping

The installation positions and installation orientations shown in Figs. Fig. 18 and Fig. 19 determine the installation of

- suction lines
- case drain lines
- bleed lines

Make sure for all installation positions that always the higher of drain ports “L” or “L1” is piped. Moreover, the distance between the end of installed pipes and the minimum oil level must not be shorter than the specified minimum distance (immersion depth “E”)

To be noticed

When installing suction and case drain lines, take care that the routing is straight and short and has as few bends as possible.

When the system is at rest, the lines drain automatically in the course of time due to the own weight of the hydraulic fluid.

Moreover, the different specific densities of hydraulic fluids must be taken into account, since fluids with a higher density are more difficult to aspire and also flow down more quickly. The limit speeds for hydraulic fluids with high density (\geq mineral oil 0.87 g/ml) are specified in data sheet RE 90223.

For pumps, a minimum suction pressure is prescribed for port “S” irrespective of installation positions and installation orientations:

minimum suction pressure ≥ 0.8 bar abs.

To establish the suction pressure (inlet pressure) p_{abs} in dependence on the displacement or speed, please observe the technical data given in data sheets RE 30030, 30630 and 30035.

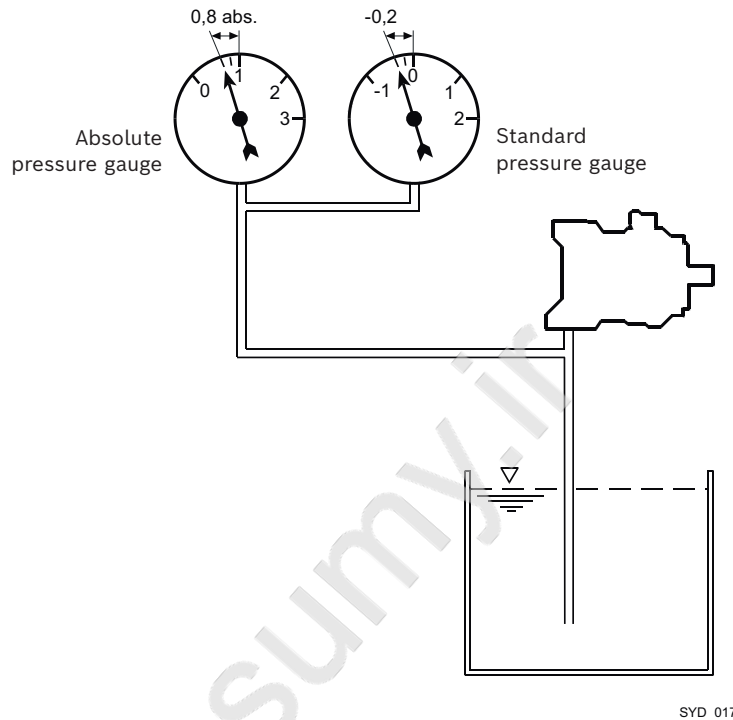

Fig. 20: Minimum suction pressure

Case drain piping

Dynamic swiveling processes result in increased case pressures that are caused by the acceleration phase of the case drain oil column. They occur within milliseconds and must not exceed 6 bar_{abs.}. They are influenced by the inductive resistance of the case drain line ($\Delta p_i = f(\text{diameter, length})$). Here, the flow resistance at the case drain fitting on the pump case plays a subordinate role.



The Δp_i value can only be improved by a larger nominal width of the case drain line.

General notes

Generally, the following must be observed:

- ▶ Each pump should preferably be piped with a separate case drain line.
- ▶ Direct the case drain fluid in the case chamber via the highest case drain port and as shortly as possible (ca. 1 m) directly to the tank. Use a line size, which matches the port.
- ▶ When the specified line lengths are exceeded we recommend that the nominal width be increased by one size per additional meter.
- ▶ The nominal width of the case drain line determined by the threaded connection on the pump case must not be reduced. Use “light series” pipes only.
- ▶ Do not use check valves in case drain lines.
- ▶ The case drain line should always enter the tank in the return flow chamber below the oil level. For tank designs without direct separation of the suction

chamber, the drain line should be returned to the tank as far away as possible from the suction port.

- ▶ External influences of pressure, e.g. from manifold tank lines, on the pump drain port or the pump case are not permitted.

7.4 INSTALLING THE SY(H)DFED CONTROL SYSTEM

CAUTION

Uncontrolled movements of the control system!

Risk of injury.

- ▶ Make sure that the SY(H)DFED control system is properly mounted.

NOTICE

Damage caused by missing seals and plugs!

Liquids and foreign particles may penetrate and damage the product.

- ▶ Before starting the installation make sure that all seals and plugs of connections are tight.
- ▶ Do not install the SY(H)DFED control system in a tank below the fluid level (in-tank installation)!

7.4.1 Preparations

1. Check the scope of delivery for completeness and damage in transit.
2. Compare the material number and designation (ordering code) with the details on the order confirmation.



If the material number for the SY(H)DFED control system does not correspond to the one on the order confirmation, contact Rexroth Service for clarification. For the address, see chapter 10.5 "Spare parts" on page 75.

3. Before installing the SY(H)DFED control system, empty it completely to prevent mixing with the hydraulic fluid used in the system.
4. Check the direction of rotation of the SY(H)DFED control system (on the nameplate) and make sure that this corresponds to the direction of rotation of the motor.



The direction of rotation as specified on the nameplate shows the direction of rotation of the SY(H)DFED control system as viewed on the drive shaft. For information on the direction of rotation of the motor, please refer to the motor manufacturer's operating instructions.

7.4.2 Dimensions of connections

The data sheet contains the dimensions for all connections to the SY(H)DFED control system. Also observe the instructions provided by the manufacturers of the other components when selecting the required tools.

7.4.3 General notes

When installing or removing the SY(H)DFED control system, observe the following general notes and instructions for action:

- ▶ Mount the SY(H)DFED control system so that the expected forces and torques can be transmitted without any risks.
- ▶ The permissible axial and radial loading of the drive shaft, the permissible torsional vibration, the optimum direction of load force, as well as the limit speeds can be found in the data sheet.

7.4.4 Installation with coupling

The SY(H)DFED control system is usually flange-mounted to a motor with a coupling. If you plan to install the unit otherwise, please consult us.

How to install the SY(H)DFED control unit with a coupling is described in detail in the following:

1. Mount the relevant coupling half onto the drive shaft of the SY(H)DFED control system according to the instructions of the coupling manufacturer.



The drive shaft end of the SY(H)DFED control system is provided with a threaded bore. Use this threaded bore to mount the coupling element on the drive shaft. Refer to the installation drawing for the dimensions of the threaded bore.

2. Make sure that the installation location is clean and free from dirt and foreign particles.
3. Positively clamp the coupling hub on the drive shaft or ensure permanent lubrication of the drive shaft. This prevents the formation of frictional corrosion and associated wear.
4. Transport the SY(H)DFED control system to the installation location.
5. Mount the coupling to the drive in accordance with the instructions of the coupling manufacturer.



The SY(H)DFED control system must not be tightened down until the coupling has been correctly assembled.

6. Mount the SY(H)DFED control system at the installation location.
7. If necessary, details on the required tools and tightening torques for the mounting screws are available from the machine or system manufacturer.
 - For bell housing mounting, check the coupling axial play through the bell window according to the manufacturer's instructions.
 - For flange installation, align the support of the SY(H)DFED control system with the drive.
8. When using flexible couplings, check that the drive is free of resonance after having completed the installation.

7.4.5 Completing the installation

CAUTION

Ejected plastic plugs!

Risk of injury. Operating the SY(H)DFED control system with plastic plugs can cause injuries or damage to the SY(H)DFED control system.

- ▶ Before commissioning, remove all plastic plugs and plug all non-connected ports with suitable, pressure-proof metal plug screws, because plastic plugs are not pressure-proof.

1. Remove transport screws, if fitted.

2. Remove the transport protection.

The axial piston unit of the SY(H)DFED control system was delivered with protective covers and plastic plugs or plug screws. These must be removed before the system can be connected. Use appropriate tools for this.

3. Make certain that the sealing and functional surfaces are not damaged.

Setscrews, if provided, are protected against unauthorized resetting by means of protective caps. Removing protective caps will void the warranty. If you need to modify the setting, please contact the responsible Rexroth Service (for address, see chapter 10.5 "Spare parts" on page 75).

For the variant with through-drive, mount the auxiliary pump in accordance with the instructions of the pump manufacturer.



7.5 CONNECTING THE SY(H)DFED CONTROL SYSTEM HYDRAULICALLY

WARNING

Uncontrolled system behavior due to interchanged connections!

Risk of injury! Interchanging the connections will lead to malfunction (e.g. lifting instead of lowering) and therefore represents a related hazard.

- ▶ When connecting hydraulic components, observe the specified piping according to the hydraulic circuit diagram of the machine or system manufacturer.

NOTICE

Hydraulic pipes and hoses installed under stress!

Hydraulic pipes and hoses, which are installed under mechanical stress, generate additional mechanical forces during operation, which reduces the service life of the SY(H)DFED control system and the machine or system as a whole.

- ▶ Install pipes and hoses stress-relieved.

NOTICE

Insufficient suction pressure!

Risk of damage! Generally, a minimum permissible suction pressure at port „S” is prescribed for SY(H)DFED control systems in all installation positions. If the pressure at port „S” drops below the specified values, damage may occur which may lead to the destruction of the SY(H)DFED control system.

- ▶ Make sure that the required suction pressure is achieved. This is influenced by:
 - appropriate piping of the suction cross-sections
 - appropriate pipe diameters
 - appropriate position of the tank
 - appropriate viscosity of the hydraulic fluid

The machine or system manufacturer is responsible for dimensioning the lines. The SY(H)DFED control system must be connected to the rest of the hydraulic system in accordance with the hydraulic circuit diagram of the machine or system manufacturer.



Connect exclusively hydraulic lines to the service and function ports.

- ▶ Always ensure absolute cleanliness.
- ▶ Install the SY(H)DFED control system free of dirt.
- ▶ Make sure that all ports, hydraulic lines and add-on units (e.g. measuring devices) are clean.
- ▶ Make sure that no contaminants can enter the system, also while you are closing the ports.



Observe the following notes when routing suction, pressure and case drain lines.

- ▶ See to it that the suction line (pipe or flexible hose) is as short and straight as possible.
- ▶ The line cross-section of the suction line is to be dimensioned so that the pressure in the suction port does not fall below the minimum permissible value and the maximum permissible pressure is not exceeded.
- ▶ Observe air tightness of the junctions and pressure resistance of the hose, also with respect to the atmospheric pressure.
- ▶ In conjunction with the pressure lines, make certain that the pipes, hoses and connecting elements are approved for the operating pressure range.
- ▶ Always route case drain lines so that the housing is constantly filled with hydraulic fluid and ensure that no air gets through the shaft seal ring even during extended standstill periods. Under no operating conditions may the pressure inside the case exceed the limit values specified for the SY(H)DFED control system in the data sheet. The case drain line in the tank must in any case end up below the minimum fluid level (see chapter 7.3 “Installation positions and piping of SY(H)DFED systems”, page 43).



The ports and mounting threads are rated for the operating pressures specified in the data sheet. The machine or system manufacturer must ensure that the connecting elements and lines comply with the specified operating conditions (pressure, flow, hydraulic fluid, temperature) with the necessary safety factors.

The pressure port of the SY(H)DFED control system of size 71 is provided with threads for two standard flange connection patterns:

- SAE 1“ (dot-dashed line) for pressures above 250 bar and
- SAE 1 ¼“ (dotted line) for pressures up to 250 bar.

Because standard flanges according to SAE 1 ¼" are permitted up to 250 bar only, the porting pattern to SAE 1" must be used in the case of operating pressures higher than 250 bar.

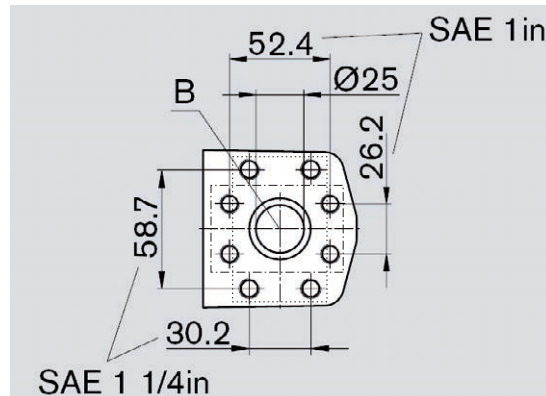

Fig. 21: Flange pattern

Procedure To connect the SY(H)DFED control system to the hydraulic system:

1. Remove the plug screws from the ports that are to be connected according to the hydraulic circuit diagram.
2. Use only clean hydraulic lines.
3. Connect the lines according to the hydraulic circuit diagram.
Either pipes or hoses must be connected to all ports according to the installation drawing and machine or system circuit diagram or the ports have to be plugged using suitable plug screws.



The installation drawing contains the dimensions of all connections and ports on the SY(H)DFED control system. Also observe the instructions provided by the manufacturers of the other hydraulic components when selecting the required tools.

4. Make sure
 - that the cap nuts are correctly tightened on the fittings and flanges (observe tightening torques!). Mark all checked fittings using e.g. a permanent marker,
 - that the pipes and hose lines and every combination of connecting pieces, couplings or connecting points with hoses or pipes have been inspected by a technically qualified person for their safe working condition.

Tightening torques The tightening torques for the SY(H)DFED control system are listed in the following table:

- Threaded hole in the axial piston unit:
The maximum permissible tightening torques M_{Gmax} are the maximum values of the threaded holes and must not be exceeded.
- Fittings:
Observe the manufacturer's instructions regarding tightening torques for the fittings used.
- Mounting screws:
For mounting screws according to DIN 13/ISO 68, we recommend checking the tightening torque in each individual case as per VDI 2230.
- Plug screws:
For the metal plug screws that come with the SY(H)DFED control system, the required tightening torques of plug screws M_V apply.

Risk of mixing up threaded connections SY(H)DFED control systems are used in applications with metric as well as with imperial systems of units.

Both, the system of units as well as the size of threaded hole and male stud (e.g. plug screw) must match.

Since the systems cannot be distinguished visually, there is a risk of mixing up.

WARNING! Wrong threaded plug!

Risk of serious injury, if a male stud is used that differs from the threaded hole in terms of unit system and size and is pressurized. The male stud may loosen itself or even be ejected from the hole in a projectile-like manner.

Hydraulic fluid can be discharged from this leakage point.

- ▶ Use the drawings (installation drawing/data sheet) to determine the required threaded plug for each fitting.
- ▶ Make certain that there are no mix-ups when assembling valves, mounting screws and plug screws.
- ▶ For all threaded holes, use a male stud from the same system of units and of the correct size.

Table 10: Tightening torques of threaded holes and plug screws

| Thread size of ports | | Max. permissible tightening torque of threaded holes M_{Gmax} | Required tightening torques for plug screws M_V | A/F hexagon socket |
|----------------------|-----------|--|---|--------------------|
| M10x1 | DIN 3852 | 30 Nm | 12 Nm | 5 mm |
| M12x1.5 | DIN 3852 | 50 Nm | 25 Nm | 6 mm |
| M14x1.5 | DIN 3852 | 80 Nm | 35 Nm | 6 mm |
| M16x1.5 | DIN 3852 | 100 Nm | 50 Nm | 8 mm |
| M18x1.5 | DIN 3852 | 140 Nm | 60 Nm | 8 mm |
| M22x1.5 | DIN 3852 | 210 Nm | 80 Nm | 10 mm |
| M26x1.5 | DIN 3852 | 230 Nm | 120 Nm | 12 mm |
| M27x2 | DIN 3852 | 330 Nm | 135 Nm | 12 mm |
| M33x2 | DIN 3852 | 540 Nm | 225 Nm | 17 mm |
| M42x2 | DIN 3852 | 720 Nm | 360 Nm | 22 mm |
| 5/16-24 UNF-2B | ISO 11926 | 10 Nm | 7 Nm | 1/8 in |
| 3/8-24 UNF-2B | ISO 11926 | 20 Nm | 7 Nm | 5/32 in |
| 7/16-20 UNF-2B | ISO 11926 | 40 Nm | 15 Nm | 3/16 in |
| 9/16-18 UNF-2B | ISO 11926 | 80 Nm | 25 Nm | 1/4 in |
| 3/4-16 UNF-2B | ISO 11926 | 160 Nm | 62 Nm | 5/16 in |
| 7/8-14 UNF-2B | ISO 11926 | 240 Nm | 127 Nm | 3/8 in |
| 1 1/16-12 UN-2B | ISO 11926 | 360 Nm | 147 Nm | 9/16 in |
| 1 5/16-12 UN-2B | ISO 11926 | 540 Nm | 198 Nm | 5/8 in |
| 1 5/8-12 UN-2B | ISO 11926 | 960 Nm | 320 Nm | 3/4 in |
| 1 7/8-12 UN-2B | ISO 11926 | 1200 Nm | 390 Nm | 3/4 in |

For the tightening torques for spare parts, please refer to the data sheet.

7.6 CONNECTING THE SY(H)DFED CONTROL SYSTEM ELECTRICALLY

The machine or system manufacturer is responsible for setting up the electrical control.

For electrically controlled SY(H)DFED control systems, the electrical control must be connected according to the circuit diagram of the machine or system manufacturer.



Damage to the control system caused by incorrect installation is not covered by the warranty!

CAUTION! Live installation!

Risk of injury when plugging or unplugging connectors under voltage.

- ▶ Before carrying out any installation work or plugging or unplugging connectors from the product, disconnect the device from the power supply or the voltage source or de-energize it reliably. Damage to the control system caused by incorrect installation is not covered by the warranty!

1. Disconnect the relevant system part from the power supply.
2. Connect the SY(H)DFED control system electrically (24 V).

7.6.1 Cabling of electronic components



Generally, the following is valid:

- Keep the number of intermediate terminals to a minimum.
- The arrangement of electromagnetic sources of interference in the direct vicinity of the pilot valve is not permitted.
- Installing power cables in the vicinity of the pilot valve is not permitted.
- Due to the use in a hydraulic environment, use only cable material that is specified as “oil-proof”. Otherwise, possible hardening of the cable jacket could lead to embrittlement and thus to breaking of individual wires.
- Select only cables that have the actually required number of wires (avoid superfluous wires).
- Cables for command values and actual values should be as short as possible.
- The signal cables to the pilot valve must in any case be shielded. The cable shield must be connected to ground on one end in the control cabinet.
- Strip the shield as short as possible and connect it in accordance with the data given in the RE data sheets.
- The contacts on the mating connector must not be exposed to mechanical stress. This can lead to a defective connection between the mating connector and the plug-in connector.

Due to the fact that the control electronics is integrated in the valve housing in the factory, no additional cabling is required for the position transducer systems of the pump and the valve.

Cabling of the control system is therefore restricted to the connection of the 12-pin central connector of the integrated electronics to the customer's control, the pressure sensor and the field bus connection, if provided.

For this connection, ready-to-connect and standardized cable kits are available in different lengths. On request, the 12-pin mating connector can be supplied separately for individual designs. See data sheet.

The HM20-2X/...-F-C13 pressure transducer is fitted with a ready-to-connect, standardized connection cable for direct connection to the X2M1 or X2M2 connection port.

7.6.2 Electrical connection of the pilot valve

Pinout of central connector

The following table shows the pinout of the central connector 11 + PE pilot valve VT-DFPD. The column “code” refers to the cable kit that can be ordered as optional accessories.

Bosch Rexroth offers the following cable kits:

Type: Plug-in connector 11+PE for central connector XH4

- Without cable (construction kit) Mat. no. R900884671
- With cable kit 2 x 5 m Mat. no R900032356
- With cable kit 2 x 20 m Mat. no. R900860399

Table 11: Signals to the central connector

| Pin | Signal | Description | Signal direction | Signal type | Pin assignment in cable set (accessories) |
|------|-------------------------|---|------------------|--|---|
| 1 | + UB | Power supply | IN | 24 VDC | 1 |
| 2 | 0 V = L0 | Reference potential for voltage supply | - | - | 2 |
| PE | Ground | Ground connection for the electronics | - | - | Green/ yellow |
| 3 | DO | Switching output 24 V, max. 1.5 A Factory setting: Error signal | OUT | Logical 24 V | White |
| 4 | M0 | Reference potential for analog signals | - | - | Yellow |
| 5 | AI2 | Analog input 2 (or digital input, to be configured using software) | IN | Analog ±10 V (digital 24 V) | Green |
| 6 | AO2 | Analog output 2 Factory setting: Actual swivel angle value normalized | OUT | Analog ±10 V or 0...20 mA ¹⁾ | Violet |
| 7 | AI1 | Analog input 1 (or digital input, to be configured using software) | IN | Analog ±10 V (digital 24 V) | Pink |
| 8 | AO1 | Analog output 1 Factory setting: Actual pressure value normalized | OUT | Analog ±10 V or 0...20 mA ¹⁾ | Red |
| 9 | DI | Digital input (use freely configurable) | IN | Logical 24 V | Brown |
| 10 | Actual pressure value H | Actual pressure value input (analog input 8): Signal level dependent on parameter setting. | IN | Analog 0 ... 10 V (freely configurable) | Black |
| 11 | Actual pressure value L | Factory setting depending on option 9 in the ordering code: 0 ... 10 V (V) or disabled (F) | - | Analog | Blue |
| n.c. | | | | | Gray |

¹⁾ If analog inputs AI1 and AI2 are not used, the analog outputs AO1 and AO2 may be configured as current outputs (e.g., when command values are to be provided over the field bus).



Connect M0 and L0 in the control cabinet to prevent potential shifts.

7.6.3 Connection to the swivel angle sensor

The swivel angle of the pump is acquired by swivel angle sensor VT-SWA...G15, which is directly connected to pilot valve VT-DFPD in the factory. The sensor is supplied by pilot valve VT-DFPD.

7.6.4 X2M1 and X2M2: Analog, configurable sensor interface (coding A), M12, 5-pin, socket

Table 12: Pinout of X2M1 and X2M2

| Pin | Pin assignment |
|-----|--|
| 1 | + 24 V voltage output (sensor supply) ¹⁾ |
| 2 | Sensor signal input current (4 ... 20 mA) ²⁾ |
| 3 | GND |
| 4 | Sensor signal input voltage (0 ... 10 V) ²⁾ |
| 5 | Negative differential amplifier input for pin 4 (optional) |

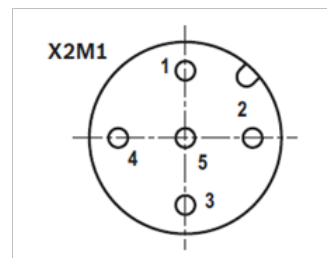

1) Maximum load-carrying capacity 50 mA, voltage output identical to the voltage supply applied to input XH4.

2) Only one signal input can be configured per interface

7.6.5 X7E1 and X7E2: Plug-in connector pinout for Ethernet interface (coding D), M12, 4-pin, socket

Table 13: Pinout of X7E1 and X7E2:

| Pin | Pin assignment |
|-----|----------------|
| 1 | TxD + |
| 2 | RxD + |
| 3 | TxD - |
| 4 | RxD - |
| 5 | not assigned |

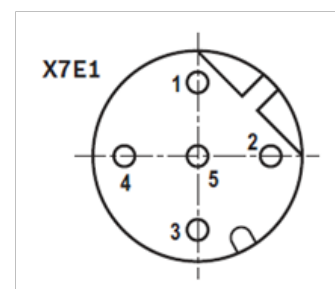

Use a shielded data cable as bus cable. The shield should be connected to the connector housing.

7.6.6 LED status indicator lamps

| LED | Interface | Sercos | EtherNet/IP | EtherCAT | PROFINET |
|-----|--------------------|---------------|----------------|----------------|----------------|
| 1 | X7E1 | Activity | Activity | not used | Activity |
| 2 | | Link | Link | Link/activity | Link |
| 3 | Electronics module | S | Network status | Network status | Network status |
| 4 | | Module status | Module status | Module status | Module status |
| 5 | X7E2 | Activity | Activity | not used | Activity |
| 6 | | Link | Link | Link/activity | Link |

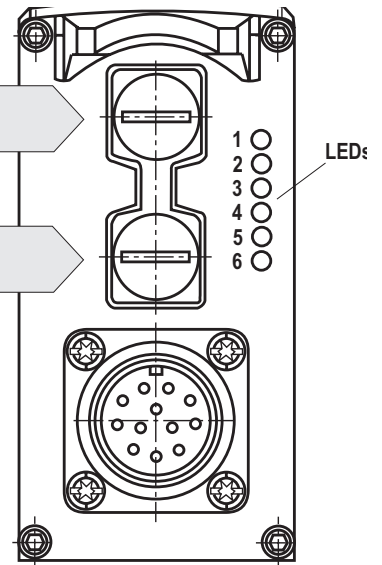

Table 14: Indication of status LED

| Module status LED (LED 4) | Indication status |
|---------------------------|---------------------------|
| Off | No voltage supply |
| Green/red blinking | Self-test |
| Flashing green | Drive ready for operation |
| Green | in control |
| Flashing red | Warning |
| RED | Error |

| Network status LED | Indication status |
|--------------------|-------------------|
| Off | No voltage supply |
| Green | Operation |



LEDs 1, 2, 5, and 6 refer to the interfaces "X7E1" and "X7E2"
 - Link: Cable plugged, connection is established (solid on)
 - Activity: Data sent/received (blinking)
 The module status LEDs 3 and 4 refer to the electronics module
 For a detailed description of the diagnostic LEDs, please refer to the functional description of Rexroth HydraulicDrive.

7.6.7 Power supply of the VT-DFPD pilot valve

The pilot valve VT-DFPD is supplied with 24 V DC voltage. If this voltage supply is not provided on the part of the system, power supply unit VT-NE30-2X/ according to RE 29929 can be used. The 24 V supply of the power supply unit is to be connected to connections 1 (+24 V) and 2 (L0) of the mating connector.

In the case of the connection cable optionally available, this refers to the 2 black wires of the 3-pin cables with a cross-section of 1 mm². Connect the wire marked with "1" to +24 V and the wire marked with "2" to L0 (ground). Connect the yellow/green wire to ground.

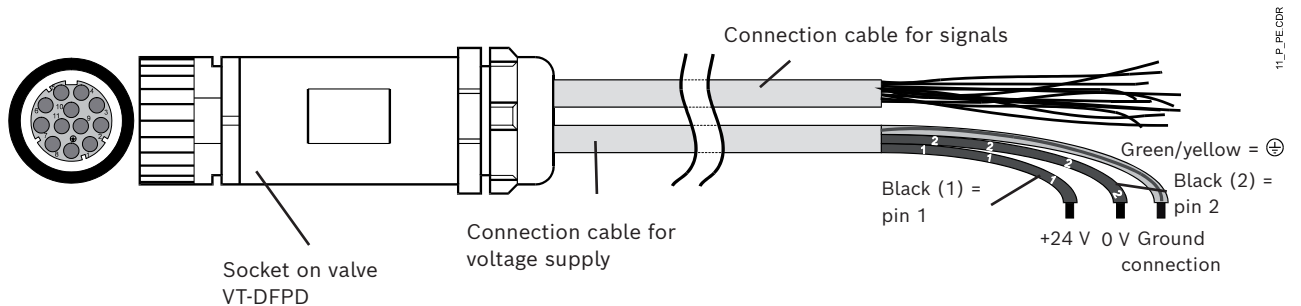

Fig. 22: Connection of power supply

**Recommendation:**

The voltage supply for the VT-DFPD pilot valve should be protected with a 4 A/ slow-blowing fuse on the system side.

The pilot valve is not provided with an enable input to block the function of the valve.

In the event of an error, the controller enable should be withdrawn via field bus. All further, safety-relevant interventions must be made by the higher-level control (e.g. switching the drive motor OFF, closing the shut-off valves, ...).

7.6.8 Selection, place of installation and mounting orientation of the pressure transducer

Selection of the pressure transducers

To reduce the number of variants, only pressure rating “315 bar” is given in the ordering code of the SY(H)DFED control systems. If required, other pressure ratings can be combined (with the correct selection of the relevant electrical interface!). Such pressure transducers must, however, be ordered separately for the SY(H)DFED control system.

In terms of signals, the sensors have to be distinguished as follows:

- Sensors with current interface and
- Sensors with voltage interface

Here, the usual signal limits are between 0...20 mA or 0...10 V, respectively.

Within these limits, there are further modifications that depend on further options, such as monitoring for cable break.

From a technical point of view, the efficiency of the pressure transducer must be adapted to the SY(H)DFED system in order that the best possible results can be obtained with regard to accuracy, dynamics and repeatability.

The pressure transducers recommended by us are listed in the RE data sheets of the relevant SY(H)DFED system.

- Our pressure transducer model “HM20-2X“ with current interface (4...20 mA) is provided with a 2-conductor connection and allows the fail-safe transmission of signals – even over greater distances (depending on the cable used and the permitted load of the pressure transducer). Further pick-offs can be looped in taking into account the relevant input resistances.
- Our pressure transducer model “HM20-2X“ with voltage interface (0...10 V) has a 3-conductor connection and an integrated DC/DC converter, which effectively rules out disturbances on the analog signal caused by the voltage supply. The transmission of the signal over longer distances should be avoided. The advantage of the pressure transducer lies in the simple checking of the signals by measurement using a voltmeter without intervention into the connection cables.
- The “HM20-2X/...F-C13” pressure transducer has a voltage interface (0.5...5 V) with a ready-to-connect, standardized connection cable for direct connection to X2M1 or X2M2.

CAUTION! Uncontrolled increase in pressure!

Risk of injury!

- ▶ The pressure transducer must be wired so that it cannot be short-circuited, because in the event of a missing pressure signal, the control electronics can no longer detect the pressure, which causes an uncontrolled increase in pressure.

Observe the operating instructions of the pressure transducer HM20, RE 30272-B.

Place of installation of the pressure transducer

Favorable places of installation of pressure transducers turned out to be not in the direct vicinity of the pump, but, for example, downstream of the (flexible) pressure hose:

- Always between pump and check valve (if fitted)
- Do not use minimess lines



The installation in port “MP1“ of pre-load valve SYDZ is only possible with pressure transducer HM20-2X/...F-C13 for reasons of dimensions. In this case, it may be required to reduce the pressure controller gain due to higher pressure pulsation.

Mounting orientation of the pressure transducer

We recommend suspended mounting of the pressure transducer so that bleeding problems (and hence control oscillations) can be ruled out right from the start.



If, due to the installation orientation of the pump, a pressure transducer must be installed “vertically” directly in the pump or in the pre-load valve, we recommend another place of installation for the pressure transducer.

Pressure transducer HM20 (current)

HM20 pressure transducers are provided with a 2-wire current interface and can be connected to the pilot valve via connections X2M1 or X2M2.

The voltage supply for the pressure transducer must be provided in accordance with the specification.

For more details on the pressure transducer, see data sheet 30272.

Pressure transducer HM20 (voltage)

Pressure transducers of type HM20 are provided with a voltage output of 0...+10 V as actual pressure value signal and can be connected to the pilot valve.

The voltage supply for the pressure transducer must be provided in accordance with the specification.

For more details on the pressure transducer, see data sheet 30272.

8 Commissioning

WARNING

Working in the danger zone of a machine or system!

Risk of severe injury due to unsafe working.

- ▶ The machine or system may only be commissioned when safe working is ensured.
- ▶ Pay attention to and eliminate potential danger sources before commissioning the machine or system.
- ▶ Nobody may stand in the danger zone of the machine or system.
- ▶ The emergency stop button for the machine or system must be within the operator's reach.
- ▶ Always strictly observe the instructions of the machine or system manufacturer during commissioning.

Uncontrolled system behavior!

Non-connected electrical and hydraulic connections can cause malfunctions and hydraulic fluid jets to be ejected, which can injure you.

- ▶ Only commission a completely installed product.

NOTICE

Loss of protection class due to missing seals and plugs!

Liquids and foreign particles may penetrate and damage the product.

- ▶ Before commissioning, make sure that all seals and plugs of plug-in connections are tight.

Ingress of dirt!

Damage to the SY(H)DFED control system! Contamination of the hydraulic fluid results in wear and malfunction. Especially foreign bodies such as welding beads and metal chips in the hydraulic lines can damage the SY(H)DFED control system.

- ▶ Observe utmost cleanliness during commissioning.
- ▶ Make sure that no contaminants penetrate when closing the measuring ports.

Insufficient hydraulic fluid!

Insufficient amounts of hydraulic fluid can lead to destruction of the product.

- ▶ Make sure that the housing of the SY(H)DFED control system is filled with hydraulic fluid during commissioning and in operation. This must also be observed during longer periods of standstill, because the SY(H)DFED control system may drain via the hydraulic lines.

8.1 INITIAL COMMISSIONING

NOTICE

Air pockets around the bearings!

The device can be destroyed.

- ▶ Make certain that with installation orientation “drive shaft up” the pump housing is completely filled with hydraulic fluid during commissioning and in operation.
- ▶ Check the hydraulic fluid level in the pump case at regular intervals. If required, carry out recommissioning. For tank-top installation, the case chamber can run dry through the case drain line (ingress of air via the shaft seal ring) or via the working line (gap losses). The bearings are thus insufficiently lubricated when the pump is restarted.
- ▶ Ensure that the suction line is always filled with hydraulic fluid during commissioning and operation.



When carrying out any work in conjunction with commissioning of the SY(H)DFED control system, observe the general safety instructions and intended use in chapter 2 “Safety instructions“ on page 10.

8.1.1 Filling the SY(H)DFED control system

NOTICE

Spilled hydraulic fluid!

Discharging or spilling hydraulic fluid while filling the SY(H)DFED control system can lead to environmental pollution and contamination of the groundwater.

- ▶ When filling in and changing the hydraulic fluid, always place an oil drain pan under the SY(H)DFED control system.
- ▶ Observe the information in the safety data sheet for the hydraulic fluid and the instructions provided by the system manufacturer.

You will require an approved hydraulic fluid:

The machine or system manufacturer can provide you with precise data of the hydraulic fluid. Details on minimum requirements for HFC hydraulic fluids (for SYHDFED only) are available in the Rexroth publication 92053.

To ensure functional reliability of the SY(H)DFED control system, the hydraulic fluid must comply at least with cleanliness class 18/16/13 according to ISO 4406 for particle sizes 4/6/14 µm. For permissible temperatures, see data sheet of the relevant control system.



The SY(H)DFED control system should be filled using a filling and filtration unit (10 µm filtration rating). The control system must not be powered when being filled.

1. Fill and air-bleed the SY(H)DFED control system via the appropriate ports, see chapter 7.3 “Installation positions and piping of SY(H)DFED systems” on page 43. The hydraulic lines of the system must also be filled.
2. Test the direction of rotation of the drive motor. To do this, rotate the motor briefly at the lowest rotational speed (jogging). Make sure that the direction of rotation of the SY(H)DFED control system corresponds to the indication on the

nameplate, see also chapter 5.13 “Product identification”, Fig. 15 “Nameplate“ on page 37.

3. Operate the SY(H)DFED control system at low speed (jog mode) until the pump system is completely filled and bled. For checking purposes, drain the hydraulic fluid at the case drain port and wait until fluid flows out without any bubbles.
4. Make certain that all ports are either connected to pipes or plugged according to the general circuit diagram.

8.1.2 Testing the hydraulic fluid supply

The SY(H)DFED control system must always be supplied with sufficient hydraulic fluid. For this reason, the supply of hydraulic fluid must be ensured at the start of the commissioning process.

When you test the hydraulic fluid supply, constantly monitor the noise generation and check the hydraulic fluid level in the tank. If the SY(H)DFED control system becomes louder (cavitation) or the case drain fluid flows out with bubbles, this is an indication that the SY(H)DFED control system is not being sufficiently supplied with hydraulic fluid.

Notes on troubleshooting can be found in chapter 15, “Troubleshooting“ on page 81.

To test the hydraulic fluid supply:

1. Allow the drive motor to run at lowest speed.
The SY(H)DFEE control system must be operated under no-load conditions. Pay attention to leakage and noise.
2. Check the SY(H)DFED control system’s case drain line during the test. The case drain fluid should not contain any bubbles.
3. Check the suction pressure at port “S” of the SY(H)DFED control system. For the permissible value, please refer to data sheet RE 92050.
4. Check the case drain pressure at connected port “K₁“ or “K₂“. For the permissible value, refer to data sheets RE 30030 and RE 30630, respectively.

8.1.3 Performing a flushing cycle

To remove foreign particles from the system, perform a flushing run for the entire system.



Flushing is to be carried out with a separate flushing unit. Observe the instructions of the flushing unit manufacturer for the detailed procedure for carrying out flushing.

8.1.4 Connection to the control (IndraWorks)

It is assumed that IndraWorks is already installed. Otherwise, install IndraWorks as described in instructions R911393450. Then connect the SY(H)DFED system to the Ethernet port of the PC and set the IP address (TCP/IPv4) of the network connection to the IP address range of the SY(H)DFED system. The default address of the SY(H)DFED system is set to 192.168.0.1. After having configured the network connection you can open IndraWorks and start a network search:

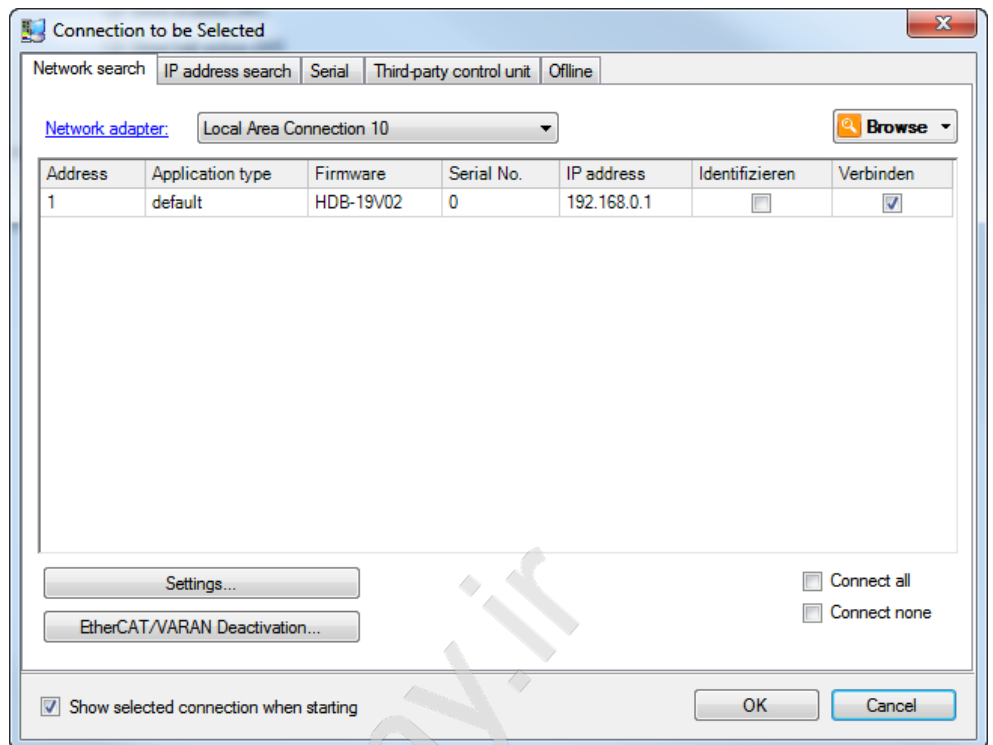

Fig. 23: Connection selection

To establish a connection to the selected system, click the OK button.



Should EtherCAT or VARAN be activated as field bus system, you can deactivate these bus systems for direct communication with IndraWorks. To this end, send the deactivation command by clicking the button “EtherCAT/VARAN Deactivation”. Alternatively, with these bus systems you can access the SY(H)DFED system directly via the Engineering port of the control.

8.1.5 Making basic settings on the control electronics

To be able to adjust the control electronics, you must have installed the engineering tool IndraWorks. The user must configure the SY(H)DFED control system according to the customer-specific requirements. This refers mainly to the following settings:

- Settings for the pressure transducer
- Settings for the swivel angle sensor
- Entry of pump and motor values

To set the enable for a test during commissioning, the use the Easy Startup Mode. It is configured and started using IndraWorks.

8.1.5.1 Settings for the pressure transducer

For some applications it may be advantageous to be able to switch between several pressure transducers. The SY(H)DFED control system offers the possibility of connecting two different pressure transducers. For this, two assignments have to be configured for the respective analog inputs with the target pressure feedback value 1 (P-0-2940) and pressure feedback value 2 (P-0-2941). The assignment with the target pressure feedback value 1 must always be provided, because the SY(H)DFED control system always requires a valid pressure feedback value for controlling. For the various options of connecting a pressure transducer, see chapter 7.6 on page 52.

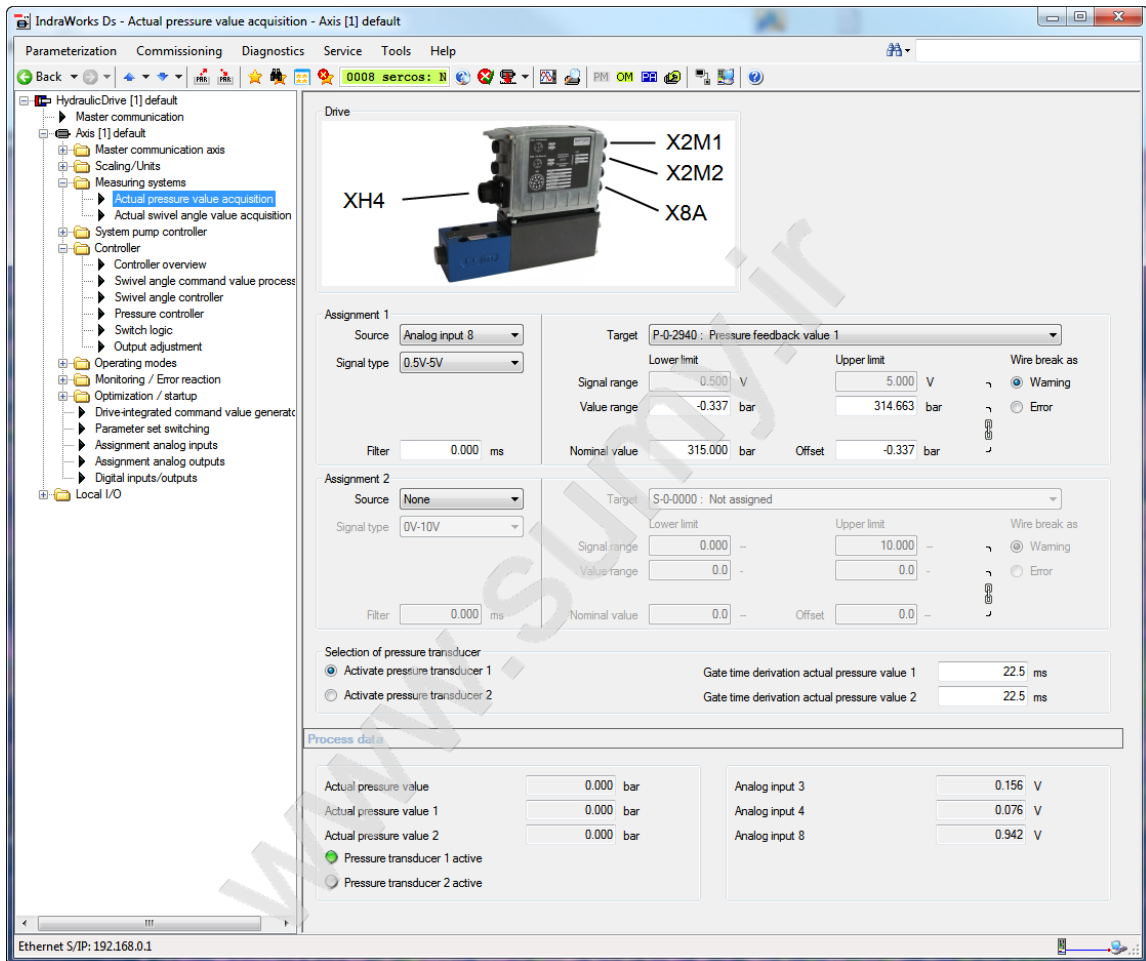

Fig. 24: Actual pressure value acquisition

8.1.5.2 Settings for the swivel angle sensor

The SY(H)DFED control system is factory-equipped with a swivel angle sensor that suits the relevant pump. Should the type of swivel angle sensor change or a spare pilot valve be mounted, the selected values may have to be adjusted in the window “Swivel angle sensing”.

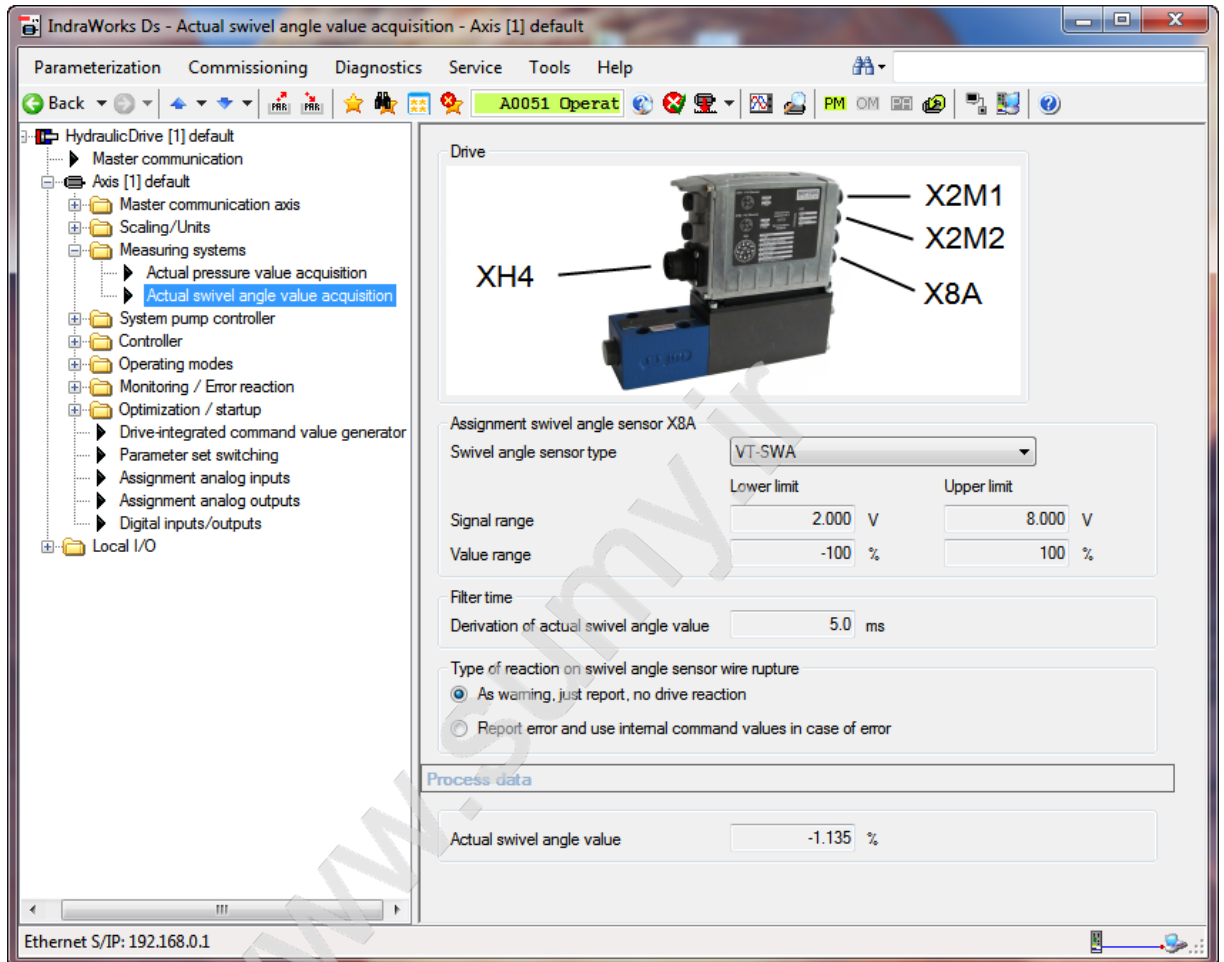

Fig. 25: Actual swivel angle value acquisition

8.1.5.3 Entry of pump and motor values

Via the structure tree “System pump controller” → “Pump/drive motor” you can open the following window. In this window you have to check the values for the displacement of the pump, the direction of rotation and the drive speed and, if required, adjust them.

This reduces the wiring effort for a master/slave circuit (see chapter 5.9 “Master/slave operation” on page 33). The master/slave function can be deactivated at any time during operation.

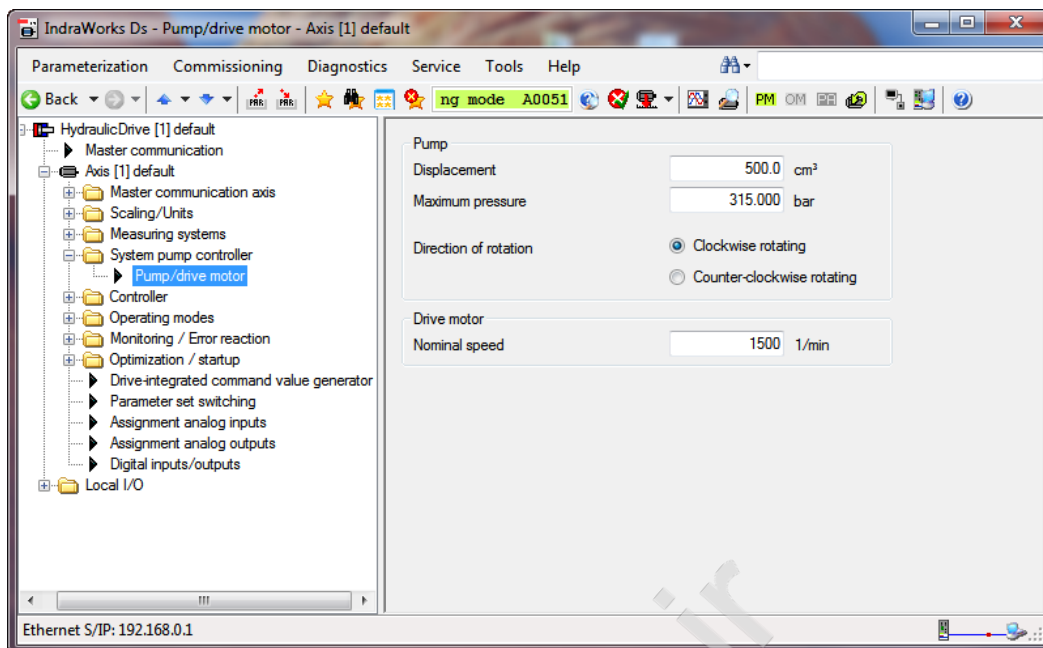

Fig. 26: Pump / drive motor

8.1.6 Switching on the drive motor of the pump

To prevent undefined states, the power supply of the valve electronics should be switched on first, then the drive motor of the pump (see chapter 5.11 “Activation sequence of electronics/hydraulics” on page 36).

Following this, you should check the following points (motor is still switched off!):

1. No error messages are present and the controller enable is set.
2. The actual swivel angle value (SWA_{act}) of the pump is in the order of $+100 \% \pm 3 \%$ (mechanical limit stop)



In this state, the warning E2282, “Control deviation pump controller” can be output, because the drive motor is still at rest. Later, when the motor is running, this warning should no longer be issued. To suppress the warning while the motor is at rest, you can enter a swivel angle command value of $>95 \%$.

Note:

Table 15: Errors and their remedy/cause

| Error | Remedy/cause |
|--|--|
| No voltage supply available | Check voltage supply at the central plug of the electronics |
| Field bus does not work | Check cabling Check IP address |
| Fault in the pressure measurement branch | Read out the actual pressure value (p_{act}); it must be 0 bar. The output signal of the pressure transducer must be compatible with the type of the control electronics (current, voltage, zero point). |
| Error in the swivel angle measurement branch | Read out the actual swivel angle value (SWA_{act}). In the case of deviations from value $+100 \% \pm 3 \%$, check the cable connection of the swivel angle sensor. |

Further explanations regarding fault analyses can be found in chapter 15 “Troubleshooting” on page 81.

1. Close all directional valves upstream of consumers.
2. Open directional valve to the oil tank for pressureless circulation.
3. Before activating the motor, feed forward small command values (e.g. $p = 15$ bar, SWA = 10 %).

In this state the VT-DFPD pilot valve signals an error (excessive control error). When the electronics works properly, the error message disappears when the motor is switched on (control error now equal to zero).

- ▶ Switch on the drive motor of the pump!

8.1.7 Bleeding the pre-load valve

WARNING

Case interior under high pressure!

Risk of injury! Loosening the screw too far can cause parts and jets of hydraulic fluid to be ejected.

- ▶ Do not turn the bleed screw out too far (max. 2 turns)!

If a pump unit is operated with a pre-load valve, this valve has to be air-bled for the initial start-up, provided that the pump does not deliver and aspire oil. Bleeding is not required, when the pump displaces oil. Bleed the pump while the system is running at low operating pressure. To this end, loosen the screw (see Figure below) by a maximum of 2 turns and wait until bubble-free oil flows out. Then, re-tighten the screw.

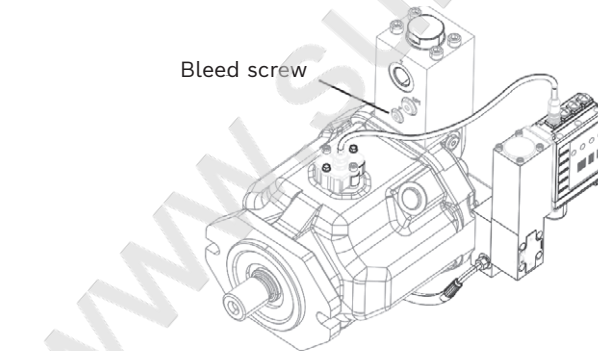

Fig. 27: Bleeding the pre-load valve

8.1.8 Setting controller parameters

The following description is to simplify setting of the controller parameters. Depending on the application, not all of the parameters listed here must be modified.

8.1.8.1 P-gain (proportional gain)

Table 16: P-gain

| Parameter | Designation |
|-----------|---------------------------------------|
| P-0-2963 | Pressure controller P-gain 1 positive |
| P-0-2964 | Pressure controller P-gain 1 negative |
| P-0-2977 | Swivel angle controller P-gain |

These controller parameters represent a linear gain, i.e. the output signal and the control deviation are in a proportional relationship. It must be noted here that the positive controller parameter (P-0-2963) is used for building up pressure, whereas the negative controller parameter (P-0-2964) is used for reducing the pressure. The smaller this value is set, the slower is the controller's response. If you select an excessively high value, the system can become unstable.

8.1.8.2 Second P-gain

Table 17: Second P-gain

| Parameter | Designation |
|-----------|--|
| P-0-2967 | Pressure controller control deviation threshold positive |
| P-0-2965 | Pressure controller P-gain 2 positive |
| P-0-2968 | Pressure controller control deviation threshold negative |
| P-0-2966 | Pressure controller P-gain 2 negative |

With the extended pressure controller, an inflected characteristic curve for the P-gain is activated. Through targeted gain, optimum controlling can be achieved. As can be seen in the figure below, the second P-gain becomes effective only above the threshold to be set.

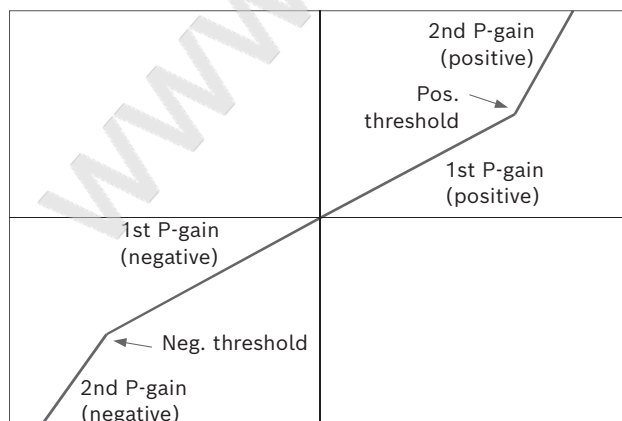

Fig. 28: Second P-gain

8.1.8.3 D-component

Table 18: D-component

| Parameter | Designation |
|-----------|---|
| P-0-2969 | Pressure controller time constant D-component positive |
| P-0-2970 | Pressure controller time constant D-component negative |
| P-0-2971 | Pressure controller time constant swivel angle feedback |
| P-0-2978 | Swivel angle controller time constant D-component |

The D-component scales the change of the actual value signal and ensures a damped transient response of the pressure or swivel angle controller. Differentiation results in a very high sensitivity, which responds also to undesirable signals such as interference and can make the system unstable. In the case of a constant actual value, the D-component does not respond, since the change rate is zero.

The higher the D-component, the slower is the system’s response. However, values that are too small cause instability due to the gain of disturbances in the actual pressure value signal.

8.1.8.4 Set the pressure controller PD-gain

The PD-gain corresponds to the summation of the P-gain and D-components mentioned before, as described in chapter 5.3.1 “Structure of the control” on page 21.

The values of the PD parameters to be set (P-0-2963, P-0-2964, P-0-2969, P-0-2970) vary depending on the application at hand. In general, it is valid that higher values lead to a faster responding control. However, an excessive increase leads to unstable characteristics, since the actual value that is fed back is continuously increasing or decreasing (oscillation). The optimum value of the entire control gain is a compromise between balancing characteristics and stability.

Notes on the setting of the individual parameters are given in the following:

Example 1

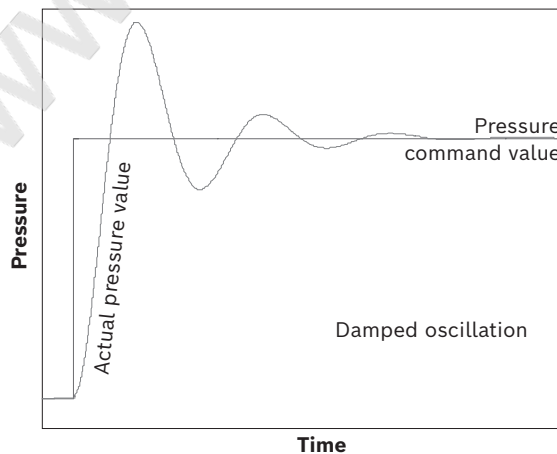

Fig. 29: Damped oscillation

Table 19: Setting of damped oscillation

| Step | Behavior/result | Action |
|------|--|----------------------|
| 1 | Overshoots (damped oscillation) | Increase D-component |
| 2 | Actual pressure value still overshooting | Reduce P-gain |

Example 2

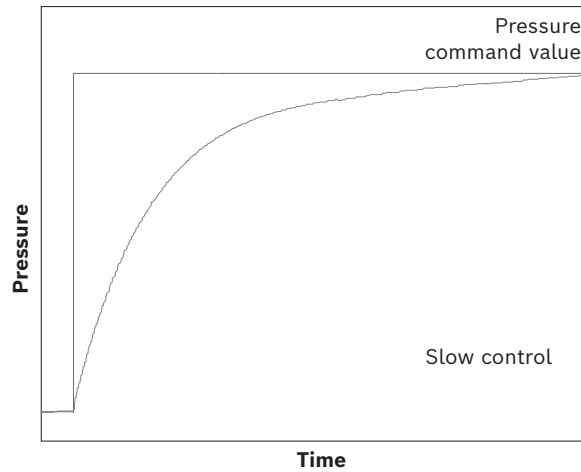

Fig. 30: Slow control

Table 20: Slow control

| Step | Behavior/result | Action |
|------|---------------------|--------------------|
| 1 | Slow reaction | Increase P-gain |
| 2 | Reaction still slow | Reduce D-component |

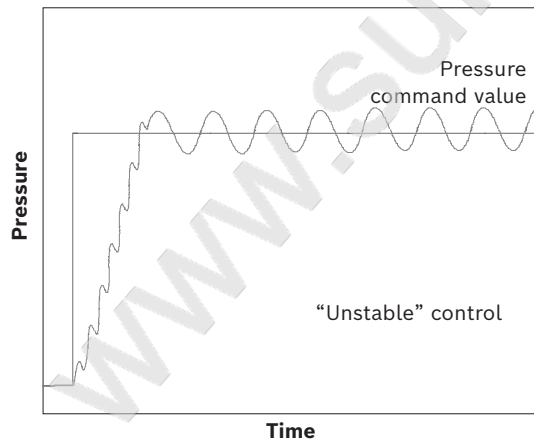

Fig. 31: Unstable control

Table 21: Steps in the case of fast, but unstable reaction

| Step | Behavior/result | Action |
|------|-----------------------------|--------------------|
| 1 | Fast, but unstable reaction | Reduce P-gain |
| 2 | | Reduce D-component |

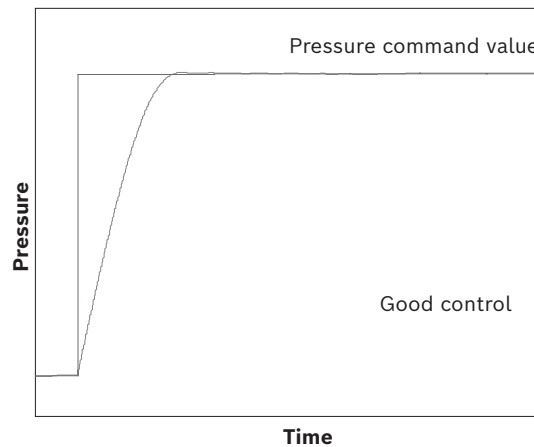

Fig. 32: Good control

If the control behavior is good, no measures need to be taken.



When the drive speed is changed, the pressure controller has to be adjusted as well. For further information on this adjustment, see RE 30237-Z.

Gate time

The gate time exclusively influences the D-component and reduces the sensitivity to disturbances. These parameters are used to set the number of actual values to be acquired. It must be noted that an increase in the gate time means a time delay of the averaged actual value, which may, under certain circumstances, result in phase shifting and thus in instability. Moreover, the gate time should be a multiple of the pump pulsation (225 Hz at 1500 rpm), i.e. for

- 50-Hz machines → gate time 4.4 ms / 8.9 ms / ... / 22.2 ms / ...
- 60-Hz machines → gate time 3.7 ms / 7.4 ms / ... / 22.2 ms / ...

Table 22: Gate time

| Parameter | Designation |
|-----------|--|
| P-0-2960 | Gate time derivation actual pressure value 1 |
| P-0-2979 | Gate time derivation actual pressure value 2 |

8.1.8.5 Select the active actual pressure value

Table 23: Selection of the active actual pressure value

| Parameter | Designation |
|-----------|------------------------------|
| P-0-2950 | Pump controller control word |

For some applications it may be advantageous to be able to switch between two pressure transducers. This changeover can be carried out with the help of the pump controller control word (P-0-2950, bit 8) and in IndraWorks in the dialog "Actual pressure value acquisition". With the factory setting, pressure feedback value "1" is activated.

8.1.8.6 Feedback of actual pressure derivative

Table 24: Feedback of actual pressure derivative

| Parameter | Designation |
|-----------|--|
| P-0-2973 | Filter time for feedback of actual pressure value derivative |
| P-0-2974 | Time constant for feedback of actual pressure value derivative |

In the case of low-frequency systems, e.g. cylinders with long strokes or large moved masses, poorly damped vibrations can occur in SWA control. By feeding back the derivative of pressure this vibration can be actively dampened. To this end, the derivative of pressure with negative sign is added to the swivel angle command value. For the derivation of pressure the gate time is used and the value is then filtered using P-0-2973.

In the condition as supplied, the feedback of the pressure derivative is set to the default value of 0, i.e. the function is disabled.

8.1.8.7 Feedforward control factor for slave

Table 25: Reducing the swivel angle difference between master and slave

| Parameter | Designation |
|-----------|---|
| P-0-2984 | Output adjustment, scaling feedforward positive |
| P-0-2985 | Output adjustment, scaling feedforward negative |

The displacement can be increased by coupling several SY(H)DFEx pumps. In order that this SY(H)DFEx system operates approximately synchronously, the valve command value of the master can be provided as feedforward value for the slaves. This reduces the swivel angle difference between master and slave.

Detailed information about the setup of master/slave operation can be found in chapter 5.9 "Master/slave operation" from page 33 onwards and the functional description "HydraulicDrive".

8.1.9 Calibrating the SY(H)DFED control system

With the help of regular calibration with the calibration functions of the SY(H)DFED control system, stable system characteristics can be achieved, because long-term drifts are compensated for.

For the calibration of the SYDFED control system we recommend the following order:

1. Calibration of pressure transducer
2. Calibration of valve
3. Calibration of swivel angle sensor offset
4. Calibration of swivel angle sensor gain
5. Calibration of leakage compensation

Further details on the configuration and activation of calibration functions can be found in the description of the HydraulicDrive firmware.

The individual calibration functions can be started via IndraWorks and the dialog "Pump controller calibration".

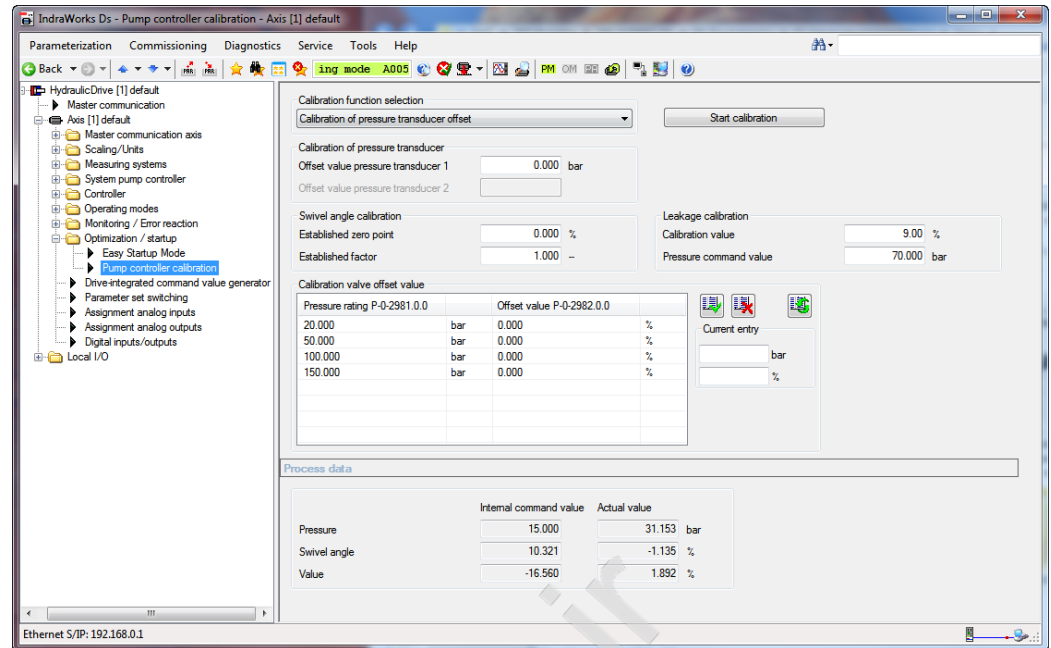

Fig. 33: Calibration



For calibrating the SY(H)DFED control system, the hydraulic fluid must have reached operating temperature.

8.2 RECOMMISSIONING AFTER STANDSTILL

Depending on the installation and ambient conditions, changes may occur in the system which make recommissioning necessary.

Among others, the following criteria may result in the necessity for recommissioning:

- Air in the hydraulic system
- Water in the hydraulic system
- Aged hydraulic fluid
- Other contamination

- ▶ For recommissioning, proceed as described in chapter 8.1 “Initial commissioning” on page 59.

8.3 RUNNING-IN PHASE

NOTICE

Viscosity too low!

Risk of damage! The increased temperature of the hydraulic fluid during the running-in phase can cause the viscosity to drop to impermissible levels.

- ▶ Monitor the operating temperature during the running-in phase.
- ▶ Reduce the loading (pressure, speed) of the SY(H)DFED control system, if impermissible operating temperatures and/or viscosities occur.

Bearings and sliding surfaces are subject to a running-in phase. Increased friction at the start of the running-in phase results in increased heat generation which decreases with increasing operating hours. The volumetric and mechanical-hydraulic efficiency rises as well by the end of the running-in phase of approx. 10 operating hours.



If HFC fluids are used, observe the notes on the running-in phase/ commissioning in RE 92053!

9 Operation

On the SY(H)DFED control system, no adjustments or modifications are required during operation. For this reason, this chapter of the manual does not contain any information on adjustment options. Only use the product within the performance range provided in the technical data. The machine or system manufacturer is responsible for the correct project planning of the hydraulic system and its control.

10 Maintenance and repair

10.1 CLEANING AND CARE

NOTICE

Solvents and aggressive cleaning agents!

Aggressive cleaning agents can damage the seals on the SY(H)DFED control system and make them age faster.

- ▶ Never use solvents or aggressive cleaning agents.

Ingress of dirt and liquids!

This will result in the fact that safe operation of the SY(H)DFED control system can no longer be ensured.

- ▶ When carrying out any work on the SY(H)DFED control system, observe strictest cleanliness.
- ▶ Do not use high-pressure cleaners.

For cleaning and care of the SY(H)DFED control system, observe the following:

- ▶ Plug all openings with suitable protective caps/devices.
- ▶ Check that all seals and plugs of the plug-in connections are securely seated to ensure that no moisture can enter the SY(H)DFED control system during cleaning.
- ▶ Use only water and, if necessary, a mild detergent to clean the SY(H)DFED control system.
- ▶ Remove external coarse dirt and keep sensitive and important parts like solenoids, valves and indicators clean.

10.2 INSPECTION

In order that the SY(H)DFED control system works reliably and for a long time, Rexroth recommends that you inspect the SY(H)DFED control system regularly at the following maintenance intervals and document the following operating conditions:

Table 26: Inspection schedule

| Work to be carried out | Interval | |
|------------------------|--|---|
| Hydraulic system | Check level of hydraulic fluid in the tank. | Daily |
| | Check operating temperature (comparable load state). | Weekly |
| | Analyze quality of the hydraulic fluid. | Annually or every 2000 h (whichever occurs first) |

| Work to be carried out | | Interval |
|--------------------------|---|----------|
| SY(H)DFED control system | Inspect the SY(H)DFED control system for leakage. The early detection of hydraulic fluid loss can help identify and rectify faults on the machine or system. For this reason, Rexroth recommends that the SY(H)DFED control system and the system as a whole always be kept in a clean condition. | Daily |
| | Check the SY(H)DFED control system for the generation of noise. | Daily |
| | Check mounting elements for proper fit. Inspect all mounting elements while the system is switched off, depressurized and cooled down. | Monthly |

10.3 MAINTENANCE

SY(H)DFED control systems require little maintenance when used as intended.

The service life of the SY(H)DFED control system is heavily dependent on the quality of the hydraulic fluid. For this reason, we recommend changing the hydraulic fluid at least once a year or every 2000 operating hours (whichever occurs first) or having it analyzed by the hydraulic fluid supplier or a laboratory to determine its suitability for further use.

The service life of the SY(H)DFED control system is limited by the service life of the built-in bearings. The service life can be requested on the basis of the load cycle from the responsible Rexroth Service partner, see chapter 10.5 “Spare parts” below. Based on these details, a maintenance interval is to be determined by the system manufacturer for the replacement of the bearings and included in the maintenance schedule of the hydraulic system.

If the firmware needs to be updated, see chapter 5.10.2 “Firmware update” on page 36.

10.4 REPAIR



Rexroth offers a comprehensive range of services for the repair of Rexroth SY(H)DFED control systems.

Repairs of the SY(H)DFED control system may only be performed by authorized, skilled and instructed staff.

- Use exclusively genuine spare parts from Rexroth for repairs of the Rexroth SY(H)DFED control system.

Partially tested and pre-assembled original Rexroth assemblies allow for successful repairs within a minimum of time.

10.5 SPARE PARTS

When ordering spare parts, please state the material number of the relevant spare parts. On some components, the material number is shown on a nameplate or a label.

Please address all questions regarding spare parts to your responsible Rexroth Service partner.

Bosch Rexroth AG
Service Industriehydraulik
Bürgermeister-Dr.-Nebel-Straße 8
97816 Lohr am Main
Germany

Phone +49 (0) 9352/40 50 60
E-mail service@boschrexroth.de

Outside Germany you will find service subsidiaries in your vicinity on the Internet at www.boschrexroth.com

- ▶ Please state the following data from the nameplate on your order:
 - Material number
 - Serial number
 - production job order number
 - Date of production

10.5.1 Replacement of components

The replacement of some components of the SY(H)DFED control system is described in the following.

Swivel angle sensor VT-SWA-...G15 for SYDFED systems

The operating principle of VT-SWA-...G15 swivel angle sensors, which work with a Hall sensor, is based on the evaluation of a magnetic field related to the rotary angle. The system operates contactless and is therefore wear-free.

In case that repairs have to be carried out on the swivel angle transducer of the SY(H)DFED system, observe the installation notes for the VT-SWA-...G15 swivel angle sensor and its magnet carrier.

The material number for the kit, magnet carrier and seals included, is R901396459.

General

The magnet carrier is a sensitive component and must therefore be handled with care. It must not be subjected to impacts and be kept away from magnetizable or magnetic parts! Until the carrier is installed in the pump housing, the original packaging is the safest place of storage.

Installing the magnet carrier

- ▶ Installation orientation with clockwise rotating pump:
The locating pin of the magnet carrier points towards the subplate of the pump (away from the drive motor). The bore for the locating pin is marked with a color point.
- ▶ Insert the magnet carrier in the receptacle provided in the housing of the A10 pump.

- ▶ A special tool (plastic mounting sleeve, material no. R900846331) is required for inserting and tightening the countersunk screw! If this mounting sleeve is not available, use a suitable tool made of non-magnetic material for inserting the mounting screw and for guiding a screw driver between the poles of the magnet.
- ▶ Tighten the countersunk screw M6 x 12 to 10.5 Nm.
After having installed the magnet carrier, check with your fingers, whether the magnets positively adhere to the carrier.

Installing the VT-SWA-...-G15 swivel angle sensor

- ▶ “Glue in” the O-ring of the kit in the groove using some grease.
- ▶ Tighten mounting screws M6 x 35 with washers to 15.5 Nm.
- ▶ Adjust the swivel angle sensor. Notes on the adjustment can be found in chapter 15.3.1 “Checking the swivel angle measurement” on page 86 and in the functional description of the firmware HydraulicDrive in the chapter “Pump controller calibration”.

Miscellaneous

- ▶ If the magnet carrier has to be removed, also use a suitable mounting sleeve for loosening the countersunk screw (see note on “Installing the magnet carrier” above).



If the swivel angle sensor fails, proper operation of the SY(H)DFED system is no longer possible.

Swivel angle sensor VT-SWA-LIN-...-G15 for SYHDFED systems

General

The prod is a sensitive component and must therefore be handled with care. In particular with regard to the magnetic properties, the prod must not be subjected to hard impacts and has to be kept away from metal parts! Until the carrier is installed in the pump housing, the original packaging is the safest place of storage.

Installing the VT-SWA-LIN-...-G15 swivel angle sensor

- ▶ Tighten sensor to 25 +5 Nm (27 mm A/F)
- ▶ Adjust the swivel angle sensor. Notes on the adjustment can be found in chapter 15.3.1 “Checking the swivel angle measurement” on page 86.

Seal kits for the pump

Stating the Mat. no. of the pump you can order seal kits, which are either tailored to certain individual components or offered as complete packages.

Pilot valve VT-DFPD-X-1X

The pilot valve is a component, which is sensitive to contamination. When replacing it, take care that no contaminants can enter fluid-carrying parts of the valve and the pump. To replace the pilot valve loosen the 4 screws at the recessed corners of the nameplate on the pilot valve. After the replacement, tighten the screws to a tightening torque of 9 Nm \pm 1.8 %. Newly installed valves with integrated electronics need to be adjusted:

If the parameter settings (R parameters) in the replaced valve differ from the factory setting, the settings have to be adjusted on the valve to be newly installed.

- ▶ Carry out a calibration as described in 8.1.9 “Calibrating the SY(H)DFED control system” on page 70.

Preload valve

To replace the pre-load valve, loosen the mounting screws and remove the pre-load valve.

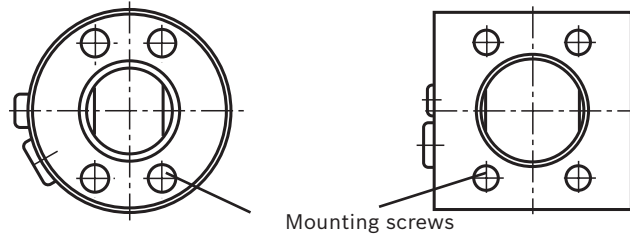

Fig. 34: Mounting bores: left-hand side (round) for NG 18, 28, 25; right-hand side (rectangular) for NG 71, 100, 140, 180

When mounting a new pre-load valve, take care that the seal on the pump side of the pre-load valve is positioned in the recess provided for this purpose. Tighten the mounting screws to the following torque:

| | |
|-------------------------|--------|
| Sizes 18, 28 and 45: | 45 Nm |
| Size 71: | 55 Nm |
| Sizes 100, 140 and 180: | 100 Nm |

After having mounted the pre-load valve, connect the high pressure and case drain oil pipes as described in chapter 7.3 “Installation positions and piping of SY(H)DFED systems” on page 43. During re-commissioning, bleed the pre-load valve. Notes on the bleeding procedure can be found in chapter 8.1.7 “Bleeding the pre-load valve” on page 65.

Pressure transducer HM20-X

Disconnect the electrical connection on the pilot valve. Replace the pressure transducer by turning out the existing pressure transducer and screwing in a new one. Tighten the pressure transducer to a torque of max. 20 - 25 Nm.

10.5.2 Test devices, assembly tools and note on commissioning

Test box for SYDFED

We offer a hand-held control box, designation “VT-PDFE-1-1X/V0/V0” (Mat. no. R900757051) for control systems SY(H)DFEE, SY(H)DFEC, SY(H)DFEn and SY(H)DFED for looping in into the existing cabling.

The hand-held control box requires a 24 V voltage supply from the customer side for the internal reference voltage and is equipped with:

- Command value potentiometer for swivel angle and pressure (analog inputs)
- Measuring points for all connection pins
- Additional supply option for a pressure transducer

Mounting tool for swivel angle transducer VT- SWA-1 (Hall sensor) for SYDFED-2X

The following fitting tool is available for the magnet carrier:

- For mounting: Plastic sleeve Mat. no. R900846331

11 Decommissioning

The SY(H)DFED control system is a component that does not require decommissioning. For this reason, this chapter of the present instructions does not contain any information. For details about how to demount or replace your SY(H)DFED control system, please refer to the following chapter 12 “Demounting and replacement”.

12 Demounting and replacement

12.1 REQUIRED TOOLS

The product can be demounted using standard tools. No special tools are necessary.

12.2 PREPARING DEMOUNTING

1. Decommission the entire system as described in the general instructions for the machine or system.
2. Depressurize the hydraulic system according to the instructions of the machine or system manufacturer.

12.3 DEMOUNTING

Proceed as follows to demount the SY(H)DFED control system:

1. Make sure that the hydraulic system is depressurized.
2. Check that the SY(H)DFED control system has cooled down sufficiently so that it can be removed without any risks.

NOTICE! Spilled or discharged hydraulic fluid!

Environmental damage and contamination of the groundwater!

- ▶ When filling in and changing the hydraulic fluid, always place a catch pan under the SY(H)DFED control system.
 - ▶ Observe the information in the safety data sheet for the hydraulic fluid and the instructions provided by the system manufacturer.
1. Loosen the lines and collect the escaping hydraulic fluid in the collector provided for this purpose.
 2. Demount the SY(H)DFED control system. Use suitable lifting gear for this.
 3. Drain the SY(H)DFED control system completely.
 4. Plug all openings.

12.4 PREPARING THE COMPONENTS FOR STORAGE OR FURTHER USE

- ▶ Proceed as described in chapter 6.2 “Storing the SY(H)DFED control system“ on page 40.

13 Disposal

13.1 ENVIRONMENTAL PROTECTION

Careless disposal of the hydraulic components and the hydraulic fluid can lead to pollution of the environment.

- ▶ Thus, dispose of the product and the hydraulic fluid in accordance with the national regulations in your country.
- ▶ Dispose of hydraulic fluid residues according to the applicable safety data sheets for these hydraulic fluids.
- ▶ Observe the following notes for an environmentally friendly disposal of the hydraulic component.

13.2 RETURN TO BOSCH REXROTH AG

The hydraulic products manufactured by us can be returned to us for disposal purposes at no costs. When returned, the products must not contain any inappropriate foreign substances or third-party components. Hydraulic valves have to be drained before being returned. The components have to be sent carriage paid to the following address:

Bosch Rexroth AG
Service Industriehydraulik
Bürgermeister-Dr.-Nebel-Straße 8
97816 Lohr am Main
Germany

13.3 PACKAGING

Upon request, reusable systems can be used for regular deliveries.

The materials for disposable packaging are mostly cardboard, wood, and expanded polystyrene. They can be recycled without any problems. For ecological reasons, disposable packaging should not be used for returning products to Bosch Rexroth.

13.4 MATERIALS USED

Hydraulic components from Bosch Rexroth do not contain any hazardous substances that could be released when used as intended. In the normal case, no negative effects on human beings and on the environment have to be expected.

The hydraulic valves basically consist of:

- Cast iron
- Steel
- Aluminum
- Copper
- Plastics
- Electronics components and assemblies
- Elastomers

13.5 RECYCLING

Due to the high metal share, hydraulic products can mostly be recycled. In order to achieve an ideal metal recovery, disassembly into individual assemblies is required. The metals contained in electrical and electronic assemblies can also be recovered by means of special separation procedures.

14 Extension and modification

The SY(H)DFED control system may only be converted or extended in the cases described below using genuine Rexroth SY(H)DFED components. Other conversions or extensions, also the readjustment of lead-sealed adjustment potentiometers, render the warranty void. The replacement of a component with a component of identical design is described in chapter 10.5 "Spare parts" on page 75.

The SY(H)DFED control system may be extended by adding an SYDZ pre-load valve. Please ensure that the size of the pre-load valve and the size of the pump are identical.

www.summy.it

15 Troubleshooting

The following table may assist you in troubleshooting. The table is not exhaustive. In practice, problems which are not listed here may also arise.

15.1 HOW TO PROCEED FOR TROUBLESHOOTING

- ▶ Always work systematically and purposefully, even when under time pressure. Random and imprudent disassembly and changing of settings can, in the worst-case scenario, result in the inability to determine the original cause of error.
- ▶ First obtain a general overview of how your product works in conjunction with the entire system.
- ▶ Try to find out whether the product has functioned properly in conjunction with the overall system before the fault occurred.
- ▶ Try to determine any changes of the overall system in which the product is integrated:
 - Were there any changes to the product's operating conditions or operating range?
 - Were there any changes (e.g. retrofit) or repairs carried out on the complete system (machine/system, electrics, control) or on the product? If yes: What were they?
 - Was the product or machine used as intended?
 - How did the fault become apparent?
- ▶ Try to get a clear idea of the error cause. If possible, ask the direct (machine) operator.
- ▶ If you cannot rectify the error, contact one of the contact addresses which can be found at:
www.boschrexroth.com/addresses

15.2 ERROR/DIAGNOSTIC MEMORY

For diagnosis purposes, the SY(H)DFED control system is fitted with an internal error and diagnostic message memory. To open the error memory, select **“Diagnostics”** → **“Error/diagnostic memory”**.

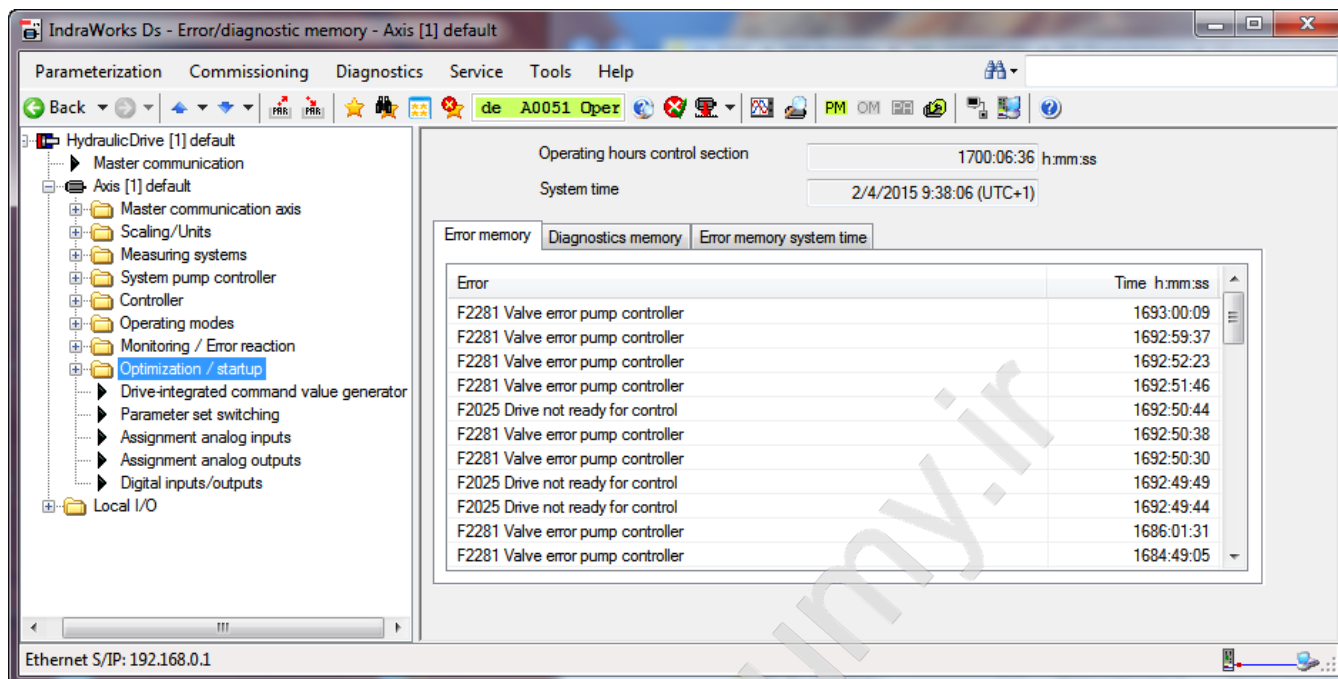

Fig. 35: Error/diagnostic memory

15.2.1 Error diagnosis

At pin 3 of the central connector the signal “drive ready” can be output. For this, the factory assignment of the digital output to parameter P-0-0115, bit 1, must be activated. This signal can be used to find out whether the control is active and that no error message is present. Should an error message occur during operation or the controller enable be withdrawn, this bit is set to 0.

Here, the following is valid:

Table 27: Messages

| Meaning of the message | Output signal at pin 3 |
|---|------------------------|
| Electronics OK | 24 V |
| Error message present or no controller enable set | 0 V |

15.3 FAULT TABLE

Table 28: Fault table of SY(H)DFED control systems

| Malfunction | Possible cause | Remedy |
|--|---|---|
| Message “analog input, wire break” at actual pressure value input | Actual pressure value of the relevant pressure transducer fell below or exceeded the limit value, that is, the value is outside the permissible measuring range of the A/D converter. | Test actual pressure value signal (wire rupture, working range, signal type, polarity) |
| Message “Wire rupture of swivel angle sensor” | Defective swivel angle sensor cable (visual inspection) | Replace swivel angle sensor |
| | Defective swivel angle sensor | Replace swivel angle sensor |
| | Internal electronics fault | Have the pilot valve repaired by Rexroth Service or replace pilot valve |
| Message “Valve error pump controller” (deviation between command and actual position of the valve spool) | Valve spool jams due to contamination | Replace pilot valve (see page 76), contact Rexroth Service |
| | Internal electronics fault | Replace pilot valve, see page 76 |
| Message “Control deviation pump controller” | Backpressure cannot be built up (minimum pressure at the pump 8...10 bar) | Check that the hydraulic system is leak-free and there is no excessive oil consumption |
| | Drive motor switched off or speed too low | Check electrical control and motor control |
| | Valve spool does not move as a result of electronics fault | Replace pilot valve, see page 76 |
| | Valve spool jams due to contamination | Replace pilot valve (see page 76), contact Rexroth Service |
| Humming noise in the pressure control or fluctuations in pressure/flow | Air cushion around the sensor | Bleed control system, pre-load valve (see chapter 8.1.7 on page 65) and pipes completely |
| | Problem with the cable shield | Connect shield to ground |
| | Incorrect protective earth connection in the control cabinet | Properly connect protective earth connector |
| | No connection from M0 to L0 | Connect M0 (XH4, pin 4) and L0 (XH4, pin 2) in the control cabinet |
| | Unfavorable place of installation/mounting technique for the pressure transducer | Change place of installation (e.g. suspended mounting, no minimum line, no throttling point between pump and pressure transducer), see page 57. |
| | Improperly high gain of the actual pressure value | Reduce P-gain, see chapter 8.1.8.1 on page 66 |
| Screaming noise | Oil level in the tank too low; pump partly aspires air | Top up oil |
| | Pump aspires air | Change routing of the suction line |
| | Suction line leaky | Seal suction line |
| | Pump cavitates when pressure is reduced Diagnostics: Measure, whether the pressure in the pressure line overshoots | Optimize controller, reduce the command value via a ramp or in steps |
| | Fluid in the tank mixed with air; cooling and/or filtration circuit leaky | Seal |

Table 28: Fault table of SY(H)DFED control systems

| Malfunction | Possible cause | Remedy | |
|--|---|--|---|
| Other unusual noise | Input speed too high | Machine or system manufacturer | |
| | Wrong direction of rotation | Machine or system manufacturer | |
| | Insufficient suction conditions, e.g. air in the suction line, insufficient diameter of the suction line, viscosity of the hydraulic fluid too high, suction height too great, suction pressure too low, foreign body in the suction line | | Check, whether shut-off valves are open |
| | | | Machine or system manufacturer (e.g. optimize inlet conditions, use suitable hydraulic fluid) |
| | | | Air-bleed control system completely, fill suction line with hydraulic fluid |
| | | Remove foreign particles from the suction line | |
| | Improper mounting of the control system | Check mounting of the control system according to the instructions given by the machine or system manufacturer. Observe tightening torques | |
| Improper mounting of attachment parts, e.g. coupling and hydraulic lines | Mount attachments in accordance with the instructions of the coupling or fitting manufacturer | | |
| Air in the pump or in the pre-load valve | Bleed pump and pre-load valve | | |
| Wear/mechanical damage to the control system | Replace control system, contact Rexroth Service | | |
| No or insufficient pressure (< 4 bar) | Faulty mechanical drive (e.g. defective coupling) | Machine or system manufacturer | |
| | Hydraulic fluid not within the optimum viscosity range | Use suitable hydraulic fluid (machine or system manufacturer) | |
| | Drive unit defective (e.g. hydraulic motor or cylinder) | Machine or system manufacturer | |
| | Wear/mechanical damage | Replace control system, contact Rexroth Service | |
| Pressure fixed, ca. 5...12 bar, cannot be changed | Supply voltage not within the permissible range Diagnostics: Check status LEDs | Check, whether central plug XH4 is connected to the pilot valve | |
| | | Check voltage at the last interconnection point (terminal strip) upstream of the pilot valve | |
| | Command value for pressure, swivel angle or power (optional) is 0 bar or 0 %, respectively | If you use, for example, exclusively closed-loop pressure control, provide a swivel angle command value of 100 % | |
| | Swivel angle sensor defective | Check swivel angle measurement, see 15.3.1 on page 86 | |
| | Spool jams in pilot valve | Contact Rexroth Service | |

Table 28: Fault table of SY(H)DFED control systems

| Malfunction | Possible cause | Remedy |
|---|--|---|
| Pressure too low | Actual pressure value acquisition incorrectly configured | Check actual pressure value in IndraWorks and, if required, correct configuration of actual pressure value acquisition |
| | | Replace pressure transducer, see page 77 |
| | | Change the place of installation of the pressure transducer (do not install upstream of the pre-load valve; where appropriate, close to the consumer) |
| | Pressure transducer defective/not connected Diagnostics: Measure signal from PT and compare with indication on the pressure gauge | Replace pressure transducer, see page 77 |
| Pressure too high | Control system does not work in closed-loop pressure control | Increase swivel angle command value Check that the hydraulic system is leak-free and there is no excessive oil consumption |
| | Pilot valve defective | Replace pilot valve, see page 76 |
| | Actual pressure value acquisition incorrectly configured | Check actual pressure value in IndraWorks and, if required, correct configuration of actual pressure value acquisition |
| Insufficient flow | Pressure transducer defective/not connected Diagnostics: Measure signal from PT and compare with indication on the pressure gauge | Replace pressure transducer, see page 77 |
| | Pilot valve defective | Replace pilot valve, see page 76 |
| | Pressure controller active | Increase pressure command value |
| | Actual swivel angle acquisition improperly set | Recalibrate swivel angle sensor |
| Drive motor shuts down due to overloading | Drive speed too low (slip, incorrect frequency, wrong motor) | Contact machine or system manufacturer |
| | Damage to the pump (excessive pump leakage) | Rotary group damaged Contact Rexroth Service |
| | Wear/mechanical damage to the control system | Replace control system, contact Rexroth Service |
| | Excessive power consumption of the pump | Reduce torque limit Reduce swivel angle command value Check actual pressure value acquisition |
| | Overcurrent protection of motor does not work properly | Check setting and function |
| | Spool jams in pilot valve Diagnostics: Compare actual value and valve command value in IndraWorks | Replace pilot valve, see page 76 |
| Actual swivel angle value acquisition maladjusted or not working properly | Swivel angle measurement check, see page | |
| Valve electronics defective | Replace pilot valve, see page 76 | |

Table 28: Fault table of SY(H)DFED control systems

| Malfunction | Possible cause | Remedy |
|--------------------------------------|---|---|
| Hydraulic fluid temperature too high | Inlet temperature at control system too high | Inspect system, e.g. for malfunction of the cooler, insufficient hydraulic fluid in the tank |
| | DB in pre-load valve opens Diagnosis: Pipe to the tank heats up | Pressure must be lower than the cracking pressure of the pre-load valve. Keep overshoots and pressure pulsation to a minimum. |
| | Malfunction of pressure control valves (e.g. high pressure relief valve, pressure cut-off valve, pressure controller) | Contact Rexroth Service |
| | Control system worn out | Replace control system, contact Rexroth Service |

15.3.1 Swivel angle measurement check

The settings for swivel angle measurement are made in the factory. The settings described below must only be made after a replacement of the swivel angle transducer.

Depending on circumstances, a calibration of the swivel angle "100 %" can be conducted while the drive motor is running or at rest.

15.3.1.1 Checking swivel angle "zero" (while system is running)

1. Close all directional valves
2. Apply a swivel angle command value of >50 %
3. Apply a pressure command value of 20 bar
4. Check, whether the actual swivel angle value (α_{act}) is $0 \text{ V} \pm 1 \text{ mV}$ The resulting actual pressure value must be ca. 20 bar.
5. In case of deviations start the calibration of the swivel angle sensor zero point.

15.3.1.2 Checking swivel angle "100%" (while system is running)

1. Apply a pressure command value of 100 bar, activate pressure controller only in changeover logic
2. Direct the full flow via the actuator, e.g. activate hydraulic motor or set pressure relief valve to ca. 20 bar; in this case, the pilot valve deliberately signals a warning (excessive control deviation)
3. Check, whether the actual swivel angle value (α_{act}) is $100 \% \pm 1 \%$ In the case of deviations start the calibration of the swivel angle sensor factor.

15.3.1.3 Checking swivel angle "100%" (while drive motor is switched off)

1. Switch the hydraulic system off and wait for ca. 5 min until the pump has swiveled out mechanically (wait until pressure reduction is completed).
2. Check, whether the actual swivel angle value (α_{act}) is $100 \% \pm 1 \%$ In the case of deviations, observe point 3.

3. In some cases, the pump will not swivel out to the positive stop. For this reason, switch the motor on briefly, then switch off, wait until the pump has swiveled out and check the actual swivel angle value. If the actual swivel angle value of 100 % \pm 1 % cannot be reached, switch on drive motor and start calibration of swivel angle sensor factor.

16 Technical data

The technical data of your SY(H)DFED system are contained in the following data sheets:

| | |
|-------------------|----------|
| SYDFED series 2X | RE 30030 |
| SYDFED series 3X | RE 30630 |
| SYHDFED series 1X | RE 30035 |

You can find the data sheets on the Internet at

www.boschrexroth.com/ics

The pre-set technical data of your SY(H)DFED control system are listed in the order confirmation.

Further descriptions and information as well as the engineering tool IndraWorks can be found on the Rexroth website in the product portal "SY(H)DFED":

<https://www.boschrexroth.com/sydfe>

<https://www.boschrexroth.de/indraworks>

17 Annex

17.1 LIST OF ADDRESSES

Contact for service and spare parts

Bosch Rexroth AG
Service Industriehydraulik
Bürgermeister-Dr.-Nebel-Straße 8
97816 Lohr am Main
Germany

Phone +49 (0) 9352/40 50 60
E-mail service@boschrexroth.de

Support

Email support.automation@boschrexroth.de

Outside Germany you will find service subsidiaries in your vicinity on the Internet at www.boschrexroth.com

Headquarters

Bosch Rexroth AG
Zum Eisengiesser 1
97816 Lohr am Main
Germany

Phone +49 (0) 9352/18-0
Email my.support@boschrexroth.com

The addresses of our sales and service network and sales organizations can be found at www.boschrexroth.com/addresses

17.2 OPEN SOURCE SOFTWARE

HydraulicDrive devices use 3rd party software components.

| Software component | Firmware derivative FWA-HYDRV | | | | |
|-----------------------------|-------------------------------|----------|----------|----------|----------|
| | -HDB-... | -HDC-... | -HDE-... | -HDM-... | -HDP-... |
| ZLIB | | ● | | ● | ● |
| pstdint.h | | ● | | ● | ● |
| XZ Embedded | | | ● | | |
| Aaron Gifford's SHA-2 | | ● | | | |
| Freescale Semiconductor SDK | ● | ● | ● | ● | ● |
| Newlib | ● | ● | ● | ● | ● |
| lwIP – TCP/IP stack | ● | ● | ● | ● | ● |
| lwIP – SNMP agent | ● | ● | ● | ● | x |

These 3rd party software components are subject to the following license terms.

ZLIB, DATA COMPRESSION LIBRARY, version 1.2.5:

(C) 1995-2010 Jean-loup Gailly and Mark Adler

This software is provided "as-is", without any express or implied warranty. In no event will the authors be held liable for any damages arising from the use of this software.

Permission is granted to anyone to use this software for any purpose, including commercial applications, and to alter it and redistribute it freely, subject to the following restrictions:

1. The origin of this software must not be misrepresented; you must not claim that you wrote the original software. If you use this software in a product, an acknowledgment in the product documentation would be appreciated but is not required.

2. Altered source versions must be plainly marked as such, and must not be misrepresented as being the original software.

3. This notice may not be removed or altered from any source distribution.

Jean-loup Gailly Mark Adler
jloup@gzip.org madler@alumni.caltech.edu

If you use the zlib library in a product, we would appreciate "not" receiving lengthy legal documents to sign. The sources are provided for free but without warranty of any kind. The library has been entirely written by Jean-loup Gailly and Mark Adler; it does not include third-party code. If you redistribute modified sources, we would appreciate that you include in the file ChangeLog history information documenting your changes. Please read the FAQ for more information on the distribution of modified source versions.

pstdint.h, version 0.1.12

Copyright (c) 2005-2011 Paul Hsieh
All rights reserved.

Redistribution and use in source and binary forms, with or without modification, are permitted provided that the following conditions are met:

1. Redistributions of source code must retain the above copyright notice, this list of conditions and the following disclaimer.
2. Redistributions in binary form must reproduce the above copyright notice, this list of conditions and the following disclaimer in the documentation and/or other materials provided with the distribution.
3. The name of the author may not be used to endorse or promote products derived from this software without specific prior written permission.

THIS SOFTWARE IS PROVIDED BY THE AUTHOR "AS IS" AND ANY EXPRESS OR IMPLIED WARRANTIES, INCLUDING, BUT NOT LIMITED TO, THE IMPLIED WARRANTIES OF MERCHANTABILITY AND FITNESS FOR A PARTICULAR PURPOSE ARE DISCLAIMED. IN NO EVENT SHALL THE AUTHOR BE LIABLE FOR ANY DIRECT, INDIRECT, INCIDENTAL, SPECIAL, EXEMPLARY, OR CONSEQUENTIAL DAMAGES (INCLUDING, BUT NOT LIMITED TO, PROCUREMENT OF SUBSTITUTE GOODS OR SERVICES; LOSS OF USE, DATA, OR PROFITS; OR BUSINESS INTERRUPTION) HOWEVER CAUSED AND ON ANY THEORY OF LIABILITY, WHETHER IN CONTRACT, STRICT LIABILITY, OR TORT (INCLUDING NEGLIGENCE OR OTHERWISE) ARISING IN ANY WAY OUT OF THE USE OF THIS SOFTWARE, EVEN IF ADVISED OF THE POSSIBILITY OF SUCH DAMAGE.

XZ Embedded, version 15.03.2013

All the files in this package have been written by Lasse Collin and/or Igor Pavlov. All these files have been put into the public domain. You can do whatever you want with these files. As usual, this software is provided "as is", without any warranty.

Aaron Gifford's SHA-2 version 1.0.1

Copyright (c) 2000-2001, Aaron D. Gifford
All rights reserved.

Redistribution and use in source and binary forms, with or without modification, are permitted provided that the following conditions are met:

1. Redistributions of source code must retain the above copyright notice, this list of conditions and the following disclaimer.
2. Redistributions in binary form must reproduce the above copyright notice, this list of conditions and the following disclaimer in the documentation and/or other materials provided with the distribution.
3. Neither the name of the copyright holder nor the names of contributors may be used to endorse or promote products derived from this software without specific prior written permission.

THIS SOFTWARE IS PROVIDED BY THE AUTHOR AND CONTRIBUTOR(S) "AS IS" AND ANY EXPRESS OR IMPLIED WARRANTIES, INCLUDING, BUT NOT LIMITED TO, THE IMPLIED WARRANTIES OF MERCHANTABILITY AND FITNESS FOR A PARTICULAR PURPOSE ARE DISCLAIMED. IN NO EVENT SHALL THE AUTHOR OR CONTRIBUTOR(S) BE LIABLE FOR ANY DIRECT, INDIRECT, INCIDENTAL, SPECIAL, EXEMPLARY, OR CONSEQUENTIAL DAMAGES (INCLUDING,

BUT NOT LIMITED TO, PROCUREMENT OF SUBSTITUTE GOODS OR SERVICES; LOSS OF USE, DATA, OR PROFITS; OR BUSINESS INTERRUPTION) HOWEVER CAUSED AND ON ANY THEORY OF LIABILITY, WHETHER IN CONTRACT, STRICT LIABILITY, OR TORT (INCLUDING NEGLIGENCE OR OTHERWISE) ARISING IN ANY WAY OUT OF THE USE OF THIS SOFTWARE, EVEN IF ADVISED OF THE POSSIBILITY OF SUCH DAMAGE.

Freescale Semiconductor SDK

Copyright: Freescale Semiconductor, Inc. All Rights Reserved.

You are hereby granted a copyright license to use, modify, and distribute the SOFTWARE so long as this entire notice is retained without alteration in any modified and/or redistributed versions, and that such modified versions are clearly identified as such. No licenses are granted by implication, estoppel or otherwise under any patents or trademarks of Freescale Semiconductor, Inc. This software is provided on an "AS IS" basis and without warranty.

To the maximum extent permitted by applicable law, Freescale Semiconductor DISCLAIMS ALL WARRANTIES WHETHER EXPRESS OR IMPLIED, INCLUDING IMPLIED WARRANTIES OF MERCHANTABILITY OR FITNESS FOR A PARTICULAR PURPOSE AND ANY WARRANTY AGAINST INFRINGEMENT WITH REGARD TO THE SOFTWARE (INCLUDING ANY MODIFIED VERSIONS THEREOF) AND ANY ACCOMPANYING WRITTEN MATERIALS.

To the maximum extent permitted by applicable law, IN NO EVENT SHALL Freescale Semiconductor BE LIABLE FOR ANY DAMAGES WHATSOEVER (INCLUDING WITHOUT LIMITATION, DAMAGES FOR LOSS OF BUSINESS PROFITS, BUSINESS INTERRUPTION, LOSS OF BUSINESS INFORMATION, OR OTHER PECUNIARY LOSS) ARISING OF THE USE OR INABILITY TO USE THE SOFTWARE.

Freescale Semiconductor assumes no responsibility for the maintenance and support of this software.

Newlib 2.1.0

Red Hat Incorporated

Copyright (c) 1994-2009 Red Hat, Inc. All rights reserved.

This copyrighted material is made available to anyone wishing to use, modify, copy, or redistribute it subject to the terms and conditions of the BSD License. This program is distributed in the hope that it will be useful, but WITHOUT ANY WARRANTY expressed or

implied, including the implied warranties of MERCHANTABILITY or FITNESS FOR A PARTICULAR PURPOSE. A copy of this license is available at <http://www.opensource.org/licenses>. Any Red Hat trademarks that are incorporated in the source code or documentation are not subject to the BSD License and may only be used or replicated with the express permission of Red Hat, Inc.

University of California, Berkeley

Copyright (c) 1981-2000 The Regents of the University of California. All rights reserved.

Redistribution and use in source and binary forms, with or without modification, are permitted provided that the following conditions are met:

- * Redistributions of source code must retain the above copyright notice, this list of conditions and the following disclaimer.

- * Redistributions in binary form must reproduce the above copyright notice, this list of conditions and the following disclaimer in the documentation and/or other materials provided with the distribution.

- * Neither the name of the University nor the names of its contributors may be used to endorse or promote products derived from this software without specific prior written permission.

THIS SOFTWARE IS PROVIDED BY THE COPYRIGHT HOLDERS AND CONTRIBUTORS "AS IS" AND ANY EXPRESS OR IMPLIED WARRANTIES, INCLUDING, BUT NOT LIMITED TO, THE IMPLIED WARRANTIES OF MERCHANTABILITY AND FITNESS FOR A PARTICULAR PURPOSE ARE DISCLAIMED. IN NO EVENT SHALL THE COPYRIGHT OWNER OR CONTRIBUTORS BE LIABLE FOR ANY DIRECT, INDIRECT, INCIDENTAL, SPECIAL, EXEMPLARY, OR CONSEQUENTIAL DAMAGES (INCLUDING, BUT NOT LIMITED TO, PROCUREMENT OF SUBSTITUTE GOODS OR SERVICES; LOSS OF USE, DATA, OR PROFITS; OR BUSINESS INTERRUPTION) HOWEVER CAUSED AND ON ANY THEORY OF LIABILITY, WHETHER IN CONTRACT, STRICT LIABILITY, OR TORT (INCLUDING NEGLIGENCE OR OTHERWISE) ARISING IN ANY WAY OUT OF THE USE OF THIS SOFTWARE, EVEN IF ADVISED OF THE POSSIBILITY OF SUCH DAMAGE.

David M. Gay (AT&T 1991, Lucent 1998)

The author of this software is David M. Gay.

Copyright (c) 1991 by AT&T.

Permission to use, copy, modify, and distribute this software for any purpose without fee is hereby granted, provided that this entire notice is included in all copies of any software which is or includes a copy or modification of this soft-ware and in all copies of the supporting documentation for such software.

THIS SOFTWARE IS BEING PROVIDED "AS IS", WITHOUT ANY EXPRESS OR IMPLIED WARRANTY. IN PARTICULAR, NEITHER THE AUTHOR NOR AT&T MAKES ANY REPRESENTATION OR WARRANTY OF ANY KIND CONCERNING THE MERCHANTABILITY OF THIS SOFTWARE OR ITS FITNESS FOR ANY PARTICULAR PURPOSE.

The author of this software is David M. Gay.

Copyright (C) 1998-2001 by Lucent Technologies. All Rights Reserved

Permission to use, copy, modify, and distribute this software and its documentation for any purpose and without fee is hereby granted, provided that the above copyright notice appear in all copies and that both the copyright notice and this permission notice and warranty disclaimer appear in supporting documentation, and that the name of Lucent or any of its entities not be used

in advertising or publicity pertaining to distribution of the software without specific, written prior permission.

LUCENT DISCLAIMS ALL WARRANTIES WITH REGARD TO THIS SOFTWARE, INCLUDING ALL IMPLIED WARRANTIES OF MERCHANTABILITY AND FITNESS. IN NO EVENT SHALL LUCENT OR ANY OF ITS ENTITIES BE LIABLE FOR ANY SPECIAL, INDIRECT OR CONSEQUENTIAL DAMAGES OR ANY DAMAGES WHATSOEVER RESULTING FROM LOSS OF USE, DATA OR PROFITS, WHETHER IN AN ACTION OF CONTRACT, NEGLIGENCE OR OTHER TORTIOUS ACTION, ARISING OUT OF OR IN CONNECTION WITH THE USE OR PERFORMANCE OF THIS SOFTWARE.

Advanced Micro Devices

Copyright 1989, 1990 Advanced Micro Devices, Inc.

This software is the property of Advanced Micro Devices, Inc. (AMD) which specifically grants the user the right to modify, use and distribute this software provided this notice is not removed or altered. All other rights are reserved by AMD.

AMD MAKES NO WARRANTY OF ANY KIND, EXPRESS OR IMPLIED, WITH REGARD TO THIS SOFTWARE. IN NO EVENT SHALL AMD BE LIABLE FOR INCIDENTAL OR CONSEQUENTIAL DAMAGES IN CONNECTION WITH OR ARISING FROM THE FURNISHING, PERFORMANCE, OR USE OF THIS SOFTWARE.

So that all may benefit from your experience, please report any problems or suggestions about this software to the 29K Technical Support Center at 800-29-29-AMD (800-292-9263) in the USA, or 0800-89-1131 in the UK, or 0031-11-1129 in Japan, toll free. The direct dial number is 512-462-4118.

Advanced Micro Devices, Inc.

29K Support Products

Mail Stop 573

5900 E. Ben White Blvd.

Austin, TX 78741

800-292-9263

Sun Microsystems

Copyright (C) 1993 by Sun Microsystems, Inc. All rights reserved.

Developed at SunPro, a Sun Microsystems, Inc. business.

Permission to use, copy, modify, and distribute this software is freely granted, provided that this notice is preserved.

Hewlett Packard

(c) Copyright 1986 HEWLETT-PACKARD COMPANY

To anyone who acknowledges that this file is provided "AS IS" without any express or implied warranty: permission to use, copy, modify, and distribute this file for any purpose is hereby granted without fee, provided that the above copyright notice and this notice appears in all copies, and that the name of Hewlett-Packard Company not be used in advertising or publicity pertaining to distribution of the software without specific, written prior permission.

Hewlett-Packard Company makes no representations about the suitability of this software for any purpose.

Hans-Peter Nilsson

Copyright (C) 2001 Hans-Peter Nilsson

Permission to use, copy, modify, and distribute this software is freely granted, provided that the above copyright notice, this notice and the following disclaimer are preserved with no changes.

THIS SOFTWARE IS PROVIDED "AS IS" AND WITHOUT ANY EXPRESS OR IMPLIED WARRANTIES, INCLUDING, WITHOUT LIMITATION, THE IMPLIED WARRANTIES OF MERCHANTABILITY AND FITNESS FOR A PARTICULAR PURPOSE.

Christopher G. Demetriou

Copyright (c) 2001 Christopher G.

Demetriou. All rights reserved.

Redistribution and use in source and binary forms, with or without modification, are permitted provided that the following conditions are met:

1. Redistributions of source code must retain the above copyright notice, this list of conditions and the following disclaimer.
2. Redistributions in binary form must reproduce the above copyright notice, this list of conditions and the following disclaimer in the documentation and/or other materials provided with the distribution.
3. The name of the author may not be used to endorse or promote products derived from this software without specific prior written permission.

THIS SOFTWARE IS PROVIDED BY THE AUTHOR "AS IS" AND ANY EXPRESS OR IMPLIED WARRANTIES, INCLUDING, BUT NOT LIMITED TO, THE IMPLIED WARRANTIES OF MERCHANTABILITY AND FITNESS FOR A PARTICULAR PURPOSE ARE DISCLAIMED. IN NO EVENT SHALL THE AUTHOR BE LIABLE FOR ANY DIRECT, INDIRECT, INCIDENTAL, SPECIAL, EXEMPLARY, OR CONSEQUENTIAL DAMAGES (INCLUDING, BUT NOT LIMITED TO, PROCUREMENT OF SUBSTITUTE GOODS OR SERVICES; LOSS OF USE, DATA, OR PROFITS; OR BUSINESS INTERRUPTION) HOWEVER CAUSED AND ON ANY THEORY OF LIABILITY, WHETHER IN CONTRACT, STRICT LIABILITY, OR TORT (INCLUDING NEGLIGENCE OR OTHERWISE) ARISING IN ANY WAY OUT OF THE USE OF THIS SOFTWARE, EVEN IF ADVISED OF THE POSSIBILITY OF SUCH DAMAGE.

SuperH, Inc.

Copyright 2002 SuperH, Inc. All rights reserved

This software is the property of SuperH, Inc (SuperH) which specifically grants the user the right to modify, use and distribute this software provided this notice is not removed or altered. All other rights are reserved by SuperH.

SUPERH MAKES NO WARRANTY OF ANY KIND, EXPRESS OR IMPLIED, WITH REGARD TO THIS SOFTWARE. IN NO EVENT SHALL SUPERH BE LIABLE FOR INDIRECT, SPECIAL, INCIDENTAL OR CONSEQUENTIAL DAMAGES IN CONNECTION WITH OR ARISING FROM THE FURNISHING, PERFORMANCE, OR USE OF THIS SOFTWARE.

So that all may benefit from your experience, please report any problems or suggestions about this software to the SuperH Support Center via e-mail at softwaresupport@superh.com.

SuperH, Inc.
405 River Oaks Parkway
San Jose
CA 95134, USA

Royal Institute of Technology

Copyright (c) 1999 Kungliga Tekniska Högskolan (Royal Institute of Technology, Stockholm, Sweden). All rights reserved.

Redistribution and use in source and binary forms, with or without modification, are permitted provided that the following conditions are met:

1. Redistributions of source code must retain the above copyright notice, this list of conditions and the following disclaimer.
2. Redistributions in binary form must reproduce the above copyright notice, this list of conditions and the following disclaimer in the documentation and/or other materials provided with the distribution.
3. Neither the name of KTH nor the names of its contributors may be used to endorse or promote products derived from this software without specific prior written permission.

THIS SOFTWARE IS PROVIDED BY KTH AND ITS CONTRIBUTORS "AS IS" AND ANY EXPRESS OR IMPLIED WARRANTIES, INCLUDING, BUT NOT

LIMITED TO, THE IMPLIED WARRANTIES OF MERCHANTABILITY AND FITNESS FOR A PARTICULAR PURPOSE ARE DISCLAIMED. IN NO EVENT SHALL KTH OR ITS CONTRIBUTORS BE LIABLE FOR ANY DIRECT, INDIRECT, INCIDENTAL, SPECIAL, EXEMPLARY, OR CONSEQUENTIAL DAMAGES (INCLUDING, BUT NOT LIMITED TO, PROCUREMENT OF SUBSTITUTE GOODS OR SERVICES; LOSS OF USE, DATA, OR PROFITS; OR BUSINESS INTERRUPTION) HOWEVER CAUSED AND ON ANY THEORY OF LIABILITY, WHETHER IN CONTRACT, STRICT LIABILITY, OR TORT (INCLUDING NEGLIGENCE OR OTHERWISE) ARISING IN ANY WAY OUT OF THE USE OF THIS SOFTWARE, EVEN IF ADVISED OF THE POSSIBILITY OF SUCH DAMAGE.

Alexey Zelkin

Copyright (c) 2000, 2001 Alexey Zelkin <phantom@FreeBSD.org> All rights reserved.

Redistribution and use in source and binary forms, with or without modification, are permitted provided that the following conditions are met:

1. Redistributions of source code must retain the above copyright notice, this list of conditions and the following disclaimer.
2. Redistributions in binary form must reproduce the above copyright notice, this list of conditions and the following disclaimer in the documentation and/or other materials provided with the distribution.

THIS SOFTWARE IS PROVIDED BY THE AUTHOR AND CONTRIBUTORS "AS IS" AND ANY EXPRESS OR IMPLIED WARRANTIES, INCLUDING, BUT NOT LIMITED TO, THE IMPLIED WARRANTIES OF MERCHANTABILITY AND FITNESS FOR A PARTICULAR PURPOSE ARE DISCLAIMED. IN NO EVENT SHALL THE AUTHOR OR CONTRIBUTORS BE LIABLE FOR ANY DIRECT, INDIRECT, INCIDENTAL, SPECIAL, EXEMPLARY, OR CONSEQUENTIAL DAMAGES (INCLUDING, BUT NOT LIMITED TO, PROCUREMENT OF SUBSTITUTE GOODS OR SERVICES; LOSS OF USE, DATA, OR PROFITS; OR BUSINESS INTERRUPTION) HOWEVER CAUSED AND ON ANY THEORY OF LIABILITY, WHETHER IN CONTRACT, STRICT LIABILITY, OR TORT (INCLUDING NEGLIGENCE OR OTHERWISE) ARISING IN ANY WAY OUT OF THE USE OF THIS SOFTWARE, EVEN IF ADVISED OF THE POSSIBILITY OF SUCH DAMAGE.

Andrey A. Chernov

Copyright (C) 1997 by Andrey A. Chernov, Moscow, Russia. All rights reserved.

Redistribution and use in source and binary forms, with or without modification, are permitted provided that the following conditions are met:

1. Redistributions of source code must retain the above copyright notice, this list of conditions and the following disclaimer.
2. Redistributions in binary form must reproduce the above copyright notice, this list of conditions and the following disclaimer in the documentation and/or other materials provided with the distribution.

THIS SOFTWARE IS PROVIDED BY THE AUTHOR "AS IS" AND ANY EXPRESS OR IMPLIED WARRANTIES, INCLUDING, BUT NOT LIMITED TO, THE IMPLIED WARRANTIES OF MERCHANTABILITY AND FITNESS FOR A PARTICULAR PURPOSE ARE DISCLAIMED. IN NO EVENT SHALL THE REGENTS OR CONTRIBUTORS BE LIABLE FOR ANY DIRECT, INDIRECT, INCIDENTAL, SPECIAL, EXEMPLARY, OR CONSEQUENTIAL DAMAGES (INCLUDING, BUT NOT LIMITED TO, PROCUREMENT OF SUBSTITUTE GOODS OR SERVICES; LOSS OF USE, DATA, OR PROFITS; OR BUSINESS INTERRUPTION) HOWEVER CAUSED AND ON ANY THEORY OF LIABILITY, WHETHER IN CONTRACT, STRICT LIABILITY, OR TORT (INCLUDING NEGLIGENCE OR OTHERWISE)

ARISING IN ANY WAY OUT OF THE USE OF THIS SOFTWARE, EVEN IF ADVISED OF THE POSSIBILITY OF SUCH DAMAGE.

FreeBSD

Copyright (c) 1997-2002 FreeBSD Project.

All rights reserved.

Redistribution and use in source and binary forms, with or without modification, are permitted provided that the following conditions are met:

1. Redistributions of source code must retain the above copyright notice, this list of conditions and the following disclaimer.
2. Redistributions in binary form must reproduce the above copyright notice, this list of conditions and the following disclaimer in the documentation and/or other materials provided with the distribution.

THIS SOFTWARE IS PROVIDED BY THE AUTHOR AND CONTRIBUTORS "AS IS" AND ANY EXPRESS OR IMPLIED WARRANTIES, INCLUDING, BUT NOT LIMITED TO, THE IMPLIED WARRANTIES OF MERCHANTABILITY AND FITNESS FOR A PARTICULAR PURPOSE ARE DISCLAIMED. IN NO EVENT SHALL THE AUTHOR OR CONTRIBUTORS BE LIABLE FOR ANY DIRECT, INDIRECT, INCIDENTAL, SPECIAL, EXEMPLARY, OR CONSEQUENTIAL DAMAGES (INCLUDING, BUT NOT LIMITED TO, PROCUREMENT OF SUBSTITUTE GOODS OR SERVICES; LOSS OF USE, DATA, OR PROFITS; OR BUSINESS INTERRUPTION) HOWEVER CAUSED AND ON ANY THEORY OF LIABILITY, WHETHER IN CONTRACT, STRICT LIABILITY, OR TORT (INCLUDING NEGLIGENCE OR OTHERWISE) ARISING IN ANY WAY OUT OF THE USE OF THIS SOFTWARE, EVEN IF ADVISED OF THE POSSIBILITY OF SUCH DAMAGE.

S. L. Moshier

Author: S. L. Moshier.

Copyright (c) 1984, 2000 S.L. Moshier
Permission to use, copy, modify, and distribute this software for any purpose without fee is hereby granted, provided that this entire notice is included in all copies of any software which is or includes a copy or modification of this software and in all copies of the supporting documentation for such software.

THIS SOFTWARE IS BEING PROVIDED "AS IS", WITHOUT ANY EXPRESS OR IMPLIED WARRANTY. IN PARTICULAR, THE AUTHOR MAKES NO REPRESENTATION OR WARRANTY OF ANY KIND CONCERNING THE MERCHANTABILITY OF THIS SOFTWARE OR ITS FITNESS FOR ANY PARTICULAR PURPOSE.

Citrus Project

Copyright (c)1999 Citrus Project. All rights reserved.

Redistribution and use in source and binary forms, with or without modification, are permitted provided that the following conditions are met:

1. Redistributions of source code must retain the above copyright notice, this list of conditions and the following disclaimer.
2. Redistributions in binary form must reproduce the above copyright notice, this list of conditions and the following disclaimer in the documentation and/or other materials provided with the distribution.

THIS SOFTWARE IS PROVIDED BY THE AUTHOR AND CONTRIBUTORS "AS IS" AND ANY EXPRESS OR IMPLIED WARRANTIES, INCLUDING, BUT NOT LIMITED TO, THE IMPLIED WARRANTIES OF MERCHANTABILITY AND FITNESS FOR A PARTICULAR PURPOSE ARE DISCLAIMED. IN NO EVENT SHALL THE AUTHOR OR CONTRIBUTORS BE LIABLE FOR ANY DIRECT, INDIRECT, INCIDENTAL, SPECIAL, EXEMPLARY, OR CONSEQUENTIAL DAMAGES (INCLUDING, BUT NOT LIMITED TO, PROCUREMENT OF

SUBSTITUTE GOODS OR SERVICES; LOSS OF USE, DATA, OR PROFITS; OR BUSINESS INTERRUPTION) HOWEVER CAUSED AND ON ANY THEORY OF LIABILITY, WHETHER IN CONTRACT, STRICT LIABILITY, OR TORT (INCLUDING NEGLIGENCE OR OTHERWISE) ARISING IN ANY WAY OUT OF THE USE OF THIS SOFTWARE, EVEN IF ADVISED OF THE POSSIBILITY OF SUCH DAMAGE.

Todd C. Miller

Copyright (c) 1998 Todd C. Miller <Todd.Miller@courtesan.com> All rights reserved.

Redistribution and use in source and binary forms, with or without modification, are permitted provided that the following conditions are met:

1. Redistributions of source code must retain the above copyright notice, this list of conditions and the following disclaimer.
2. Redistributions in binary form must reproduce the above copyright notice, this list of conditions and the following disclaimer in the documentation and/or other materials provided with the distribution.
3. The name of the author may not be used to endorse or promote products derived from this software without specific prior written permission.

THIS SOFTWARE IS PROVIDED "AS IS" AND ANY EXPRESS OR IMPLIED WARRANTIES, INCLUDING, BUT NOT LIMITED TO, THE IMPLIED WARRANTIES OF MERCHANTABILITY AND FITNESS FOR A PARTICULAR PURPOSE ARE DISCLAIMED. IN NO EVENT SHALL THE AUTHOR BE LIABLE FOR ANY DIRECT, INDIRECT, INCIDENTAL, SPECIAL, EXEMPLARY, OR CONSEQUENTIAL DAMAGES (INCLUDING, BUT NOT LIMITED TO, PROCUREMENT OF SUBSTITUTE GOODS OR SERVICES; LOSS OF USE, DATA, OR PROFITS; OR BUSINESS INTERRUPTION) HOWEVER CAUSED AND ON ANY THEORY OF LIABILITY, WHETHER IN CONTRACT, STRICT LIABILITY, OR TORT (INCLUDING NEGLIGENCE OR OTHERWISE) ARISING IN ANY WAY OUT OF THE USE OF THIS SOFTWARE, EVEN IF ADVISED OF THE POSSIBILITY OF SUCH DAMAGE.

DJ Delorie (i386)

Copyright (C) 1991 DJ Delorie. All rights reserved.

Redistribution, modification, and use in source and binary forms is permitted provided that the above copyright notice and following paragraph are duplicated in all such forms.

This file is distributed WITHOUT ANY WARRANTY; without even the implied warranty of MERCHANTABILITY or FITNESS FOR A PARTICULAR PURPOSE.

Mike Barcroft

Copyright (c) 2001 Mike Barcroft <mike@FreeBSD.org> All rights reserved.

Redistribution and use in source and binary forms, with or without modification, are permitted provided that the following conditions are met:

1. Redistributions of source code must retain the above copyright notice, this list of conditions and the following disclaimer.
2. Redistributions in binary form must reproduce the above copyright notice, this list of conditions and the following disclaimer in the documentation and/or other materials provided with the distribution.

THIS SOFTWARE IS PROVIDED BY THE AUTHOR AND CONTRIBUTORS "AS IS" AND ANY EXPRESS OR IMPLIED WARRANTIES, INCLUDING, BUT NOT LIMITED TO, THE IMPLIED WARRANTIES OF MERCHANTABILITY AND FITNESS FOR A PARTICULAR PURPOSE ARE DISCLAIMED. IN NO EVENT SHALL THE AUTHOR OR CONTRIBUTORS BE LIABLE FOR ANY DIRECT, INDIRECT, INCIDENTAL, SPECIAL, EXEMPLARY, OR

CONSEQUENTIAL DAMAGES (INCLUDING, BUT NOT LIMITED TO, PROCUREMENT OF SUBSTITUTE GOODS OR SERVICES; LOSS OF USE, DATA, OR PROFITS; OR BUSINESS INTERRUPTION) HOWEVER CAUSED AND ON ANY THEORY OF LIABILITY, WHETHER IN CONTRACT, STRICT LIABILITY, OR TORT (INCLUDING NEGLIGENCE OR OTHERWISE) ARISING IN ANY WAY OUT OF THE USE OF THIS SOFTWARE, EVEN IF ADVISED OF THE POSSIBILITY OF SUCH DAMAGE.

ARM Ltd (arm and thumb variant targets only)

Copyright (c) 2009 ARM Ltd. All rights reserved.

Redistribution and use in source and binary forms, with or without modification, are permitted provided that the following conditions are met:

1. Redistributions of source code must retain the above copyright notice, this list of conditions and the following disclaimer.
2. Redistributions in binary form must reproduce the above copyright notice, this list of conditions and the following disclaimer in the documentation and/or other materials provided with the distribution.
3. The name of the company may not be used to endorse or promote products derived from this software without specific prior written permission.

THIS SOFTWARE IS PROVIDED BY ARM LTD "AS IS" AND ANY EXPRESS OR IMPLIED WARRANTIES, INCLUDING, BUT NOT LIMITED TO, THE IMPLIED WARRANTIES OF MERCHANTABILITY AND FITNESS FOR A PARTICULAR PURPOSE ARE DISCLAIMED. IN NO EVENT SHALL ARM LTD BE LIABLE FOR ANY DIRECT, INDIRECT, INCIDENTAL, SPECIAL, EXEMPLARY, OR CONSEQUENTIAL DAMAGES (INCLUDING, BUT NOT LIMITED TO, PROCUREMENT OF SUBSTITUTE GOODS OR SERVICES; LOSS OF USE, DATA, OR PROFITS; OR BUSINESS INTERRUPTION) HOWEVER CAUSED AND ON ANY THEORY OF LIABILITY, WHETHER IN CONTRACT, STRICT LIABILITY, OR TORT (INCLUDING NEGLIGENCE OR OTHERWISE) ARISING IN ANY WAY OUT OF THE USE OF THIS SOFTWARE, EVEN IF ADVISED OF THE POSSIBILITY OF SUCH DAMAGE.

Xilinx, Inc. (microblaze* and powerpc* targets)

Copyright (c) 2004, 2009 Xilinx, Inc. All rights reserved.

Redistribution and use in source and binary forms, with or without modification, are permitted provided that the following conditions are met:

1. Redistributions source code must retain the above copyright notice, this list of conditions and the following disclaimer.
2. Redistributions in binary form must reproduce the above copyright notice, this list of conditions and the following disclaimer in the documentation and/or other materials provided with the distribution.
3. Neither the name of Xilinx nor the names of its contributors may be used to endorse or promote products derived from this software without specific prior written permission.

THIS SOFTWARE IS PROVIDED BY THE COPYRIGHT HOLDER AND CONTRIBUTORS "AS IS" AND ANY EXPRESS OR IMPLIED WARRANTIES, INCLUDING, BUT NOT LIMITED TO, THE IMPLIED WARRANTIES OF MERCHANTABILITY AND FITNESS FOR A PARTICULAR PURPOSE ARE DISCLAIMED. IN NO EVENT SHALL THE COPYRIGHT HOLDER OR CONTRIBUTORS BE LIABLE FOR ANY DIRECT, INDIRECT, INCIDENTAL, SPECIAL, EXEMPLARY, OR CONSEQUENTIAL DAMAGES (INCLUDING, BUT NOT LIMITED TO, PROCUREMENT OF SUBSTITUTE GOODS OR SERVICES; LOSS OF USE, DATA, OR PROFITS; OR BUSINESS INTERRUPTION) HOWEVER CAUSED AND

ON ANY THEORY OF LIABILITY, WHETHER IN CONTRACT, STRICT LIABILITY, OR TORT (INCLUDING NEGLIGENCE OR OTHERWISE) ARISING IN ANY WAY OUT OF THE USE OF THIS SOFTWARE, EVEN IF ADVISED OF THE POSSIBILITY OF SUCH DAMAGE.

Ed Schouten - Free BSD

Copyright (c) 2008 Ed Schouten <ed@FreeBSD.org> All rights reserved.

Redistribution and use in source and binary forms, with or without modification, are permitted provided that the following conditions are met:

1. Redistributions of source code must retain the above copyright notice, this list of conditions and the following disclaimer.
2. Redistributions in binary form must reproduce the above copyright notice, this list of conditions and the following disclaimer in the documentation and/or other materials provided with the distribution.

THIS SOFTWARE IS PROVIDED BY THE AUTHOR AND CONTRIBUTORS "AS IS" AND ANY EXPRESS OR IMPLIED WARRANTIES, INCLUDING, BUT NOT LIMITED TO, THE IMPLIED WARRANTIES OF MERCHANTABILITY AND FITNESS FOR A PARTICULAR PURPOSE ARE DISCLAIMED. IN NO EVENT SHALL THE AUTHOR OR CONTRIBUTORS BE LIABLE FOR ANY DIRECT, INDIRECT, INCIDENTAL, SPECIAL, EXEMPLARY, OR CONSEQUENTIAL DAMAGES (INCLUDING, BUT NOT LIMITED TO, PROCUREMENT OF SUBSTITUTE GOODS OR SERVICES; LOSS OF USE, DATA, OR PROFITS; OR BUSINESS INTERRUPTION) HOWEVER CAUSED AND ON ANY THEORY OF LIABILITY, WHETHER IN CONTRACT, STRICT LIABILITY, OR TORT (INCLUDING NEGLIGENCE OR OTHERWISE) ARISING IN ANY WAY OUT OF THE USE OF THIS SOFTWARE, EVEN IF ADVISED OF THE POSSIBILITY OF SUCH DAMAGE.

lwIP 2.1.2 - TCP/IP stack

Copyright (c) 2001-2003 Swedish Institute of Computer Science. All rights reserved.

Copyright (c) 2001-2004 Swedish Institute of Computer Science. All rights reserved.

Copyright (c) 2018 Swedish Institute of Computer Science. All rights reserved.

Copyright (c) 2017 Dirk Ziegelmeier. All rights reserved.

Redistribution and use in source and binary forms, with or without modification, are permitted provided that the following conditions are met:

1. Redistributions of source code must retain the above copyright notice, this list of conditions and the following disclaimer.
2. Redistributions in binary form must reproduce the above copyright notice, this list of conditions and the following disclaimer in the documentation and/or other materials provided with the distribution.
3. The name of the author may not be used to endorse or promote products derived from this software without specific prior written permission.

THIS SOFTWARE IS PROVIDED BY THE AUTHOR "AS IS" AND ANY EXPRESS OR IMPLIED WARRANTIES, INCLUDING, BUT NOT LIMITED TO, THE IMPLIED WARRANTIES OF MERCHANTABILITY AND FITNESS FOR A PARTICULAR PURPOSE ARE DISCLAIMED. IN NO EVENT SHALL THE AUTHOR BE LIABLE FOR ANY DIRECT, INDIRECT, INCIDENTAL, SPECIAL, EXEMPLARY, OR CONSEQUENTIAL DAMAGES (INCLUDING, BUT NOT LIMITED TO, PROCUREMENT OF SUBSTITUTE GOODS OR SERVICES; LOSS OF USE, DATA, OR PROFITS; OR BUSINESS INTERRUPTION) HOWEVER CAUSED AND ON ANY THEORY OF LIABILITY, WHETHER IN CONTRACT, STRICT LIABILITY, OR TORT (INCLUDING NEGLIGENCE OR OTHERWISE) ARISING IN ANY WAY OUT OF THE USE OF THIS SOFTWARE, EVEN IF ADVISED OF THE

POSSIBILITY OF SUCH DAMAGE.

Author(s):

- Adam Dunkels <adam@sics.se>
- Simon Goldschmidt <goldsimon@gmx.de>
- Dirk Ziegelmeier <dziegel@gmx.de>

lwIP 2.1.2 - SNMP agent

Copyright (c) 2006 Axon Digital Design B.V., The Netherlands. All rights reserved.

Copyright (c) 2016 Elias Oenal. All rights reserved.

Copyright (c) 2016 Elias Oenal and Dirk Ziegelmeier. All rights reserved.

Copyright (c) 2015 Dirk Ziegelmeier. All rights reserved.

Copyright (c) 2001, 2002 Leon Woestenberg <leon.woestenberg@axon.tv>

Copyright (c) 2001, 2002 Axon Digital Design B.V., The Netherlands. All rights reserved.

Redistribution and use in source and binary forms, with or without modification, are permitted provided that the following conditions are met:

1. Redistributions of source code must retain the above copyright notice, this list of conditions and the following disclaimer.
2. Redistributions in binary form must reproduce the above copyright notice, this list of conditions and the following disclaimer in the documentation and/or other materials provided with the distribution.
3. The name of the author may not be used to endorse or promote products derived from this software without specific prior written permission.

THIS SOFTWARE IS PROVIDED BY THE AUTHOR "AS IS" AND ANY EXPRESS OR IMPLIED WARRANTIES, INCLUDING, BUT NOT LIMITED TO, THE IMPLIED WARRANTIES OF MERCHANTABILITY AND FITNESS FOR A PARTICULAR PURPOSE ARE DISCLAIMED. IN NO EVENT SHALL THE AUTHOR BE LIABLE FOR ANY DIRECT, INDIRECT, INCIDENTAL, SPECIAL, EXEMPLARY, OR CONSEQUENTIAL DAMAGES (INCLUDING, BUT NOT LIMITED TO, PROCUREMENT OF SUBSTITUTE GOODS OR SERVICES; LOSS OF USE, DATA, OR PROFITS; OR BUSINESS INTERRUPTION) HOWEVER CAUSED AND ON ANY THEORY OF LIABILITY, WHETHER IN CONTRACT, STRICT LIABILITY, OR TORT (INCLUDING NEGLIGENCE OR OTHERWISE) ARISING IN ANY WAY OUT OF THE USE OF THIS SOFTWARE, EVEN IF ADVISED OF THE POSSIBILITY OF SUCH DAMAGE.

Author(s):

- Dirk Ziegelmeier <dziegel@gmx.de>
- Christiaan Simons <christiaan.simons@axon.tv>
- Martin Hentschel <info@cl-soft.de>
- Elias Oenal <lwip@eliasoenal.com>
- Leon Woestenberg <leon.woestenberg@axon.tv>

18 Alphabetical index

| | | | |
|---------------------------------------|--------|--|--------|
| A | | E | |
| Abbreviations | 8 | Error diagnosis | 82 |
| Ambient conditions | 29 | Error memory | 82 |
| Ambient temperature | 29 | Extension | 80 |
| at zero stroke pressure | 20 | External pilot oil supply | 28 |
| B | | F | |
| Basic operating modes | 21 | Fault table | 83 |
| Brief regenerative operation | 26 | Feedforward control factor for slave | 70 |
| C | | Filling | 59 |
| Cable kits | 53 | Filtration | 30 |
| Cabling | 52 | Flange pattern | 50 |
| Calibration | 70 | Flushing | 60 |
| Care | 73 | Functional description | 17 |
| Case drain piping | 45 | G | |
| Change | | Gate time | 69 |
| Pilot valve VT-DFPD-X-1X | 76 | Generation of noise | 31 |
| Swivel angle sensor VT-SWA-LIN- | | H | |
| ...-G15 | 76 | HFC fluids | 31 |
| Changing over to master/slave | | Hydraulic fluid | 59 |
| operation | 34 | Filtration | 30 |
| Checking the swivel angle measurement | | Selection | 29 |
| 86 | | I | |
| Check swivel angle "100 %" | 86 | Identification | 37 |
| Check swivel angle "zero" | 86 | IndraWorks | |
| Circuitry | 33 | Description | 35 |
| Circulation operation | 23, 35 | IndraWorks commissioning tool | 35 |
| Cleaning | 73 | Inspection | 73 |
| Commissioning | 58 | Inspection schedule | 73 |
| initial | 59 | Installation | 42, 46 |
| Connecting | | completing | 48 |
| electrically | 52 | general notes | 47 |
| hydraulically | 48 | Preparations | 46 |
| Continuous regenerative operation .. | 24 | with coupling | 47 |
| Controller parameters | | Installation conditions | 42 |
| adjusting | 65 | Installation drawing | 6 |
| Conversion | 80 | Installation orientation | 44 |
| Coupling | 47 | Installation position | 43 |
| D | | Intended use | 10 |
| Damage to property | | Internal pilot oil supply | 27 |
| general notes | 15 | K | |
| D-component | 67 | Keyed shaft | 32 |
| Decommissioning | 77 | L | |
| Default address of the SY(H)DFED | | Lifting tool | 38 |
| control system | 60 | List of addresses | 88 |
| Demounting | 78 | M | |
| Demounting | 78 | Maintenance | 74 |
| Preparing | 78 | | |
| Device description | 17 | | |
| Dimensions | | | |
| Connections | 47 | | |
| Direction of rotation | 46 | | |
| Disposal | 79 | | |
| Documentations | 6 | | |

| | | | |
|--|--------|---|--------|
| Maintenance and repair | 73 | Required documentation | 6 |
| Maintenance intervals | 73 | Ring screw | 39 |
| Master/slave operation | 33 | Running-in phase | 72 |
| changeover | 34 | | |
| deactivating | 35 | S | |
| Maximum operating pressure | 27 | Safety instructions | 10 |
| Minimum operating pressure | 27 | general | 11 |
| Mounting tool | 77 | Signal word | 7 |
| | | Seal kits | 76 |
| N | | Second P-gain | 66 |
| Nameplate | 37 | Selection of the pressure transducers .. | 56 |
| Notes on dimensioning | 28 | Select the active actual pressure value . | 69 |
| | | Set the pressure controller PD-gain | 67 |
| O | | Shaft variant | 32 |
| Obligations of the machine end-user | 14 | Spare parts | 75 |
| Oil-immersed applications | 29 | Splined shaft | 32 |
| Open circuit | 17 | Spool variants of pilot valve | 32 |
| Open Source Software | 89 | Stand-by operation | 23 |
| Operating modes | | Starting up at zero pressure | 23 |
| special | 23 | Startup | 23 |
| Operating pressure | | at zero pressure | 23, 35 |
| maximum | 27 | Storage | 38, 40 |
| minimum | 27 | Storage time | 40 |
| Operating viscosity | 29 | Switch-on sequence | 36 |
| Operation | 72 | Swivel angle measurement check | 86 |
| Order confirmation | 6 | Swivel angle sensor | |
| | | mounting | 76 |
| P | | Symbols | 8 |
| Performance description | 17 | System requirements | 35 |
| Personal protective equipment | 14 | | |
| P-gain | 66 | T | |
| Pilot oil | 27 | Technical data | 87 |
| external | 28 | Temperature range | 29 |
| internal | 27 | Test box for SYDFED | 77 |
| Pilot valve | 53, 76 | Test devices | 77 |
| connecting electrically | 53 | Testing the hydraulic fluid supply | 60 |
| Power supply | 55 | Tightening torques | 50 |
| replacing | 76 | Tools | 78 |
| Spool variant | 32 | Transport | 38 |
| Pilot valve VT-DFPD-X-1X | 76 | with lifting gear | 39 |
| Piping | 43, 44 | with lifting strap | 39 |
| Pre-load valve | 27 | with ring screw | 39 |
| bleeding | 65 | Troubleshooting | 81 |
| Preload valve | 76 | | |
| Pressure transducer | 56 | U | |
| HM20 | 56 | Unpacking | 42 |
| Mounting orientation | 56, 57 | Use | |
| Place of mounting | 56, 57 | improper | 10 |
| Selection | 56 | intended | 10 |
| Product description | 17 | | |
| Pulsation damper | 31 | V | |
| | | Viscosity | 29 |
| Q | | Viscosity limits | 29 |
| Qualification of personnel | 11 | | |
| | | W | |
| R | | Warranty | 48, 59 |
| Recommissioning after standstill | 71 | Weights | 38 |
| Regenerative operation | 24 | | |
| Replacement of components | 75 | | |

Z

Zero stroke operation 23

www.sumy.ir

www.sumy.ir

Bosch Rexroth AG

Industrial Hydraulics
Zum Eisengiesser 1
97816 Lohr a. Main
Germany
Phone +49 (0) 9352/18-0
my.support@boschrexroth.com
www.boschrexroth.com

www.sumy.ir