



FLR-RHR SERIES

In line medium pressure filters

In line filters for operating pressure up to 30 bar.
Flow rate up to 2600 l/min.



HOUSING	tested according to NFPA T3.10.5.1, ISO 10771, ISO 3968
PRESSURE:	Max operating: 30 bar Fatigue rating: 10 ⁶ cycles 0÷30 bar Burst: 90 bar
CONNECTIONS:	3" - 4" SAE 3000 FLANGE
MATERIALS:	Head: anodized aluminium Bowl: anodized aluminium Body: anticorodal aluminium Seal: NBR (FKM on request)
BYPASS VALVE:	inbuilt in the filter element no bypass 1 bar 3 bar 4 bar 6 bar
ELEMENT	tested according to ISO 11170, 2941, 2942, 2943, 3724, 3968, 16889, 16908, 23181
FILTER MEDIA:	Fibreglass: G01 - G03 - G05 - G10 G15 - G20 - G40 - GW03 - GW10 AW40
COLLAPSE PRESSURE:	20 bar
TEMPERATURE RANGE:	with NBR seal from -30 °C to +100 °C with FKM seal (OPTION) from -25 °C to +120 °C
FLUID COMPATIBILITY:	Full with HH-HL-HM-HV HETG-HEES (acc. to ISO 6743/4). For use with other fluid please contact Filtrec Customer Service (info@filtrec.it).

OVERALL DIMENSIONS

A Version

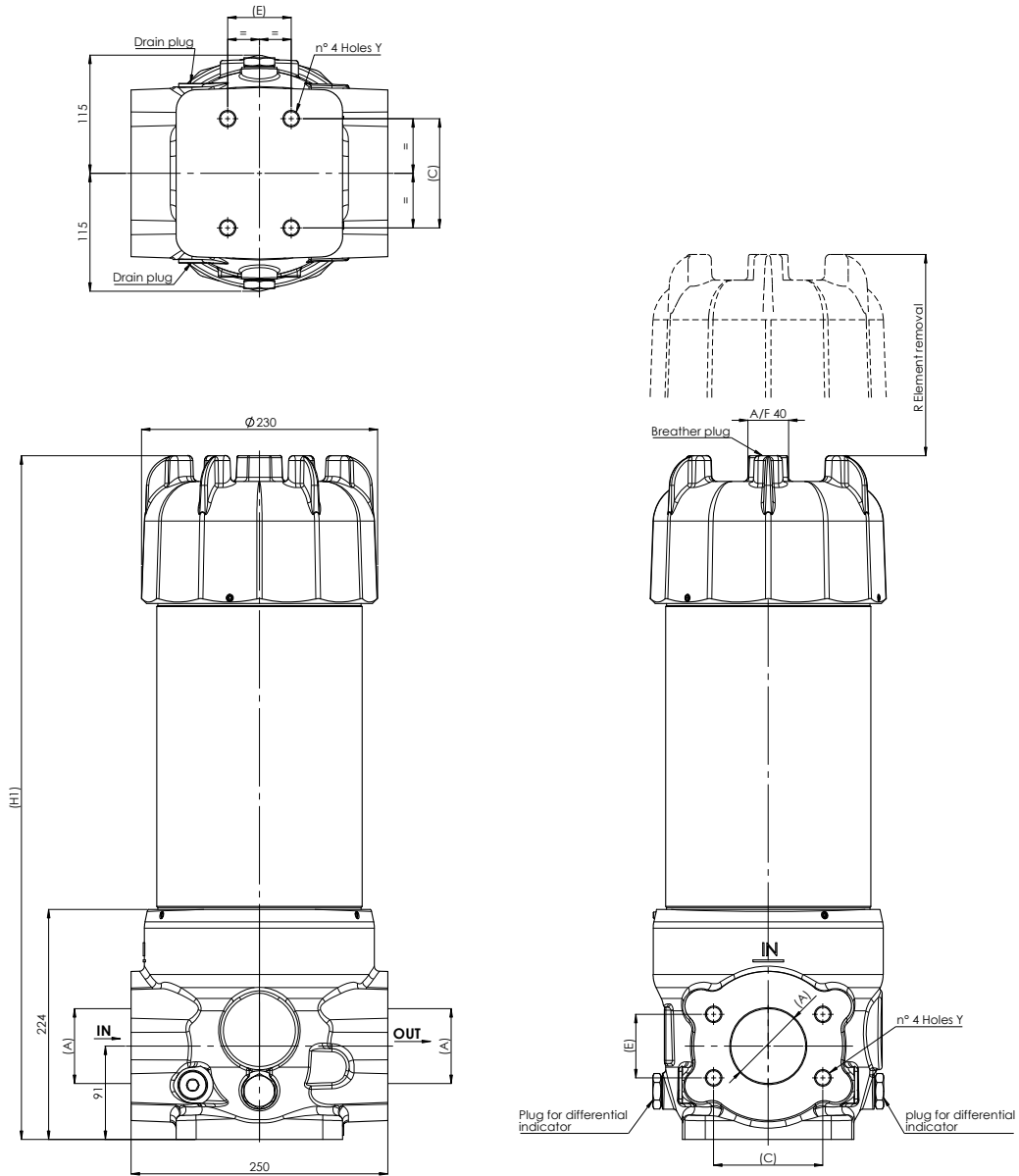

OVERALL DIMENSIONS

B Version

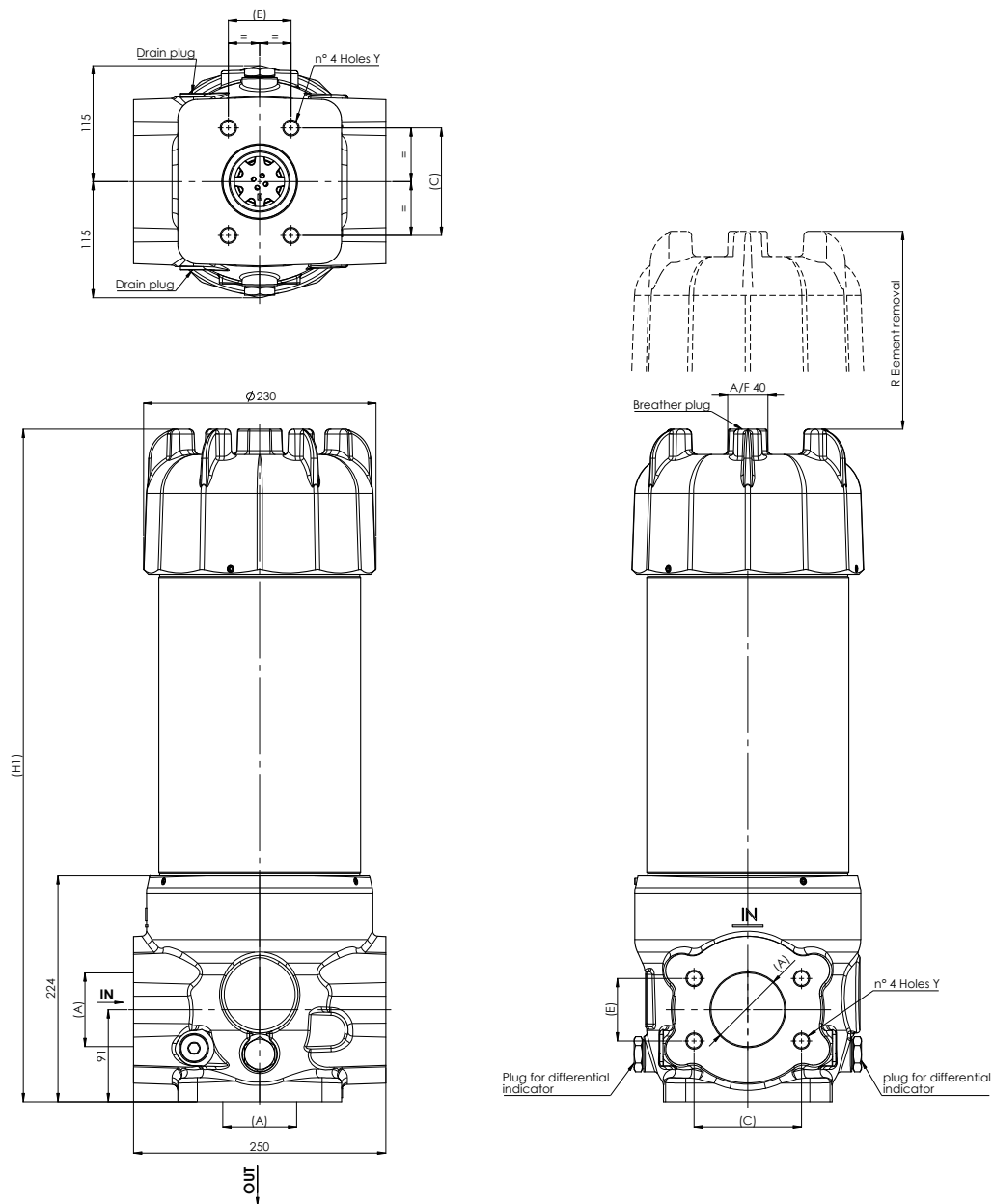

NOMINAL SIZE

MODEL	PORT SIZE A	Y	A	C	E	H1	R	BODY WEIGHT
FLR-RHR1300	FLANGE 3" SAE 3000-M	M16 x 24	$\varnothing 73$	106,38	61,93	718	460	29 Kg
	FLANGE 4" SAE 3000-M		$\varnothing 99$	130,18	77,77			
FLR-RHR2600	FLANGE 3" SAE 3000-M		$\varnothing 73$	106,38	61,93	1156	900	35 Kg
	FLANGE 4" SAE 3000-M		$\varnothing 99$	130,18	77,77			

ORDERING INFORMATION

	1.	2.	3.	4.	5.	6.	7.	8.	9.	10.	11.	12.	13.
	FLR	RHR	2600	G10	B	6	AB1	F10M	A	1	000	A	0
SPARE ELEMENT		RHR	2600	G10	B	6	/AB1						

1. FILTER SERIES	FLR	
2. FILTER ELEMENT SERIES	RHR	
3. FILTER SIZE	1300	
	2600	
4. FILTER MEDIA	000	no element
	G01	glassfiber $\beta_{4\mu m(c)} \geq 1.000$
	G03	glassfiber $\beta_{5\mu m(c)} \geq 1.000$
	G05	glassfiber $\beta_{7\mu m(c)} \geq 1.000$
	G10	glassfiber $\beta_{12\mu m(c)} \geq 1.000$
	G15	glassfiber $\beta_{17\mu m(c)} \geq 1.000$
	G20	glassfiber $\beta_{22\mu m(c)} \geq 1.000$
	G40	glassfiber $\beta_{35\mu m(c)} \geq 1.000$
	GW03	glassfiber $\beta_{5\mu m(c)} \geq 1.000$ + water absorbent
	GW10	glassfiber $\beta_{12\mu m(c)} \geq 1.000$ + water absorbent
	AW40	water absorbent only
5. SEALS	B	NBR
	V	FKM
6. BYPASS VALVE	0	no bypass or no element
Inbuilt into the filter element	1	1 bar
	3	3 bar
	4	4 bar
	6	6 bar
7. ELEMENT SUFFIX	0	no element (empty housing config)
	AB1	AbsoluteBeta - HIGH CAPACITY FILTER ELEMENT $\varnothing_{ext} = 143mm$
	012	AbsoluteBeta - ULTRA HIGH CAPACITY FILTER ELEMENT $\varnothing_{ext} = 153mm$
	005	AbsoluteBeta - HIGH CAPACITY FILTER ELEMENT $\varnothing_{ext} = 143mm$ + safety element 50mic for bypass valve
	014	AbsoluteBeta - ULTRA HIGH CAPACITY FILTER ELEMENT $\varnothing_{ext} = 153mm$ + safety element 50mic for bypass valve
8. MAIN PORT	F10M	3" SAE 3000 FLANGE
	F12M	4" SAE 3000 FLANGE

ORDERING INFORMATION

9. PORTS LAYOUT	A	straight: horizontal inlet - horizontal outlet
	B	corner: horizontal inlet - vertical outlet
10. INDICATOR PORT OPTION	1	indicator seat on both sides: left metal plug, right plastic cap
	2	indicator seat on both sides with metal plug
11. COMPULSORY FIELD	000	filtrec standard
12. CORROSION PROTECTION	A	anodized
13. OPTION	0	no option
	1	internal tube for low flow rate 150-200 LPM (not suitable with elements suffix "/005" and "/014")

ACCESSORIES

The accessories must be ordered separately

INDICATOR

(Y and F) digit for FKM seal option

*LC24=Led connector

For other options see clogging indicators catalogue

VX2 (VY2)	differential visual 2,7bar	
EX2 (EY2)	differential electric 2,7bar	
EX2L (EY2L)	differential electric 2,7bar + LC24*	
VEXF2	differential visual and electric 2,7 bar	
VX5 (VY5)	differential visual 5bar	
EX5 (EY5)	differential electric 5bar	
EX5L (EY5L)	differential electric 5bar + LC24*	
VEXF5	differential visual and electric 5bar	
VX8 (VY8)	differential visual 8bar	
EX8 (EY8)	differential electric 8bar	recommended for no by-pass option
EX8L (EY8L)	differential electric 8bar + LC24*	
VEXF8	differential visual and electric 8 bar	
LC24	LED connector for pressure switch	

PLUG

P01	metal plug for indicator port - NBR
PF1	metal plug for indicator port - FKM

HYDRAULIC SYMBOLS

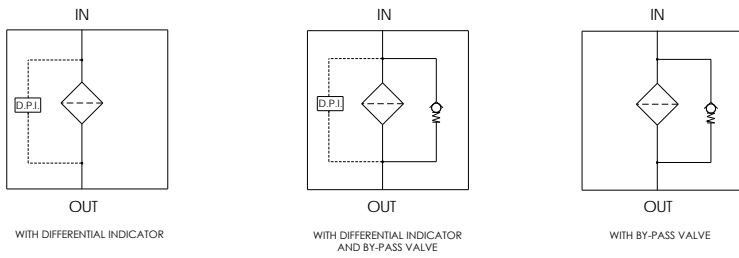

PRESSURE DROP (Δp) INFORMATION FOR FILTER SIZING

The total Delta P through a filter assembly is given from Housing Δp + Element Δp . This ideally should not exceed 1,0 bar and should never exceed 1/3 of the set value of the by-pass valve. N.B. All the reported data have been obtained at our laboratory, according to specification ISO3968 with mineral oil having 32 cSt viscosity and density 0,875 Kg/dm³.

HOUSING PRESSURE DROP

The housing Δp is given by the curve of the considered model and port, in correspondence of the flow rate value.

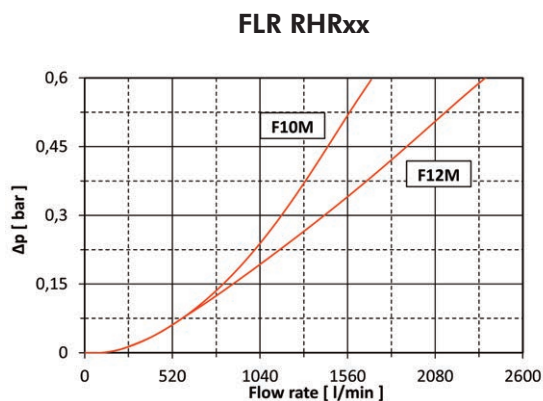

ELEMENT PRESSURE DROP

The element Δp (bar) is given by the flow rate (l/min) multiplied by the factor in the table here below corresponding to the selected media and divided by 1000.

If the oil has a viscosity V_x different than 32 cSt a corrective factor $V_x/32$ must be applied.

1000 l/min with RHR1300G10B0/AB1 and oil viscosity 46 cSt: $(1000 \times 0.33) / 1000 \times (46 / 32) = 0,47$ bar

	G01	G03	G05	G10	G15	G20	G40	GW03	GW10	AW40
RHR1300...AB1 - 005*	1.70	0.70	0.57	0.33	0.30	0.20	0.12	2.1	0.99	0.39
RHR1300...012 - 014*	1.13	0.47	0.38	0.22	0.20	0.13	0.08	1.4	0.66	0.26
RHR2600...AB1 - 005*	0.82	0.34	0.27	0.16	0.14	0.10	0.06	1.02	0.48	0.19
RHR2600...012 - 014*	0.55	0.23	0.18	0.11	0.09	0.07	0.04	0.68	0.32	0.13

*= 005 and 014 element option, suggested for flow up to 500 l/min, for different flow rate please contact Filtrac Customer Service

EXAMPLE OF TOTAL Δp CALCULATION

FLRRHR1300G10B0AB1F10MA00A0 with 1000 l/min and oil 46 cSt:

Housing Δp + element Δp = 0,22 bar + $(1000 \times 0.33) / 1000 \times (46 / 32)$ bar = 0,69 bar

GW03, GW10 AND AW40 QUICK SIZE TABLE

	suggested flow rate [l/min]	GW03 and GW10 water capacity* [l]	AW40 water capacity* [l]
RHR1300...AB1 - 005	51	0.90	1.03
RHR1300...012 - 014	65	1.15	1.31
RHR2600...AB1 - 005	99	1.74	1.98
RHR2600...012 - 014	130	2.28	2.60

* at final Δp = 3 bar

BYPASS VALVE PRESSURE DROP

The bypass valve Δp is given by the curve of the considered model and setting, in correspondence of the flow rate value.

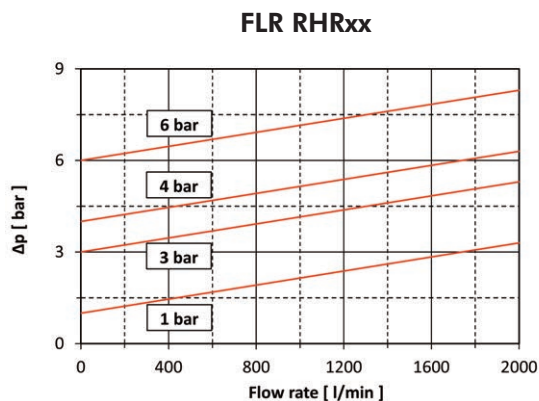

N.B. All the reported data have been obtained at our laboratory, according to specification ISO3968 with mineral oil having 32 cSt viscosity and density 0,875 Kg/dm³.

USER TIPS

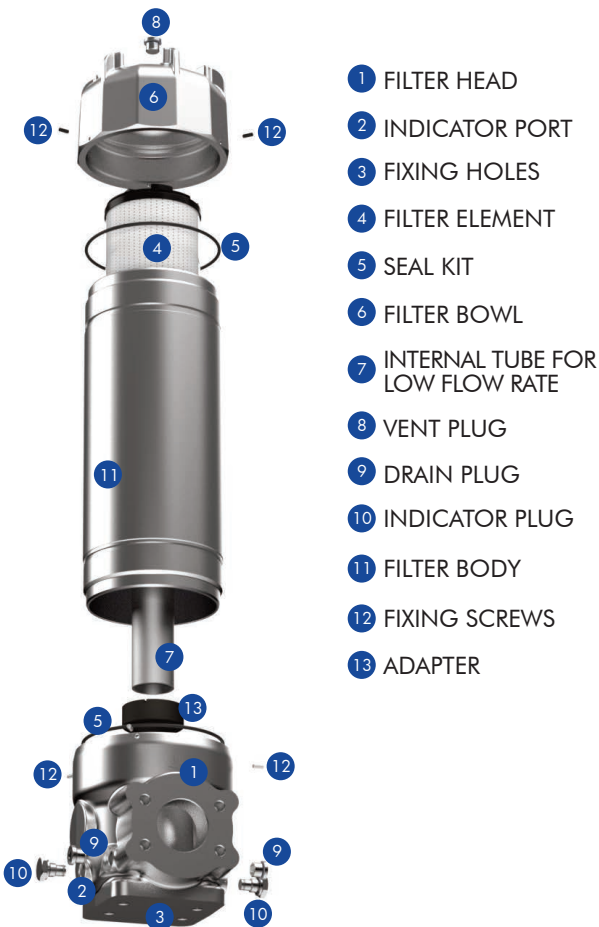

- 1 FILTER HEAD
- 2 INDICATOR PORT
- 3 FIXING HOLES
- 4 FILTER ELEMENT
- 5 SEAL KIT
- 6 FILTER BOWL
- 7 INTERNAL TUBE FOR LOW FLOW RATE
- 8 VENT PLUG
- 9 DRAIN PLUG
- 10 INDICATOR PLUG
- 11 FILTER BODY
- 12 FIXING SCREWS
- 13 ADAPTER

INDICATOR TIGHTENING TORQUE

50 Nm

SPARE SEAL KIT PART NUMBER (5)

	NBR	FKM
FLR...	06.021.00389	06.021.00390

BOWL/BODY TIGHTENING TORQUE

screw up filter bowl/body till end

DRAIN/VENT TIGHTENING TORQUE

50 Nm



WARNING

-  Make sure that Personal Protective Equipment (PPE) is worn during installation and maintenance operation.

DISPOSAL OF FILTER ELEMENT

-  The used filter elements and the filter parts dirty of oil are classified as "Dangerous waste material": they must be disposed according to the local laws by authorized Companies.



INSTALLATION

- 
 1. The IN and OUT ports must be connected to the hoses in the correct flow direction an arrow shows on the filter head (1).
 2. The filter housing should be preferably mounted with the bowl (6) upward.
 3. Secure to the frame the filter head (1) using the fixing holes (3).
 4. Verify that no tension is present on the filter after mounting.
 5. Enough space must be available for filter element replacement.
 6. The visual clogging indicator must be in a easily viewable position.
 7. When a electrical indicator is used, make sure that it is properly wired.
- 
 8. Never run the system with no filter element fitted.
 9. Keep in stock a spare FILTREC filter element for timely replacement when required.
 10. Filter housing should be earthed.

OPERATION

- 
 1. The filter must work within the operating conditions of pressure, temperature and compatibility given in the first page of this data sheet.
 2. The filter element must be replaced as soon as the clogging indicator signals at working temperature (in cold start conditions, oil temperature lower than 30°C, a false alarm can be given due to oil viscosity).
 3. If no clogging indicator is mounted, replace the element according to the system manufacturer's recommendations.

MAINTENANCE

- 
 1. Make sure that the system is switched off and there is no residual pressure in the filter.
 2. Loosen vent screw (8).
 3. Remove drain plug (9) in housing bottom and drain oil.
 4. Unscrew the 3 grub screws (12) of the filter bowl (6).
 5. Unscrew filter bowl counter-clockwise.
 6. Lift out filter element (4).
 7. Check seal on filter bowl (5). We recommend replacement in any case.
 8. Make sure that the order number on the spare element corresponds to the order number of the filter name-plate. To ensure no contamination occurs during the exchange of the element, first open the plastic bag, then push the element over the spigot in the filter head. Now remove plastic bag.
 9. Push the element carefully over the spigot and tighten the 3 grub screws (12) of the filter bowl (6).
 10. Tighten drain plug (9) in housing bottom.
 11. Tight vent screw (8).
-  12. The used filter elements can not be cleaned and re-use.

