



FH100 SERIES

In line pressure filters

Inline filters for operating pressure up to 100 bar.
Flow rate up to 300 l/min



HOUSING	tested according to NFPA T3.10.5.1, ISO 10771, ISO 3968
PRESSURE:	Max operating: 100 bar Fatigue rating: 10 ⁶ cycles 0 ÷ 100 bar Burst: 300 bar
CONNECTIONS:	G 1" ÷ G 1 1/4"
MATERIALS:	Head: cast iron Bowl: carbon steel Seal: NBR (FKM on request)
BYPASS VALVE:	6 bar 3,5 bar (on request) ABF valve ABF valve+ RF valve
ELEMENT	tested according to ISO 11170, 2941, 2942, 2943, 3724, 3968, 16889, 16908, 23181
FILTER MEDIA:	Inorganic microfiber: G01 - G03 - G06 - G10 G15 - G25 Synthetic: M05 - M10 - M15
COLLAPSE PRESSURE:	21 bar 210 bar
TEMPERATURE RANGE:	with NBR seal from -30 °C to +100 °C with FKM seal (OPTION) from -25 °C to +120 °C
FLUID COMPATIBILITY:	Full with HH-HL-HM-HV HETG-HEES (acc. to ISO 6743/4). For use with other fluid please contact Filtrac Customer Service (info@filtrac.it).

OVERALL DIMENSIONS

FH100-D1-3x

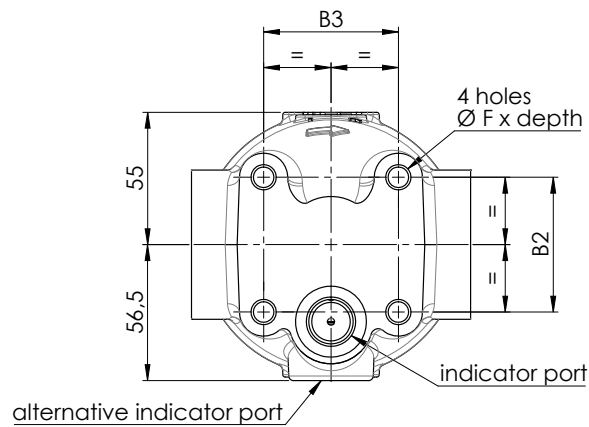
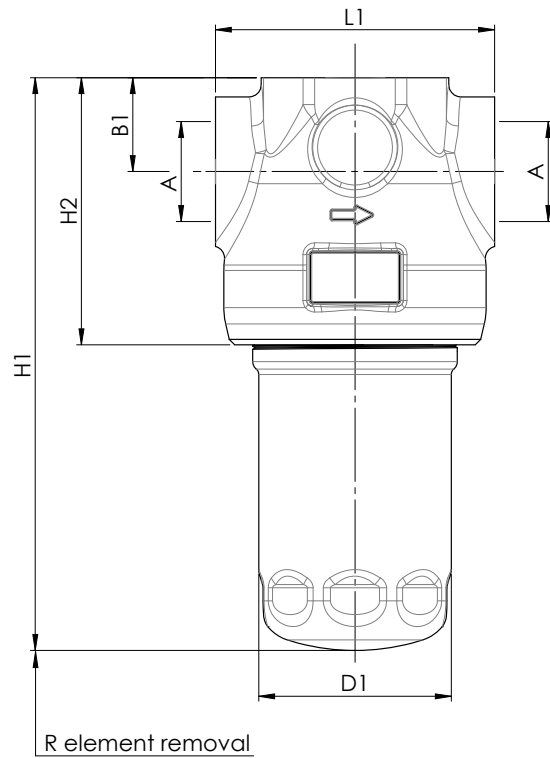

NOMINAL SIZE

MODEL	A	B1	B2	B3	D1	F	H1	H2	L1	R	WEIGHT
FH100-D135	G 1" G 1 1/4"	39	56	56	80	M10X15	238	111	116	120	5,15 Kg
FH100-D136							298				5,5 Kg
FH100-D137							368				5,9 Kg

ORDERING INFORMATION

	1.	2.	3.	4.	5.	6.	7.	8.	9.	10.	11.	12.	13.
	FH100	D1	36	G10	A	B	B5	D	0	S	000	S	0
SPARE ELEMENT	D1	36	G10	A									

1. FILTER SERIES	FH100	
2. FILTER ELEMENT SERIES	D1	
3. FILTER SIZE	35-36-37	
4. FILTER MEDIA	000	no element
For different media options please check availability with Filtrac Customer Service.	G01	glassfiber $\beta_{4\mu\text{m(c)}} \geq 1.000$
	G03	glassfiber $\beta_{5\mu\text{m(c)}} \geq 1.000$
	G06	glassfiber $\beta_{7\mu\text{m(c)}} \geq 1.000$
	G10	glassfiber $\beta_{12\mu\text{m(c)}} \geq 1.000$
	G15	glassfiber $\beta_{17\mu\text{m(c)}} \geq 1.000$
	G25	glassfiber $\beta_{22\mu\text{m(c)}} \geq 1.000$
	M05	synthetic $\beta_{10\mu\text{m(c)}} \geq 1.000$
	M10	synthetic $\beta_{15\mu\text{m(c)}} \geq 1.000$
M15	synthetic $\beta_{20\mu\text{m(c)}} \geq 1.000$	
5. ELEMENT COLLAPSE	A	21 bar
	Y	21 bar - with ABF / RF valve
	B	210 bar
	X	210 bar - with ABF / RF valve
		not available for "M" media
6. SEALS	*B	NBR
*omitted for spare element	V	FKM (option)
7. CONNECTIONS	B5	G 1"
For different thread options please check availability with Filtrac Customer Service.	B6	G 1 1/4"
8. BYPASS VALVE	0	no by-pass
	D	6 bar
	L	3,5 bar (on request)
9. ABF VALVE / RF VALVE	0	no valve
ABF=anti back flow valve	C	ABF valve
RF= reverse flow valve	R	ABF valve+RF valve
10. INDICATOR PORT OPTION	S	upper differential indicator seat with metallic cap
	W	upper differential indicator seat with plastic cap

Continued on the next page

11. COMPULSORY FIELD	000	standard
12. CORROSION PROTECTION	S	standard
13. OPTION	0	no option

ACCESSORIES

The accessories must be ordered separately

INDICATOR

(F) digit for FKM seal option

*LC24=Led connector

For other options see clogging indicators catalogue

V02 (VF2)	differential visual 2,7 bar	
E02 (EF2)	differential electrical 2,7 bar	
E02L (EF2L)	differential electric 2,7 bar + *LC24	
VEF2	differential visual and electric 2,7 bar	
V05 (VF5)	differential visual 5 bar	
E05 (EF5)	differential electrical 5 bar	
E05L (EF5L)	differential electric 5 bar + *LC24	
VEF5	differential visual and electric 5 bar	
V08 (VF8)	differential visual 8 bar	
E08 (EF8)	differential electrical 8 bar	recommended for no by-pass option
E08L (EF8L)	differential electric 8 bar + *LC24	
VEF8	differential visual and electric 8 bar	

HYDRAULIC SYMBOLS

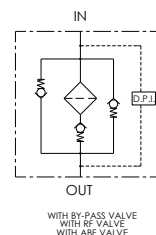
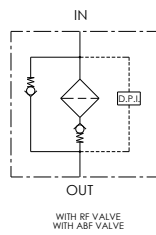
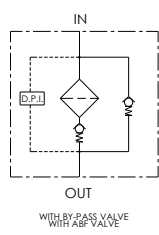
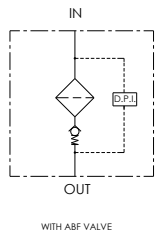
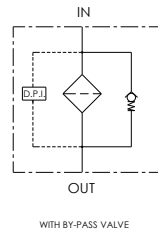
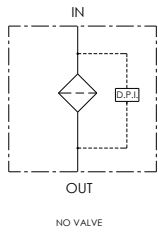

PRESSURE DROP (Δp) INFORMATION FOR FILTER SIZING

The total Delta P through a filter assembly is given from Housing Δp + Element Δp .

This ideally should not exceed 1,0 bar and should never exceed 1/3 of the set value of the by-pass valve. N.B. All the reported data have been obtained at our laboratory, according to specification ISO3968 with mineral oil having 32 cSt viscosity and density 0,875 Kg/dm³.

HOUSING PRESSURE DROP

The housing Δp is given by the curve of the considered model and port, in correspondence of the flow rate value.

FH100 D1-3x

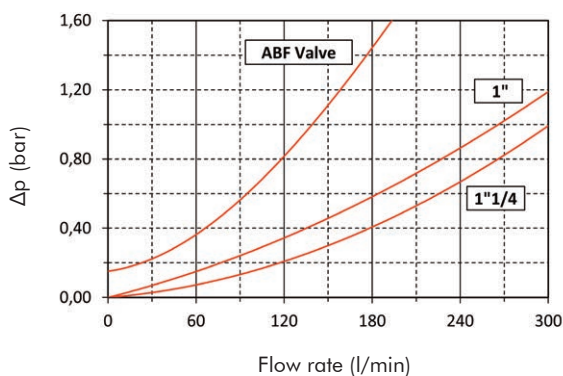

RF VALVE

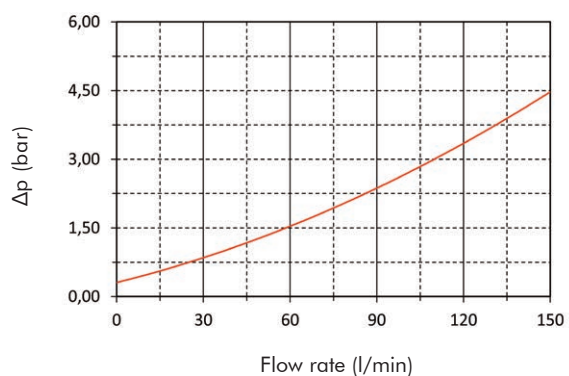

ELEMENT PRESSURE DROP (filter elements 21 bar collapse)

The element Δp (bar) is given by the flow rate (l/min) multiplied by the factor in the table here below corresponding to the selected media and divided by 1000.

If the oil has a viscosity V_x different than 32 cSt a corrective factor $V_x/32$ must be applied.

Example: 90 l/min with D136G10A and oil viscosity 46 cSt: $(90 \times 3,71)/1000 \times (46/32) = 0,48$ bar

	G01	G03	G06	G10	G15	G25	M05	M10	M15
D135	15,82	11,07	7,27	4,45	3,03	2,87	3,11	2,36	1,58
D136	13,19	9,23	6,06	3,71	2,53	2,39	2,59	1,97	1,32
D137	9,63	6,74	4,43	2,71	1,85	1,75	1,89	1,44	0,96

EXAMPLE OF TOTAL Δp CALCULATION

FH100D136G10ABB5D0S000S0 with **90** l/min and oil **46** cSt:

Housing Δp 0,25 bar + element Δp 0,48 bar: $(90 \times 3,71)/1000 \times (46/32) =$ total assembly Δp 0,73 bar

ELEMENT PRESSURE DROP (filter elements 210 bar collapse)

The element Δp (bar) is given by the flow rate (l/min) multiplied by the factor in the table here below corresponding to the selected media and divided by 1000.

If the oil has a viscosity V_x different than 32 cSt a corrective factor $V_x/32$ must be applied.

Example: 90 l/min with D136G10B and oil viscosity 46 cSt: $(90 \times 4,72)/1000 \times (46/32) = 0,61$ bar

	G01	G03	G06	G10	G15	G25
D135	20,27	14,19	9,50	5,66	4,01	3,41
D136	16,90	11,83	7,92	4,72	3,34	2,84
D137	12,35	8,64	5,79	3,45	2,44	2,07

EXAMPLE OF TOTAL Δp CALCULATION

FH100D136G10ABB5D0S000S0 with **90** l/min and oil **46** cSt :

Housing Δp 0,25 bar + element Δp 0,61 bar: $(90 \times 4,72)/1000 \times (46/32) =$ total assembly Δp 0,86 bar

BYPASS VALVE PRESSURE DROP

The bypass valve Δp is given by the curve of the considered model and setting, in correspondence of the flow rate value.

FH100 D13x

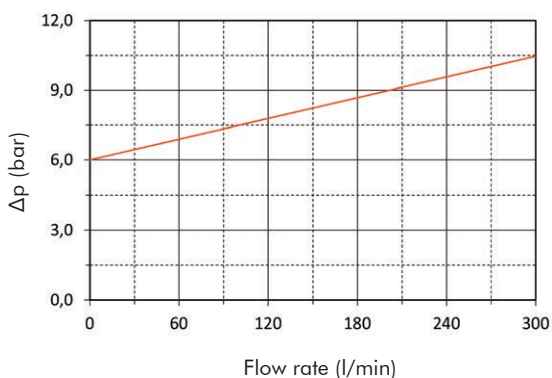

N.B. All the reported data have been obtained at our laboratory, according to specification ISO3968 with mineral oil having 32 cSt viscosity and density 0,875 Kg/dm³.

USER TIPS



- 1 FILTER HEAD
- 2 INDICATOR PORT
- 3 FIXING HOLES
- 4 FILTER ELEMENT
- 5 SEAL KIT
- 6 FILTER BOWL
- 7 IDENTIFICATION LABEL

INDICATOR TIGHTENING TORQUE

90 Nm

SPARE SEAL KIT PART NUMBER (5)

	NBR	FKM
FH100 D1-3x	06.021.00270	06.021.00271

BOWL TIGHTENING TORQUE

screw up filter bowl till end



WARNING

-  Make sure that Personal Protective Equipment (PPE) is worn during installation and maintenance operation.

DISPOSAL OF FILTER ELEMENT

-  The used filter elements and the filter parts dirty of oil are classified as "Dangerous waste material": they must be disposed according to the local laws by authorized Companies.



INSTALLATION

-  1. The IN and OUT ports must be connected to the hoses in the correct flow direction, an arrow shows on the filter head (1).
- 2. The filter housing should be preferably mounted with the bowl (6) downward.
- 3. Secure to the frame the filter head (1) using the threaded fixing holes (3).
- 4. Verify that no tension is present on the filter after mounting.
- 5. Enough space must be available for filter element replacement.
- 6. The visual clogging indicator must be in an easily viewable position.
- 7. When an electrical indicator is used, make sure that it is properly wired.
-  8. Never run the system with no filter element fitted.
- 9. Keep in stock a spare FILTREC filter element for timely replacement when required.
- 10. Filter housing should be earthed.

OPERATION

-  1. The filter must work within the operating conditions of pressure, temperature and compatibility given in the first page of this data sheet.
- 2. The filter element must be replaced as soon as the clogging indicator signals at working temperature (in cold start conditions, oil temperature lower than 30°C, a false alarm can be given due to oil viscosity).
- 3. If no clogging indicator is mounted, replace the element according to the system manufacturer's recommendations.

MAINTENANCE

-  1. Make sure that the system is switched off and there is no residual pressure in the filter.
- 2. Unscrew the bowl (6) by turning it anti-clockwise and remove it.
- 3. Remove the dirty element (4).
- 4. Fit a new FILTREC element (4), verifying the part number, particularly concerning the micron rating; open its plastic protection on the open-end side and insert it onto the spigot in the filter head, then remove completely the plastic protection.
- 5. Clean the bowl carefully; check condition of O-rings (5) and replace them if necessary.
- 6. Lubricate the bowl's thread (6) and screw it by hand into the filter head (1) by turning it clockwise.
- 7. Screw in the bowl to stop.
-  8. The used filter elements cannot be cleaned and re-used.

