

DSE5J

DIRECTIONAL VALVE WITH PROPORTIONAL CONTROL FEEDBACK AND INTEGRATED ELECTRONICS

SERIES 30

SUBPLATE MOUNTING
ISO 4401-05

p max **320** bar
Q max **180** l/min

MOUNTING INTERFACE

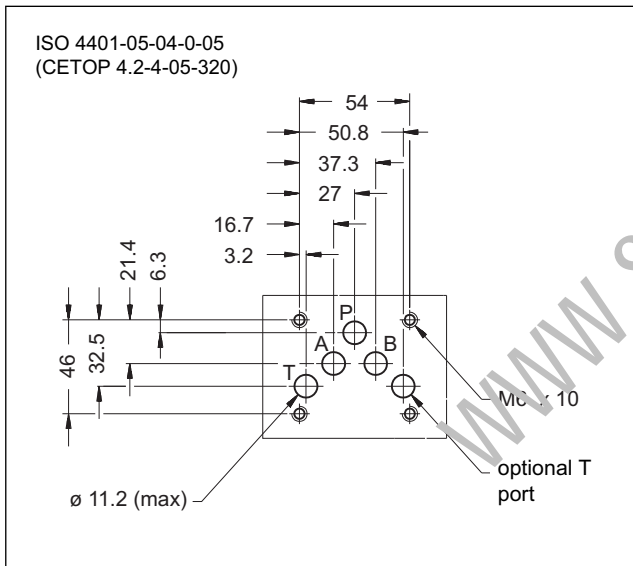

PERFORMANCES

(Obtained with mineral oil with viscosity of 36 cSt at 50°C and p = 140 bar)

Max operating pressure: - P - A - B ports - T port	bar	320 210
Nominal flow with Δp 10 bar P-T	l/min	50 - 75
Response times	see paragraph 7	
Hysteresis	% of Q max	< 0,2%
Repeatability	% of Q max	< \pm 0,1%
Threshold		< 0,1%
Valve reproducibility		\leq 5%
Electrical characteristics, IP	see paragraph 3	
Ambient temperature range	°C	-20 / +60
Fluid temperature range	°C	-20 / +80
Fluid viscosity range	cSt	10 + 400
Fluid contamination degree	according to ISO 4406:1999 class 18/16/13	
Recommended viscosity	cSt	25
Mass: single solenoid valve double solenoid valve	kg	5,6 7,1

OPERATING PRINCIPLE

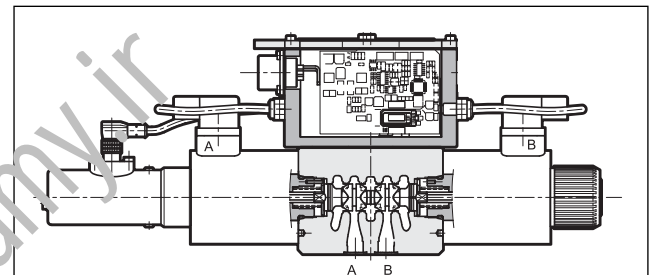

- The DSE5J is a direct operated directional valve with electric proportional control, on-board electronics and feedback, with mounting interface in compliance with ISO 4401 standards.
- It is used to control the direction and the speed of hydraulic actuators.
- Transducer and digital card allow a fine control of the positioning of the cursor, reducing hysteresis and response time and optimizing the performance of the valve.
- The valves are available with command signal in voltage or current and on board electronics with internal enable, external enable or 0V monitor on pin C.
- The monitoring of the spool position is available on pin F.
- The valve is easy to install. The driver directly manages digital settings (see par. 6). In the event of special applications, you can customize the settings using the optional kit (see par. 11).

HYDRAULIC SYMBOLS (typical)

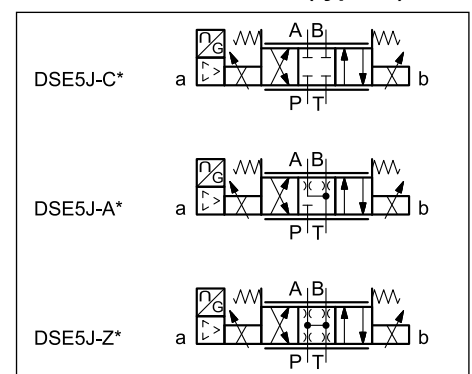

1 - IDENTIFICATION CODE

D	S	E	5	J	-						/	30	-	K11	
---	---	---	---	---	---	--	--	--	--	--	---	----	---	-----	--

Direct operated directional control valve

Electric proportional control

Size ISO 4401-05

Digital integrated electronics for valves with feedback

Spool type:
C = closed centres
A = open centres
Z = zero overlap

Nominal flow rate of the spool (see par. 2)

FS = Fail safe option. (omit if not required).

Pin C function:
A = external enable
B = internal enable
C = 0V monitor

Main connector 6 pin + PE

Reference signal:
E0 = voltage $\pm 10V$
E1 = current $4 \pm 20mA$

Seals:
N = NBR seals for mineral oil (**standard**)
V = FPM seals for special fluids

Series N. (the overall and mounting dimensions remain unchanged from 30 to 39)

Solenoid position (omit for 2 solenoids configuration):
SA = 1 solenoid on side A

2 - CONFIGURATIONS

The valve configuration depends on the combination of the following elements:
 number of proportional solenoids, spool type, rated flow.

Configuration 2 solenoids :
3 positions with spring centering

Configuration 1 solenoid on side A "SA":
2 positions (central + external) with spring centering

3 - ELECTRICAL CHARACTERISTICS

3.1 - Electrical on board electronics

Duty cycle		100% (continuous operation)
Protection class according to EN 60529		IP65 / IP67
Supply voltage	V DC	24 (from 19 to 30 VDC), ripple max 3 Vpp
Power consumption	VA	40
Maximum solenoid current	A	2.8
Fuse protection, external		3A
Command signals: voltage (E0) current (E1)	V DC mA	± 10 (Impedance $R_i > 11$ kOhm) $4 \div 20$ (Impedance $R_i = 58$ Ohm)
Monitor signals: voltage (E0) current (E1)	V DC mA	± 10 (Impedance $R_o > 1$ kOhm) $4 \div 20$ (Impedance $R_o = 500$ Ohm)
Managed breakdowns		Overload and electronics overheating, LVDT sensor error, cable breakdown, supply voltage failure
Communication		LIN-bus Interface (with the optional kit)
Connection		7 - pin MIL-C-5015-G (DIN-EN 175201-804)
Electromagnetic compatibility (EMC) emissions EN 61000-6-4 immunity EN 61000-6-2		According to 2004/108/EC standards

3.2 - On-board electronics diagrams

VERSION A - External Enable

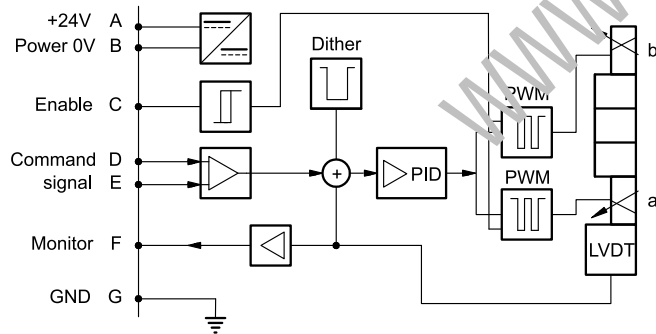

VERSION B - Internal Enable

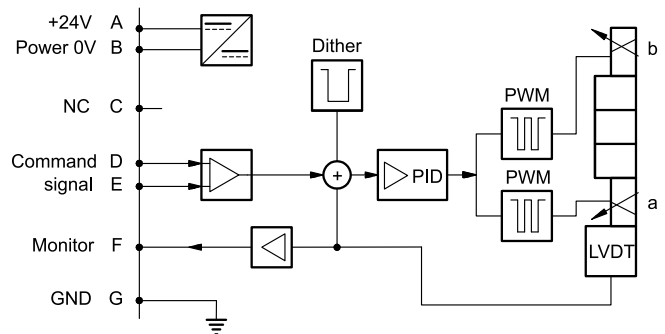

VERSION C - 0V Monitor

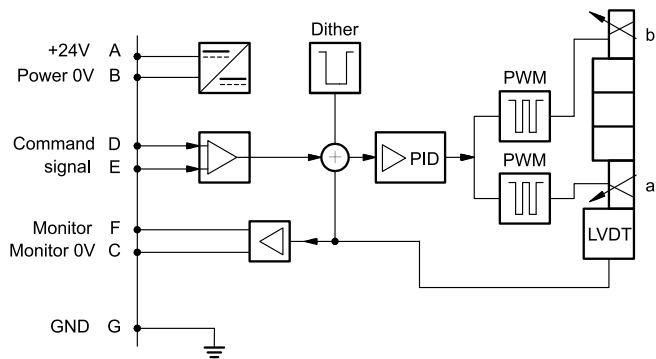

4 - VERSIONS WITH VOLTAGE COMMAND (E0)

The reference signal is between -10V and +10V on double solenoid valve, and 0...10V on single solenoid valves SA. The monitor feature of versions B and C becomes available with a delay of 0,5 sec from the power-on of the card.

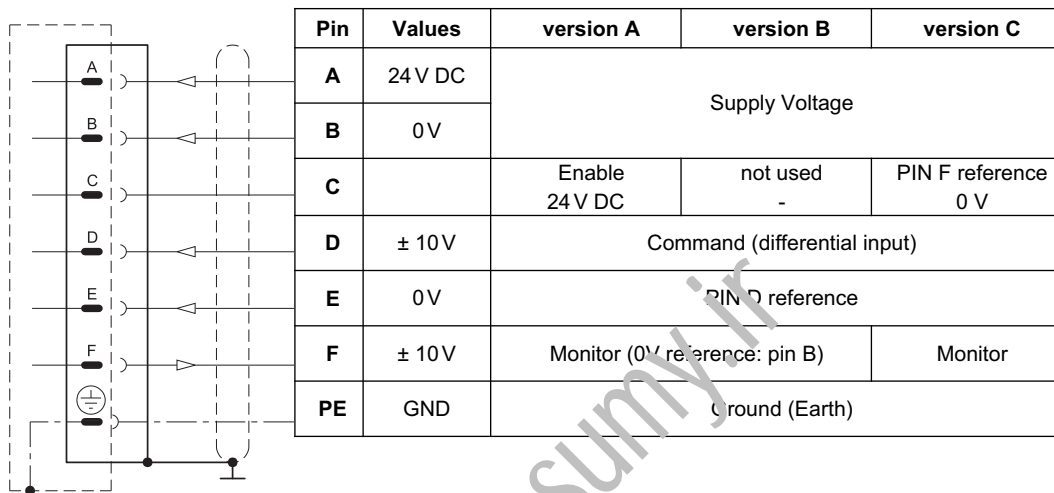
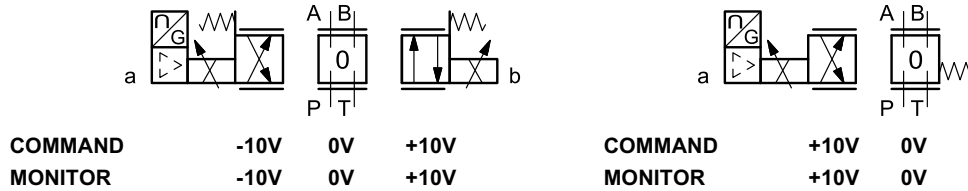

5 - VERSIONS WITH CURRENT COMMAND (E1)

The reference signal is supplied in current $4 \div 20$ mA. If the current for command is lower the card shows a breakdown cable error. To reset the error is sufficient to restore the signal.

The monitor feature of versions B and C becomes available with a delay of 0,5 sec from the power-on of the card.

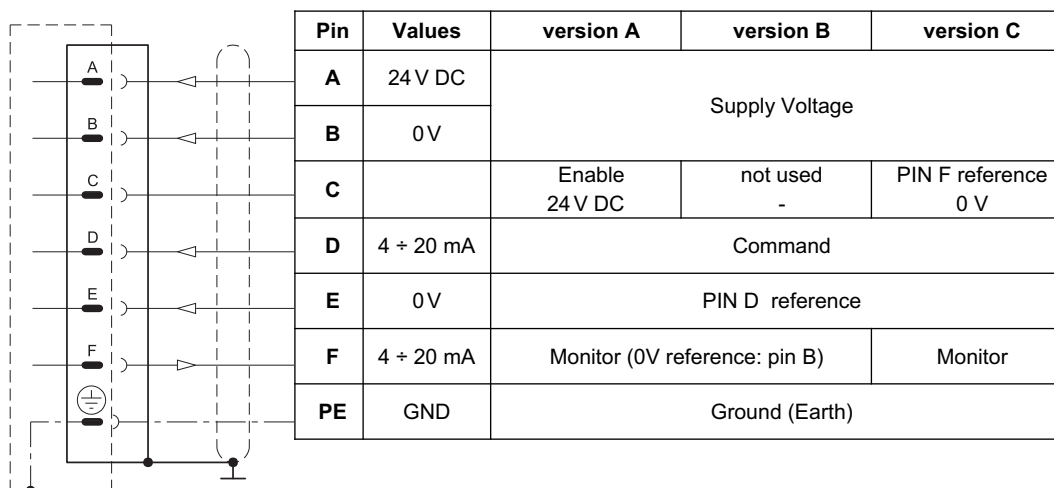
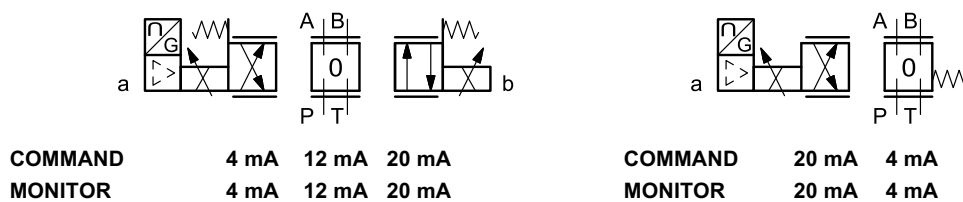

6 - CHARACTERISTIC CURVES

(obtained with mineral oil with viscosity of 36 cSt at 50°C and $p = 140$ bar)

Typical flow rate curves at constant Δp related to the reference signal and measured for the available spools. The Δp values are measured between P and T valve ports.

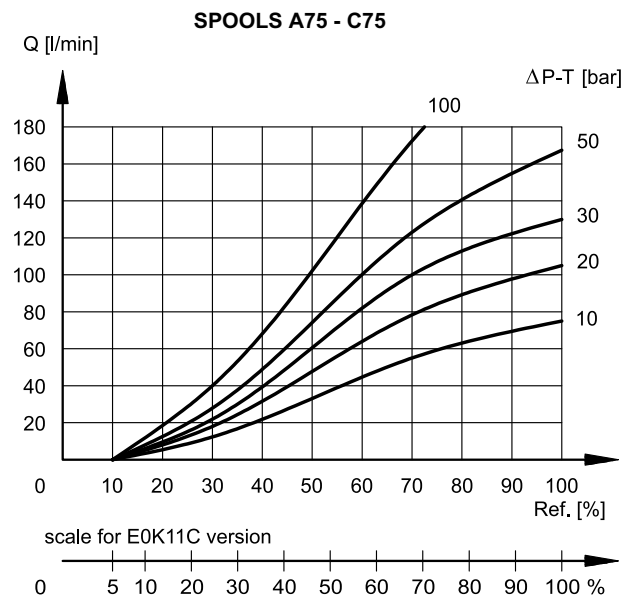
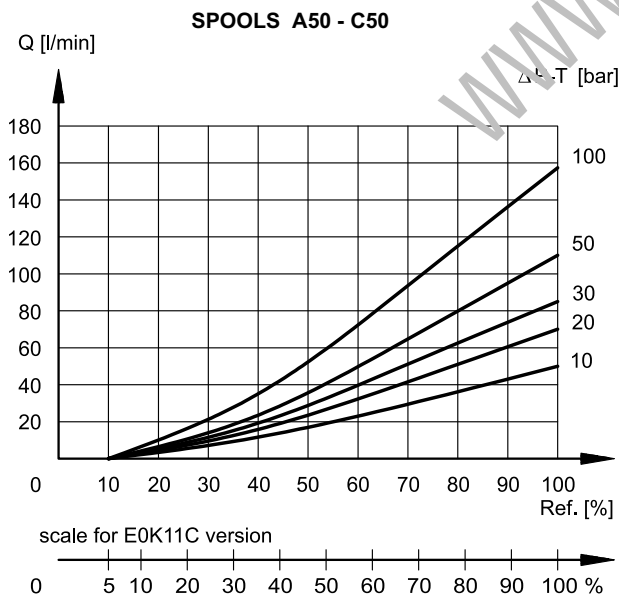
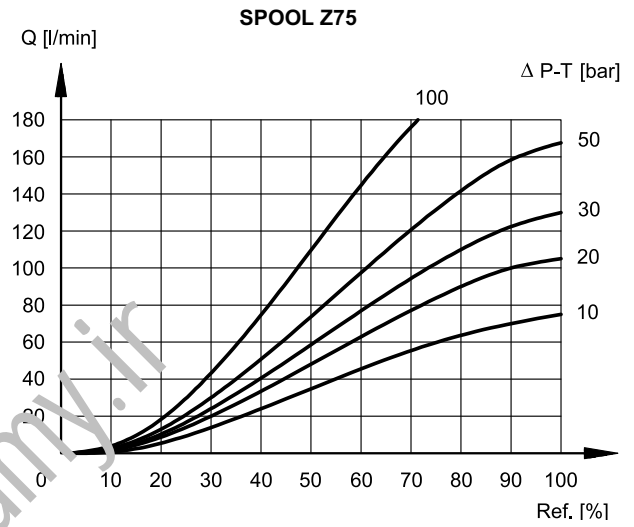
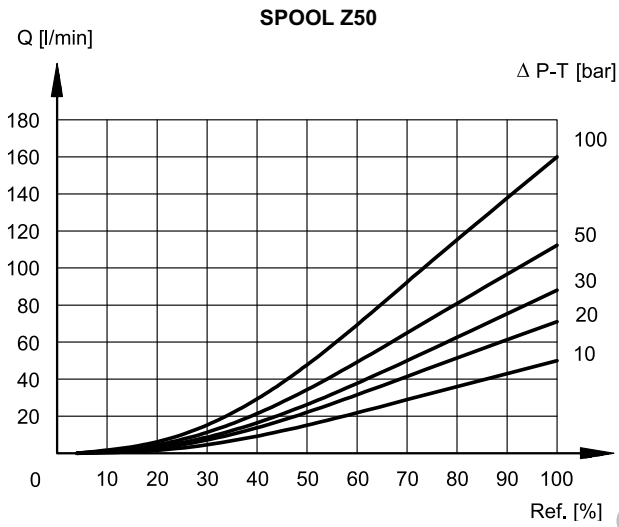
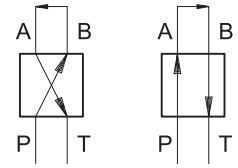

Z*FS SPOOLS - FAIL SAFE FEATURE

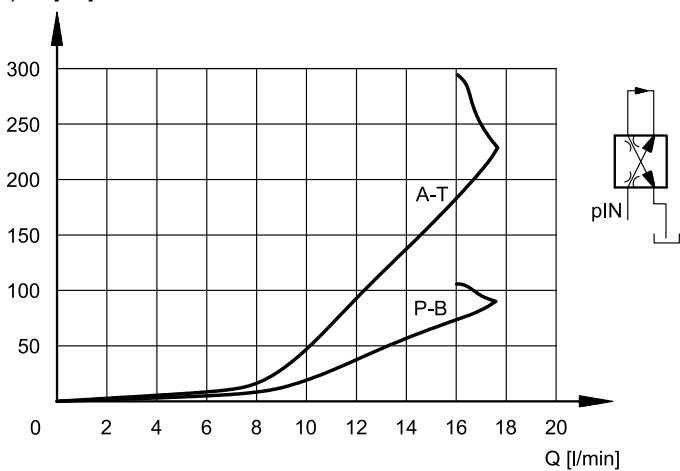

Flow P→B / A→T with valve in fail safe position, depending on the incoming pressure.

When a power failure (enabling OFF) occurs, the valve moves in 'fail safe' position by maintaining a minimum flow that allows the actuator to return slowly to a safety position.

During the black-out the centering springs retain the spool in fail safe-position.

Z SPOOLS - PRESSURE GAIN

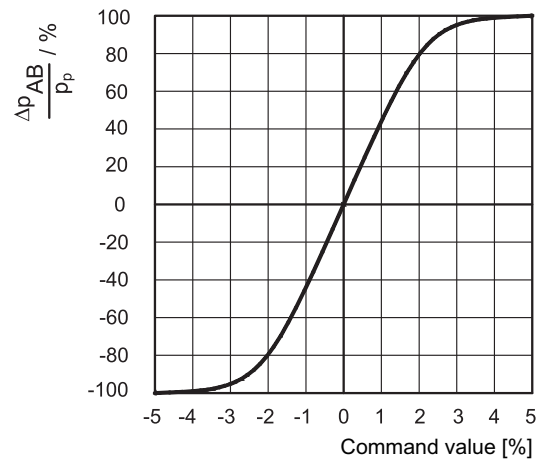

The diagram shows the valve pressure gain, expressed as % of the ratio between the port pressure variation in A or B (Δp_{AB}) and the P system pressure, according to the reference signal.

In practice, the pressure gain states the valve reaction towards external disturbances aimed at changing the actuator position.

7 - RESPONSE TIMES

(obtained with mineral oil with viscosity of 36 cSt at 50°C 140 bar $\Delta p_{P \rightarrow T}$)

FREQUENCY RESPONSE (SPOOL Z - 4/3 valve)

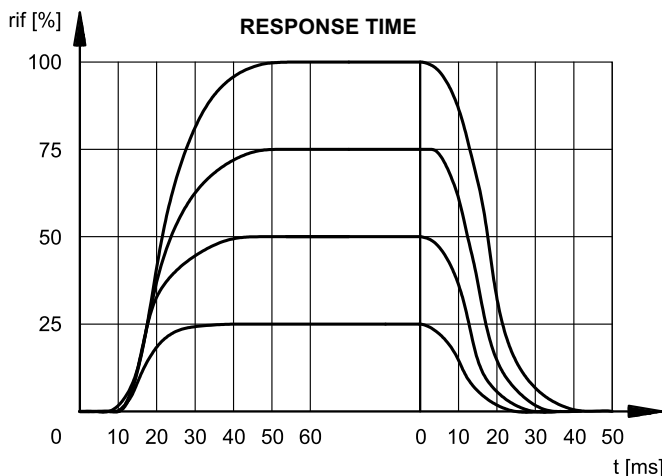
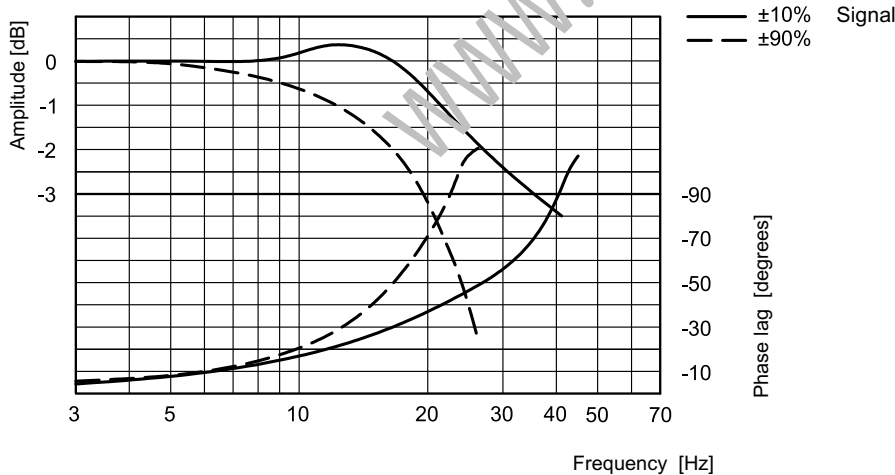

8 - OVERALL AND MOUNTING DIMENSIONS

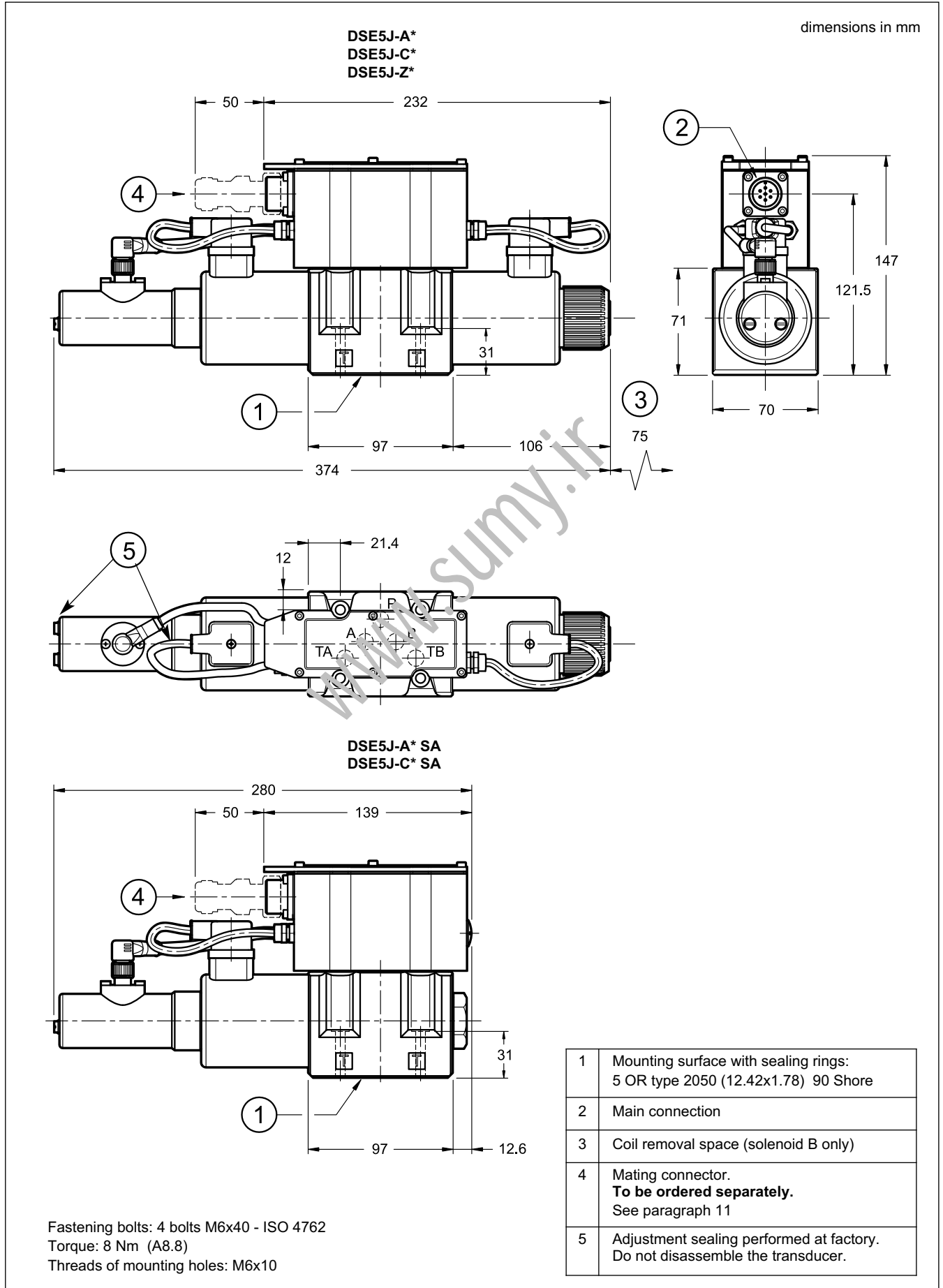

9 - HYDRAULIC FLUIDS

Use mineral oil-based hydraulic fluids HL or HM type, according to ISO 6743-4. For these fluids, use NBR seals. For fluids HFDR type (phosphate esters) use FPM seals (code V). For the use of other kinds of fluid such as HFA, HFB, HFC, please consult our technical department.

Using fluids at temperatures higher than 80 °C causes a faster degradation of the fluid and of the seals characteristics.

The fluid must be preserved in its physical and chemical characteristics.

10 - INSTALLATION

DSE5J valves can be installed in any position without impairing correct operation.

Ensure that there is no air in the hydraulic circuit.

Valves are fixed by means of screws or tie rods on a flat surface with planarity and roughness equal to or better than those indicated in the relative symbols. If minimum values are not observed, fluid can easily leak between the valve and support surface.

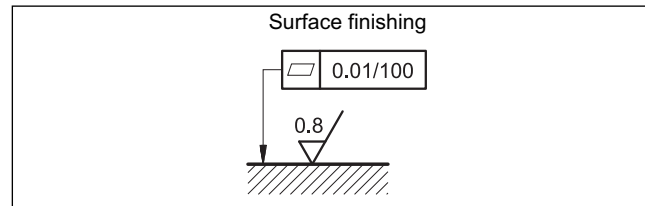

11 - ACCESSORIES

(to be ordered separately)

11.1 Mating connector

These valves have a plug for 7-pin mating connector, that is placed on the box of the integral motion control.



So as to avoid electromagnetic troubles and comply with the electromagnetic compatibility regulation EMC, it is recommended the use of a metal connector.

If a plastic connector is used, make sure that the protection characteristics IP and EMC of the valve are guaranteed.

Duplomatic can provide a metal cable connector type MIL-C-5015-G (EN 175201-804).

name: **EX7S/L/10** code **3890000003**

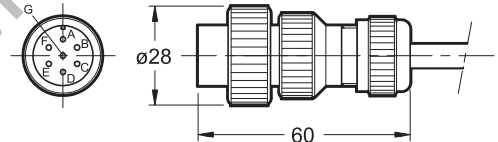

11.2 - Connection cables size

Power supply:

- up to 20 m cable length : 1,0 mm²
- up to 40 m cable length : 1,5 mm²

Signal: 0,50 mm²

A suitable cable would have 7 isolated conductors, a separate screen for the signal wires and an overall screen.

11.3 - Kit for start-up LINPC-USB

Device for service start-up and diagnostic, see catalogue 89850.

12 - SUBPLATES

(see catalogue 51 000)

PMD4-AI4G rear ports 3/4" BSP
PMD4-AL4G side ports 1/2" BSP