

CHECK VALVES POPPET TYPE

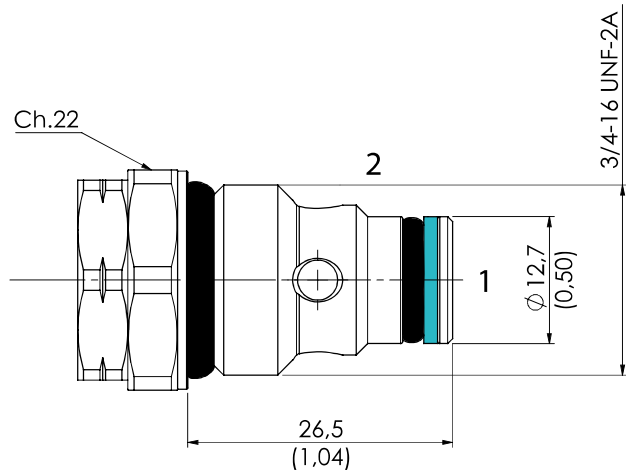

mm
[Inches]

HYDRAULIC CIRCUIT



PERFORMANCES

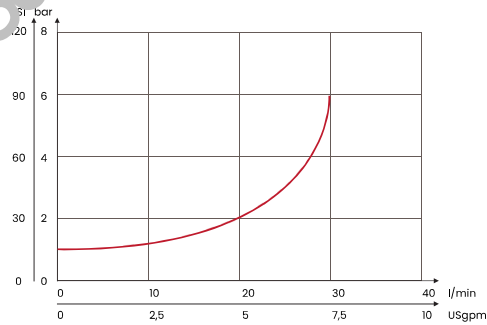

ORDERING CODE

ORDERING CODE	CAVITY	SPRING	MAX FLOW l/min USgpm	MAX PRESSURE bar PSI	TIGHTENING TORQUE Nm lbt ft	WEIGHT kg lbt
UC205	SAE8/2	0,5 bar [7,3 PSI]	25 [6,6]	350 [5075]	30 [22]	0,06 [0,13]
UC230		3 bar [43,5 PSI]				
UC245		4,5 bar [65,5 PSI]				

Mineral oil: DIN 51524 ISO 6743/4 | Oil viscosity: 15 to 250 cSt 15-250 mm²/s | Oil temperature: -4°F + 176°F -20°C +80°C | Ambient temperature: -4°F + 122°F -20°C +50°C | Max contamination index with filter: 5 to 250 cSt 15-250 mm²/s | It is necessary a filter use to protect the valve (advised filtration 15 µm) | Max leakage: 0,25 cm³/min - 5 drops/min