

# DS3JB

## SOLENOID OPERATED DIRECTIONAL CONTROL VALVE

**AC**  
**SERIES 10**

**SUBPLATE MOUNTING**  
**NFPA D03 (ISO 4401-03)**

**p** max **5000** psi (350 bar)  
**Q** max **20** GPM (76 l/min)

### MOUNTING SURFACE

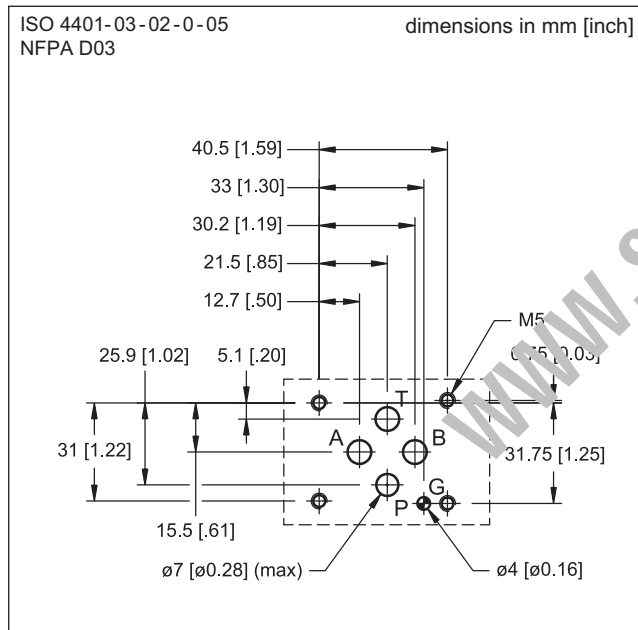

### OPERATING PRINCIPLE

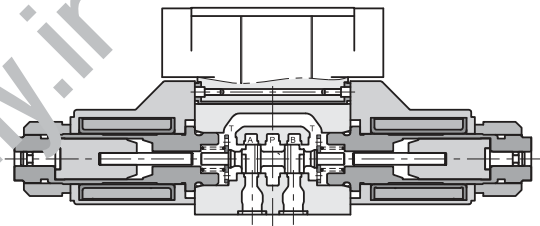

- Direct acting, subplate mounting directional control valve, with mounting surface according to NFPA D03 standards.
- The valve is supplied with 3 or 4 ports designs, with 2 or 3 positions with a wide range of spools.
- The valve body is made with high strength iron castings provided with wide internal passages in order to minimize the flow pressure drop. Wet armature solenoids with interchangeable coils are used (for further information on solenoids see par. 7).
- The valve is equipped with junction box to be wired.
- The valve is available with AC solenoids.
- A boot protected manual override is available for applications in tropical climate.

### PERFORMANCES

(obtained with mineral oil with viscosity of 170 SUS at 50°C)

Maximum operating pressure: - P - A - B ports - T port	psi	5000 2300
Maximum flowrate	GPM	20
Electrical connection	junction box	
Ambient temperature range	°F	-4 / +122
Fluid temperature range	°F	-24 / +176
Fluid viscosity range	SUS	60 ÷ 1900
Fluid contamination degree	according to ISO 4406:1999 class 20/18/15	
Recommended viscosity	SUS	120
Mass: single solenoid valve dual solenoid valve	lbs	3.15 4.15

## 1 - IDENTIFICATION CODE

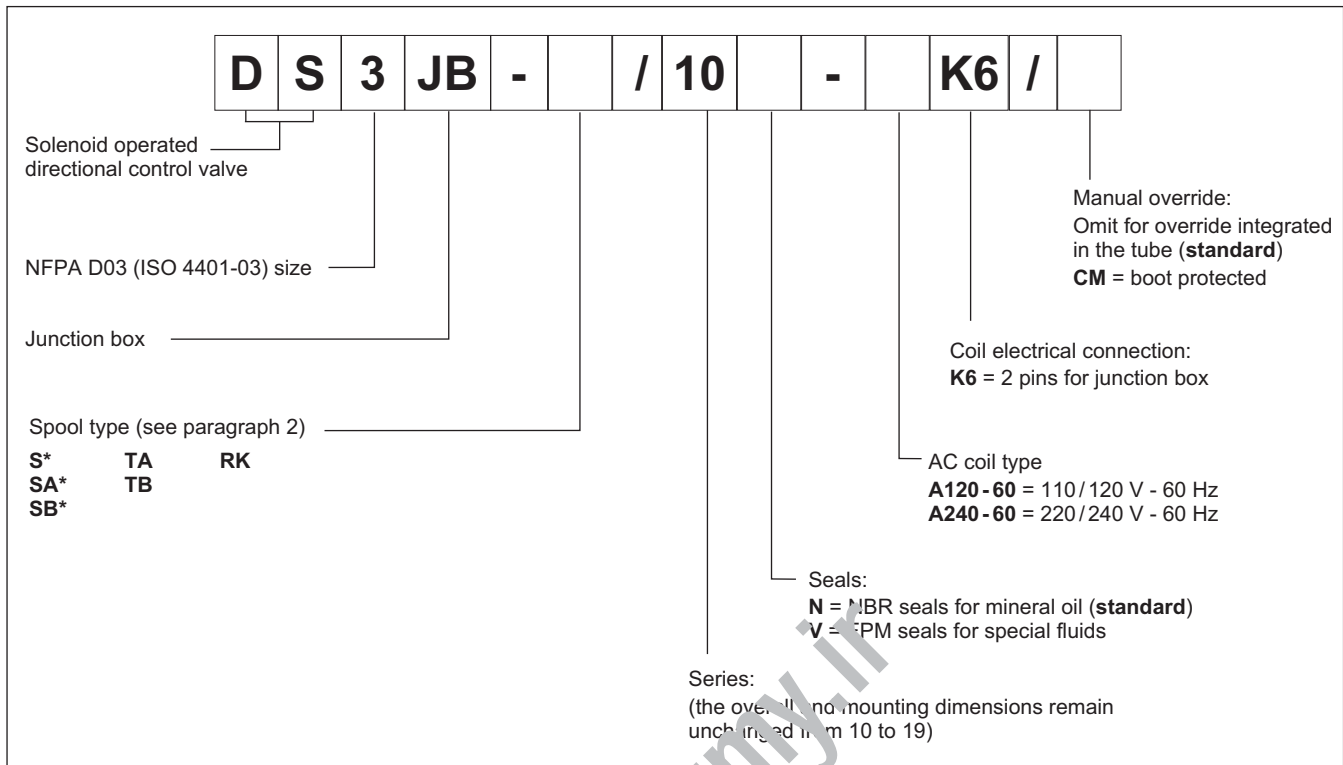

## 2 - SPOOL TYPE

Other spools are available on request.

**Type S\*:**  
2 solenoids - 3 positions  
with spring centering

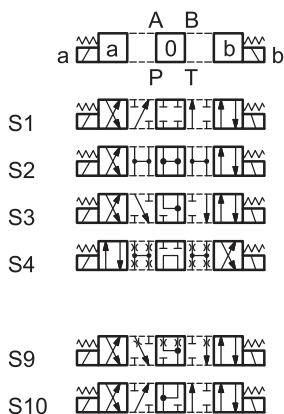

**Type SA\*:**  
1 solenoid side A  
2 positions (central + external)  
with spring centering



**Type SB\*:**  
1 solenoid side B  
2 positions (central + external)  
with spring centering

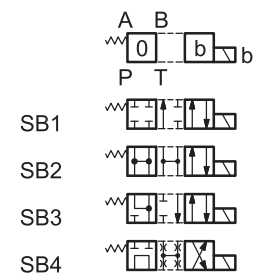

**Type TA:**  
1 solenoid side A  
2 external positions  
with return spring

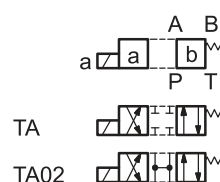

**Type TB:**  
1 solenoid side B  
2 external positions  
with return spring

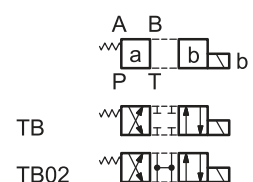

**Type RK:**  
2 solenoids - 2 positions  
with mechanical retention

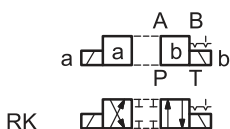



### 3 - HYDRAULIC FLUIDS

Use mineral oil-based hydraulic fluids HL or HM type, according to ISO 6743-4. For these fluids, use NBR seals (code N). For fluids HFDR type (phosphate esters) use FPM seals (code V). For the use of other fluid types such as HFA, HFB, HFC, please consult our technical department. Using fluids at temperatures higher than 176 °F causes a faster degradation of the fluid and of the seals characteristics. The fluid must be preserved in its physical and chemical characteristics.

### 4 - PRESSURE DROPS $\Delta p$ -Q

(obtained with viscosity 170 SUS at 122 °F)

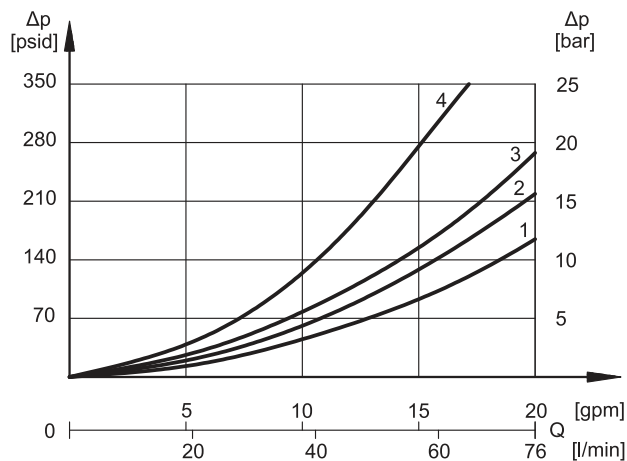

When spool S10 is used for regenerative circuits, pressure drops between A and B lines are described by curve 4 .

#### PRESSURE DROPS WITH VALVE IN ENERGIZED POSITION

SPOOL TYPE	FLOW DIRECTION			
	P→A	P→B	A→T	B→T
	CURVES ON GRAPH			
S1, SA1, SB1	2	2	3	3
S2, SA2, SB2	1	1	3	3
S3, SA3, SB3	3	3	1	1
S4, SA4, SB4	4	4	4	4
S9	2	2	3	3
S10	1	3	1	3
T1, TB	3	3	3	3
T102, T102	2	2	2	2
RK	2	2	2	2

#### PRESSURE DROPS WITH VALVE IN DE-ENERGIZED POSITION

SPOOL TYPE	FLOW DIRECTION				
	P→A	P→B	A→T	B→T	P→T
	CURVES ON GRAPH				
S2, SA2, SB2					2
S3, SA3, SB3			3	3	
S4, SA4, SB4					3
S10	3	3			

### 5 - SWITCHING TIMES

The values indicated are obtained according to ISO 6403 standard. They refer to an S1 solenoid valve for Q = 10 GPM, p = 2,000 psi working with mineral oil at a temperature of 122 °F, a viscosity of 170 SUS and with PA and BT connections.

The energizing times are obtained at the time the spool switches over. The de-energizing times are measured at the time pressure variation occurs on the line.

	ENERGIZING	DE-ENERGIZING
<b>TIMES (±10%) [ms]</b>	10 ± 25	15 ± 40



## 6 - OPERATING LIMITS

The curves define the flow rate operating fields according to the valve pressure.

The values have been obtained according to ISO 6403 standard, with mineral oil, viscosity 170 SUS, temperature 122 °F and filtration according to ISO 4406:1999 class 18/16/13, with solenoids at rated temperature and supplied with voltage equal to 90% of the nominal voltage.

**The limits for TA02 and TA spools refer to the 4-port operation. The operating limits can be considerably reduced if a 4-port valve is used as 3-port valve with port A or B plugged or without flow.**

Valves fed at 110 V / 60 Hz may have slightly lower performance limits than those showed in the diagram.

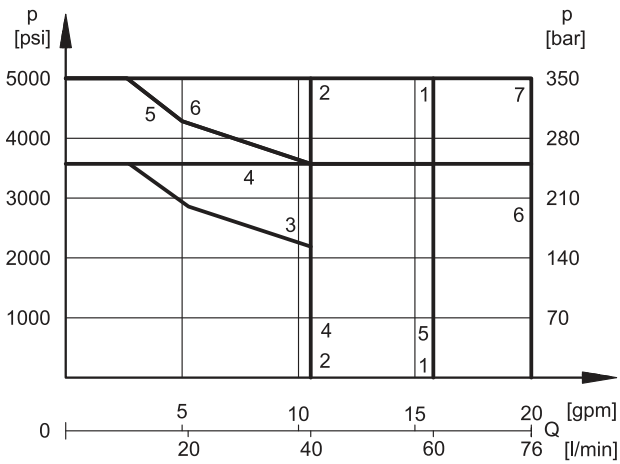

SPOOL	CURVE	
	P→A	P→B
S1, SA1, SB1	1	1
S2, SA2, SB2	2	2
S3, SA3, SB3	3	3
S4, SA4, SB4	1	1
S9	4	4
S10	1	1
TA, TB	5	5
TA02, TB02	6	6
RK	7	7

## 7 - ELECTRICAL FEATURES

### 7.1 Solenoids

These are essentially made up of two parts: tube and coil. The tube is threaded into the valve body and includes the armature that moves immersed in oil, without wear. The inner part, in contact with the oil in the return line, ensures heat dissipation.

The coil is fastened to the tube by a threaded nut.

The interchangeability of coils of different voltages is allowed.

<b>SUPPLY VOLTAGE FLUCTUATION</b>	± 10% Vnom
<b>MAX SWITCH ON FREQUENCY</b>	10.000 ins/hr
<b>DUTY CYCLE</b>	100%
<b>ELECTROMAGNETIC COMPATIBILITY (EMC)</b>	In compliance with 2004/108/EC
<b>LOW VOLTAGE</b>	In compliance with 2006/95/EC
<b>CLASS OF PROTECTION :</b> Class of protection IEC 60529 Coil insulation (VDE 0580) Impregnation:	IP65 class H class H

### 7.2 Current and absorbed power

The table shows current and power consumption values at inrush and at holding. In alternating current energizing, an initial phase (maximum movement) is seen, during which the solenoid consumes elevated value currents (inrush current); the current values diminish during the plunger stroke until it reaches the minimum values (holding current) when the plunger reaches the stroke end.

Coils (values ± 10%)

Suffix	Nominal Voltage [V]	Frequency [Hz]	Resistance at 20°C [Ohm]	Current consumption at inrush [A]	Current consumption at holding [A]	Power consumption at inrush [VA]	Power consumption at holding [VA]	Coil Code
<b>C20.6-A120-60K6/10</b>	110	60	27.5	1.8	0.36	198	39.6	1902820
	120			2	0.43	240	51.6	
<b>C20.6-A240-60K6/10</b>	220		0.86	0.17	189.2	37.4	1902821	
	240		0.98	0.2	235.2	48		

## 8 - INSTALLATION

Configurations with centering and return springs can be mounted in any position; type RK valves - without springs and with mechanical detent - must be mounted with the longitudinal axis horizontal.

Valve fixing takes place by means of screws or tie rods, with the valve mounted on a lapped surface, with values of planarity and smoothness that are equal to or better than those indicated in the drawing.

If the minimum values of planarity and/or smoothness are not met, fluid leakages between valve and mounting surface can easily occur.

## 9 - JUNCTION BOX

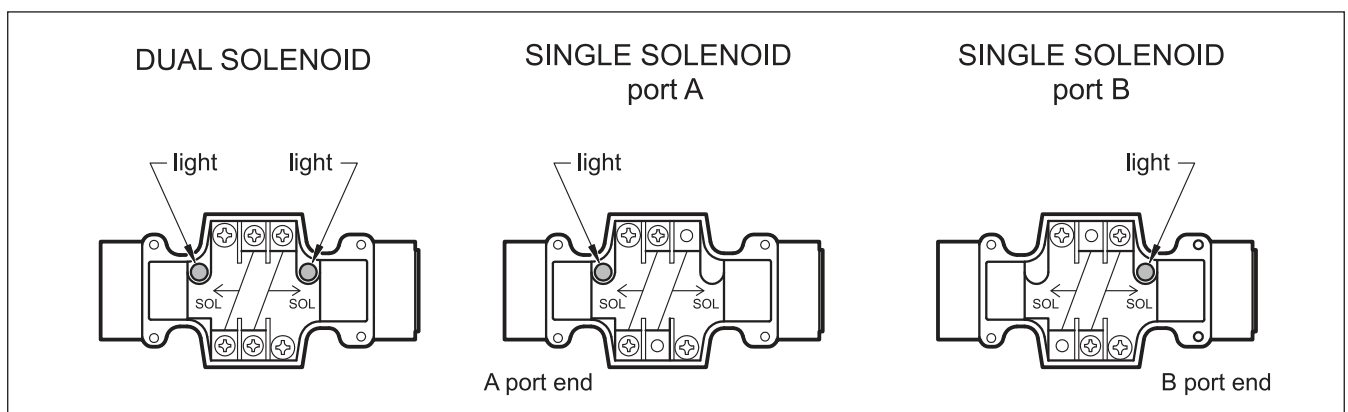
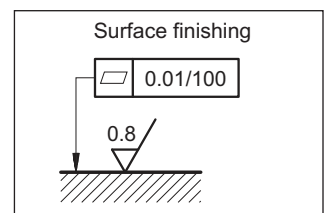



# DS3JB

## SERIES 10

### 10 - OVERALL AND MOUNTING DIMENSIONS

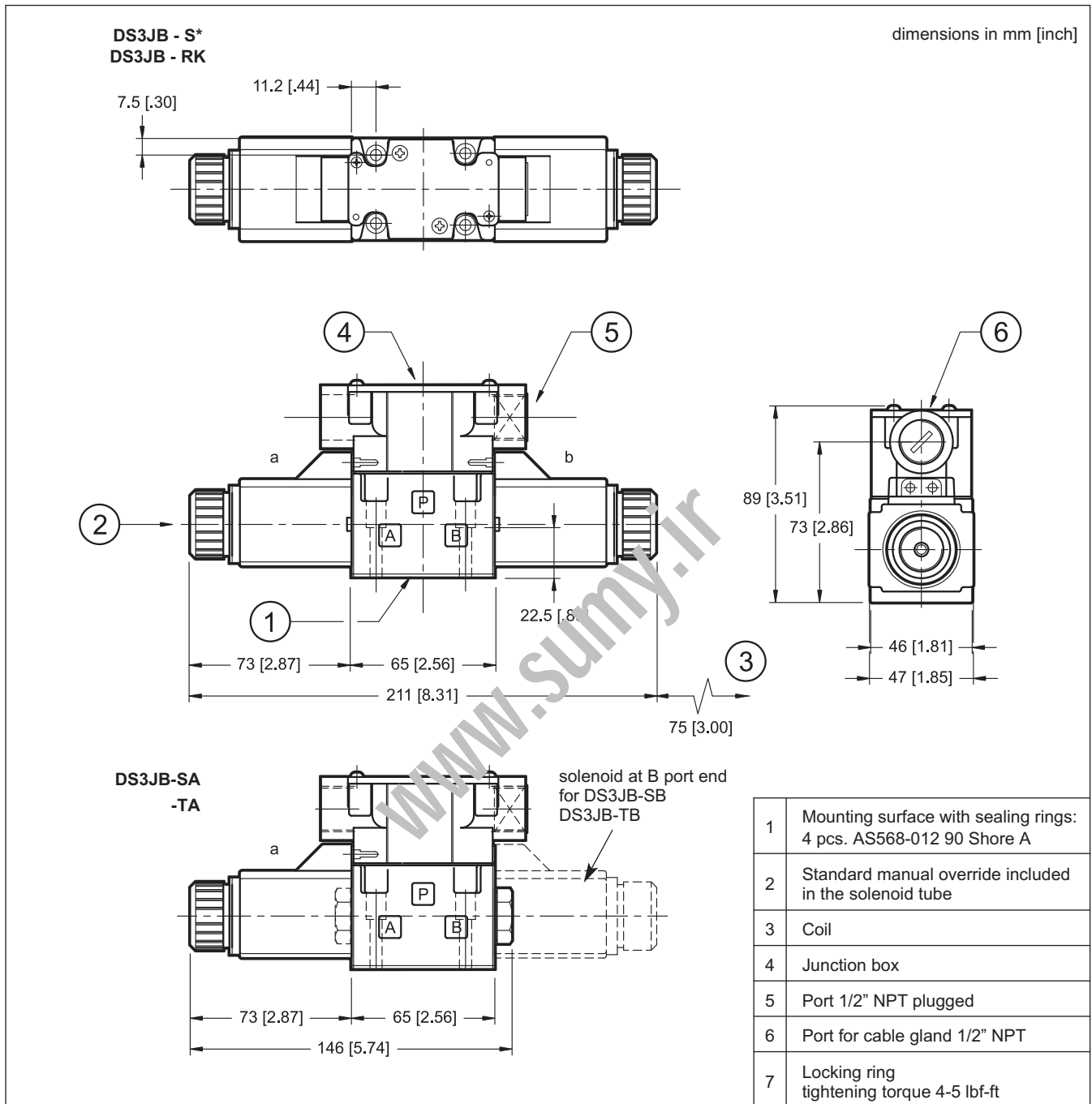

### 11 - CM MANUAL OVERRIDE

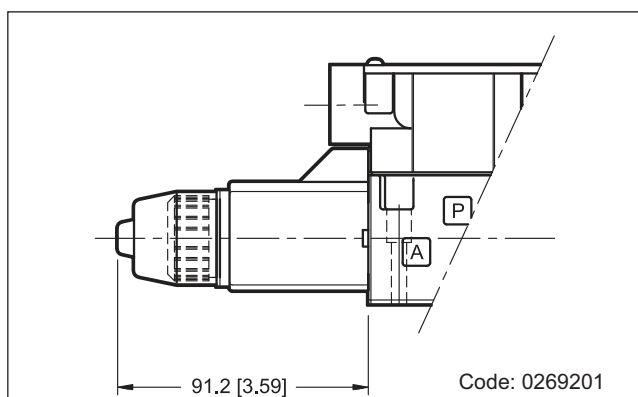

## 12 - SPARE PARTS

**COILS IDENTIFICATION CODE**

<b>C</b>	<b>20.6</b>	<b>-</b>	<b>K6</b>	<b>/</b>	<b>10</b>
----------	-------------	----------	-----------	----------	-----------

Supply voltage \_\_\_\_\_  
**A120-60** = 110/120 V - 60 Hz  
**A240-60** = 220/240 V - 60 Hz

Series no. (the overall and mounting dimensions remain unchanged from 10 to 19)

Coil electrical connection: 2 pins for junction box

**SEALS KIT**

The codes include the O-Ring nr. 5 and 6.

Cod. **1985406** NBR seals  
 Cod. **1985410** FPM (viton) seals

1	Coil locking ring cod. 0119333 Tightening torque 5 ±0.5 Nm
2	Spring washer code 0550483
3	Coil (see identification code at side)
4	Solenoid tube : TA20.6-DS3/10N (NBR seals) TA20.6-DS3/10V (FPM seals) <b>NOTE: OR n° 5 included</b>
5	AS568-016 70 Shore A
6	4 pcs. AS568-012 90 Shore A
7	Seal for junction box code 0119407
8	Junction box
9	2 pcs. Phillips screws M3x25

## 13 - FASTENING BOLTS

4 SHC M5x30 - ISO 4762 (or 10-24 UNC - 2Bx1.25)

Tightening torque 4-5 lbs.ft



# DS3JB

SERIES 10

[www.sumy.ir](http://www.sumy.ir)



**DIPLOMATIC OLEODINAMICA S.p.A.**  
20015 PARABIAGO (MI) • Via M. Re Depaolini 24  
Tel. +39 0331.895.111  
Fax +39 0331.895.339  
[www.diplomatic.com](http://www.diplomatic.com) • e-mail: [sales.exp@diplomatic.com](mailto:sales.exp@diplomatic.com)

