

DS(P)*M

DIRECTIONAL VALVES WITH SPOOL POSITION MONITORING

DS3M **ISO 4401-03**
DS5M **ISO 4401-05**

DSP5RM **ISO 4401-05**
DSP5M **CETOP P05**
DSP7M **ISO 4401-07**
DSP8M **ISO 4401-08**
DSP10M **ISO 4401-10**

OPERATING PRINCIPLE

— These solenoid operated directional valves are equipped with position sensors that monitor the main spool position. The switching position is indicated by a binary signal.

— TÜV certification body certifies the compliance of DS(P)*M valves with the EC safety standards ISO 4413:2012, UNI EN 12622:2014, UNI EN 693:2001 +A2:2001, UNI EN201:2010 and UNI EN 422:2009 with certificate TÜV IT 14 MAC 0043 .

— The valves are available in direct current versions only (see paragraph 8).

— These valves do not have manual override and can not be disassembled, because of their characteristics and their possible use on machinery subject to safety requirements. Moreover, their components are not interchangeable. Read the *Use and Maintenance manual* for instructions on operation, safe use and repair of the product

PERFORMANCES

(working with mineral oil of viscosity of 36 cSt at 50°C)

		DS3M	DS5M	DSP5M DSP5RM	DSP7M	DSP8M	DSP10M
Maximum operating pressure: P - A - B ports	bar	350	320	320	350	350	350
T port		210		see performance limits at paragraph 5.5			
Maximum flow rate from P to A - B - T	l/min	80	120	150	300	600	1100
Ambient temperature range	°C	-20 / +50					
Fluid temperature range	°C	-20 / +80					
Fluid viscosity range	cSt	10 + 400					
Fluid contamination degree		According to ISO 4406:1999 class 20/18/15					
Recommended viscosity	cSt	25					
Mass: single solenoid valve	kg	1,8	5	7,1	8,7	15,6	50
double solenoid valve		2,2	-	8	9,6	16,6	50.5

MACHINE DIRECTIVE CERTIFICATION

All solenoid valves and solenoid operated valves of the DS(P)*M family were tested on a voluntary basis by TÜV and found to comply with the applicable requirements of the following standards:

- UNI EN ISO 4413:2012 - Hydraulic fluid power – General rules and safety requirements for systems and their components
- UNI EN 12622:2014 - Safety of machine tools - Hydraulic press brakes
- UNI EN 693:2001+A2:2011 - Machine tools – Safety – Hydraulic presses
- UNI EN 201:2010 - Plastics and rubber machines - Injection moulding machines - Safety requirements
- UNI EN 422:2009 - Rubber and Plastic machines – Safety requirements



1 - IDENTIFICATION OF SOLENOID VALVES DIRECT OPERATED

1.1 - Identification code

D	S		M	-		/		-		K1	/	
----------	----------	--	----------	----------	--	----------	--	----------	--	-----------	----------	--

Directional control valve solenoid operated

3 = ISO 4401-03 size
5 = ISO 4401-05 size

Monitoring of the spool position

Spool type (see par. 1.2)

S1	SA1	SB1	TA	TB
S3			TA02	TB02
S4	SA4	SB4	TA100	TB100

Series No.
20 = for DS5M
21 = for DS3M
(the overall and mounting dimensions remain unchanged from 20 to 29)

Seals:
N = NBR seals for mineral oil (**standard**)
V = FPM seals for special fluids

Monitored position:
(see par. 16 for switching logic)

R0 = monitored rest position
MA = monitored position 'a'
MB = monitored position 'b'

Coil electrical connection:
plug for connector type
DIN 43650 (**standard**)

DC power supply

D12 = 12 V	D110 = 110 V
D24 = 24 V	D220 = 220 V

NOTE: To be compliant with the EN 693:2011 standard, the valves have no manual override.

NOTE: Verify spool and sensor type availability in the tables below

DS3		SPOOLS				
		S*	SA*	SB*	TA TA100	TB TB100
SENSOR TYPE	R0	x				
	MA		x	x	x	x
	MB		x	x	x	x

DS5		SPOOLS				
		S*	SA*	SB*	TA TA100	TA02 TB02
SENSOR TYPE	R0	x				
	MA		x	x	x	x
	MB		x	x	x	x

1.2 - Spool types for DS3M and DS5M

Type S*:
2 solenoids - 3 positions
with spring centering

Sensor RO

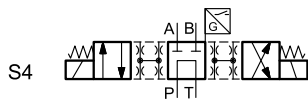
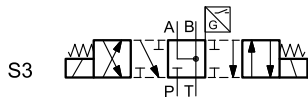
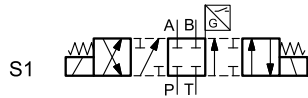

Type SA*:
1 solenoid side A
2 positions (central + external) with spring centering

Sensor MA

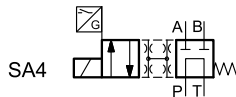
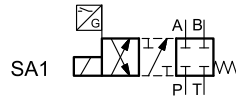

Sensor MB

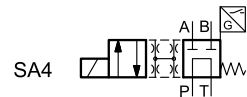
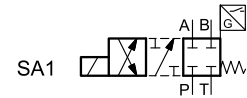

Type SB*:
1 solenoid side B
2 positions (central + external) with spring centering

Sensor MA

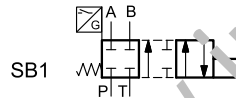

Sensor MB

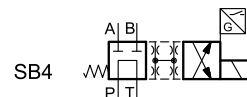
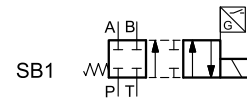

Type TA:
1 solenoid side A
2 external positions with return spring

Sensor MA

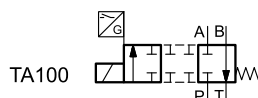
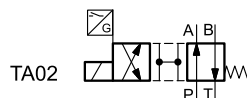
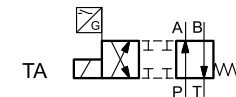

Sensor MB

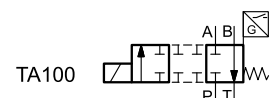
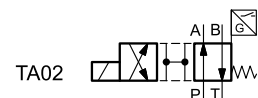
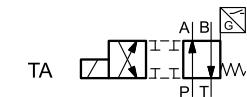

Type TB:
1 solenoid side B
2 external positions with return spring

Sensor MA

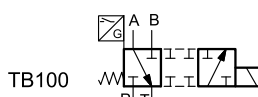
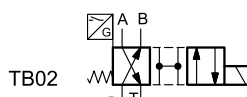
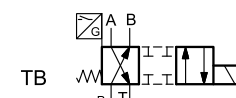

Sensor MB

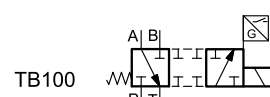
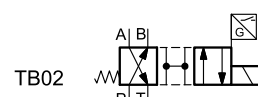
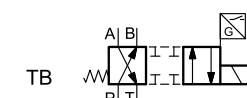



2 - CHARACTERISTIC CURVES OF DIRECT OPERATED SOLENOID VALVES

(obtained with viscosity 36 cSt at 50 °C)

2.1 - DS3M - Pressure drops Δp -Q

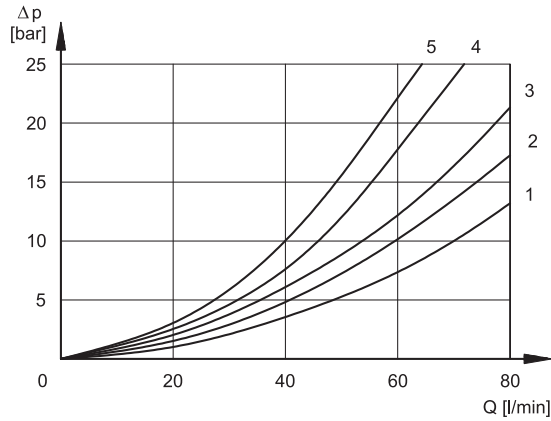

SPOOL TYPE	FLOW DIRECTION				
	P→A	P→B	A→T	B→T	P→T
	CURVES ON GRAPH				
S1, SA1; SB1	2	2	3	3	-
S3	3	3	1	1	-
S4, SA4	5	5	5	5	3
TA, TB	2	2	2	2	-
TA100, TB100	4	4	4	4	-

For S3 in central position B→T refer to curve 3.

2.2 - DS5M - Pressure drops Δp -Q

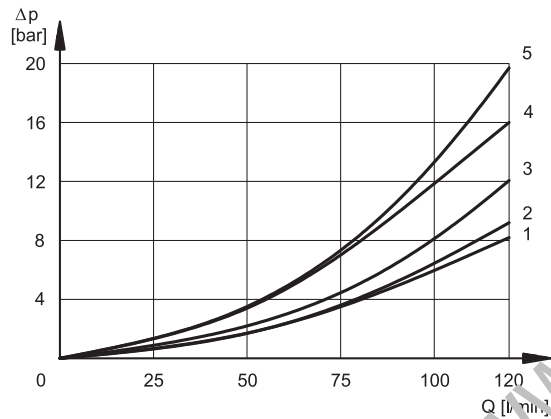

SPOOL TYPE	FLOW DIRECTION				
	P→A	P→B	A→T	B→T	P→T
	CURVES ON GRAPH				
S1, SA1, SB1	2	2	1	1	-
S3	2	1	2	3	-
S4, SA4, SB4	1	1	2	2	4
TA, TB, TA02, TB02	3	3	2	2	-
TA100, TB100	2	2	2	2	-

For S3 in central position B→T refer to curve 5.

2.3 - Performance limits for DS3M and DS5M solenoid valves

The curves define the flow rate operating fields according to the valve pressure of the different versions.

The values have been obtained according to ISO 6403 norm with solenoids at rated temperature and supplied with voltage equal to 90% of the nominal voltage. The values have been obtained with mineral oil, viscosity 36 cSt, temperature 50 °C and filtration according to ISO 4406:1999 class 18/16/13.

The operating limits can be considerably reduced if a 4-way valve is used as 3-way valve with port A or B plugged or without flow.

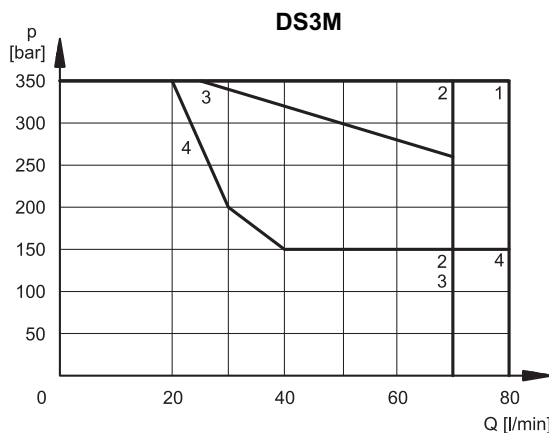

SPOOL	CURVE	
	P→A	P→B
S1,SA1	1	1
S3,	4	4
S4, SA4	2	2
TA, TB	1	1
TA100, TB100	3	3

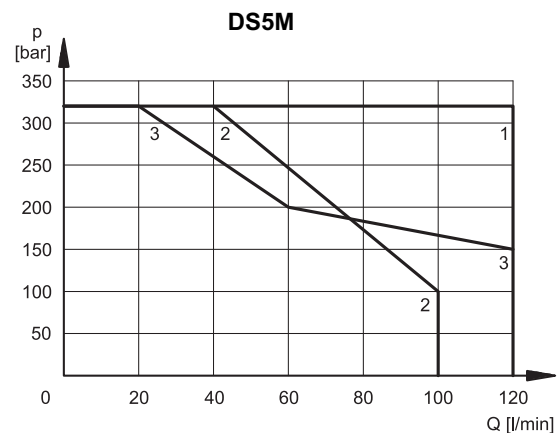

SPOOL	CURVE	
	P→A	P→B
S1	1	1
S3	3	3
S4	2	2
TA02	1	1
TA, TA100	1	1

2.4 - Switching times

The indicated values had obtained according to ISO 6403 standards, using mineral oil with viscosity 36 cSt at 50 °C.

TIMES [ms]	ENERGIZING	DE-ENERGIZING
DS3M	25 ÷ 75	15 ÷ 25

TIMES [ms]	ENERGIZING	DE-ENERGIZING
DS5M	100 ÷ 150	20 ÷ 50

3 - OVERALL AND MOUNTING DIMENSIONS FOR DIRECT OPERATED VALVES

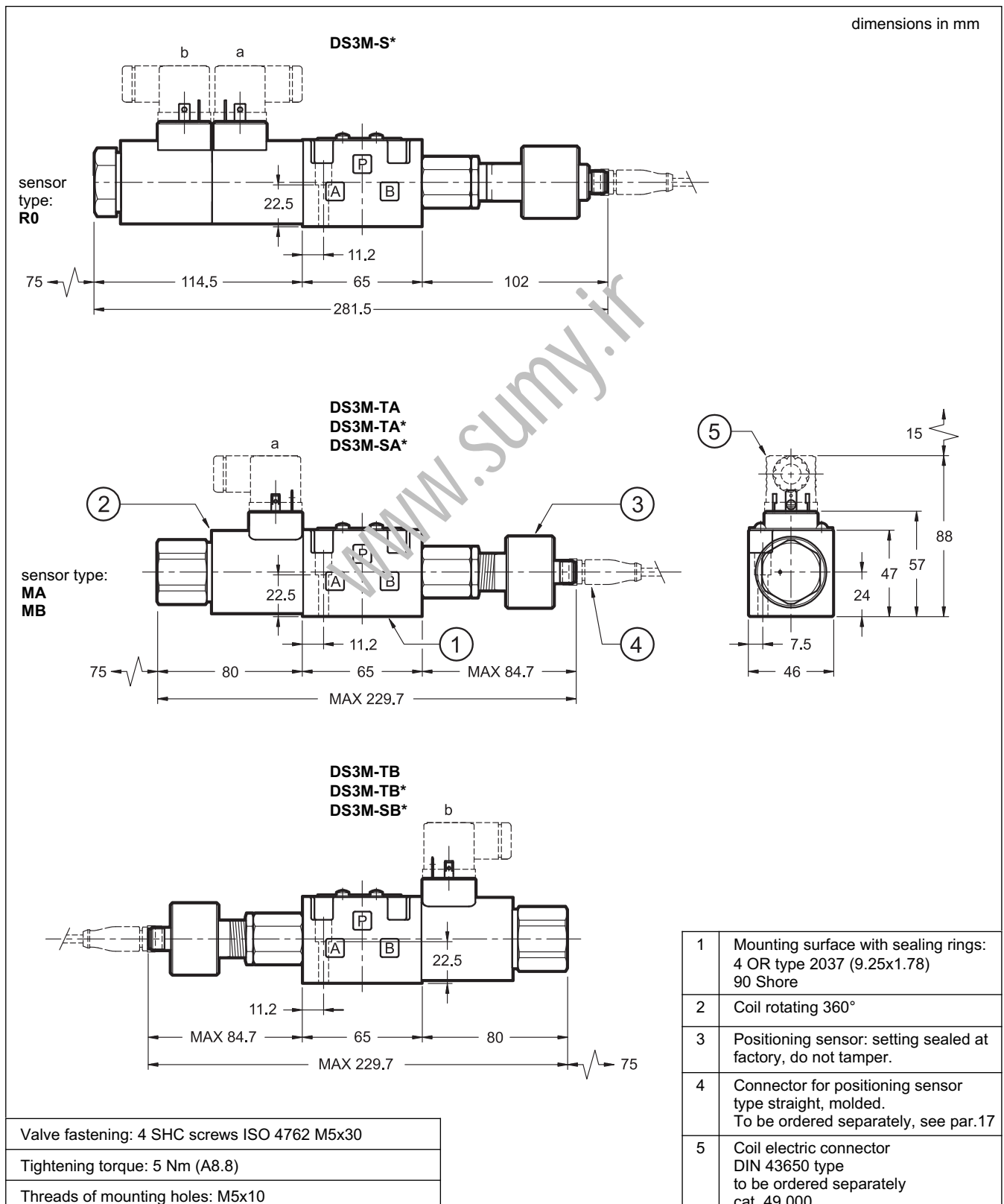

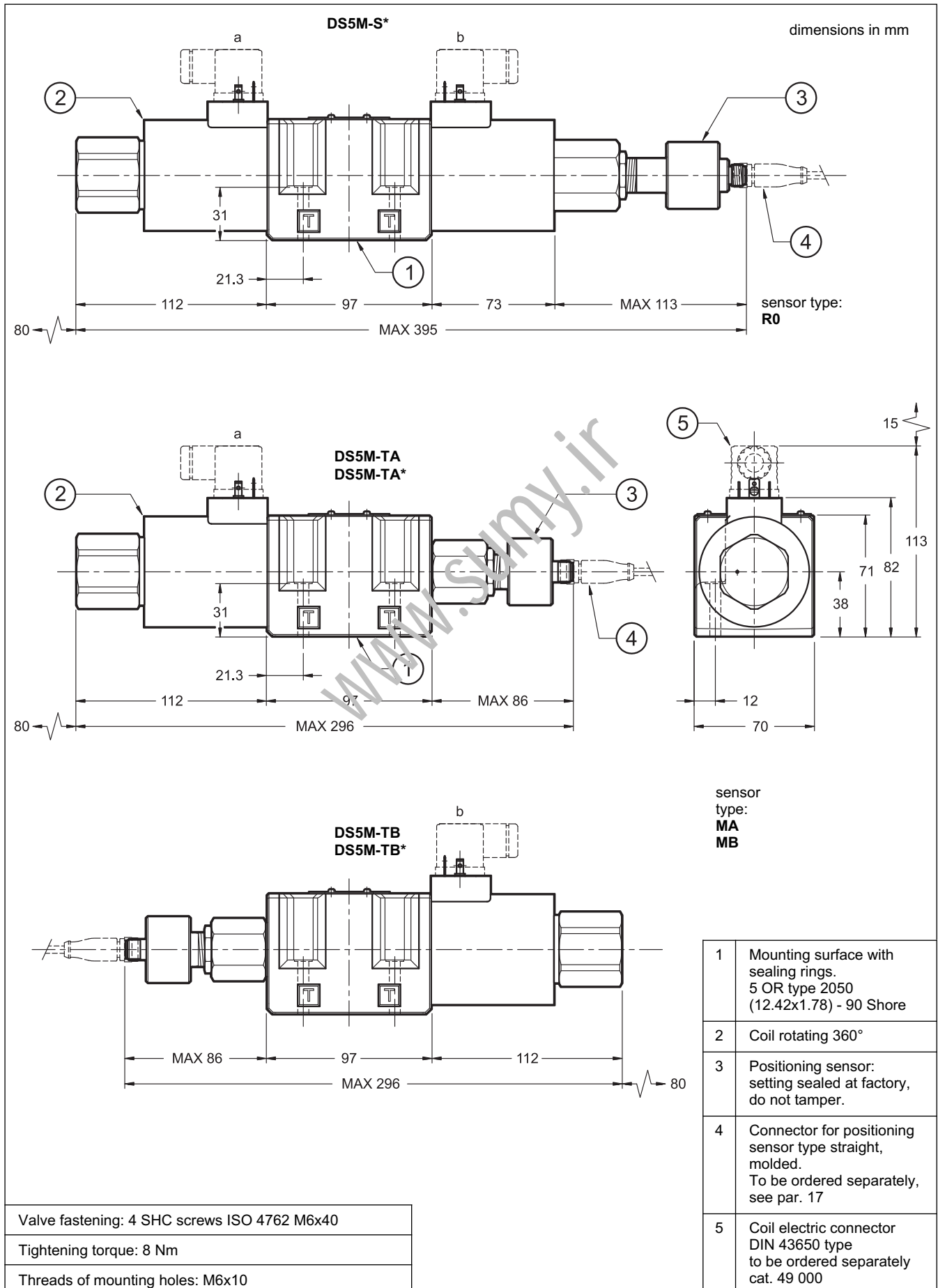

4 - IDENTIFICATION OF PILOT OPERATED SOLENOID VALVES

4.1 - Identification code

D	S	P	M	-	/	-	/	/	/	K1	/
----------	----------	----------	----------	----------	----------	----------	----------	----------	----------	-----------	----------

Directional valve,
Solenoid controlled
Pilot operated

Size: _____
5 = CETOP P05
5R = ISO 4401-05 (CETOP R05)
7 = ISO 4401-07 (CETOP 07)
8 = ISO 4401-08 (CETOP 08)
10 = ISO 4401-10 (CETOP 10)

Monitoring of the spool position _____

Spool type (see paragraph 4.2) _____
S1 SA1 SB1 TA TB
S3 TA100 TB100
S4
RK

Series: _____
10 = for DSP5M, DSP5RM and DSP8M
20 = for DSP7M
30 = for DSP10M
 (the overall and mounting dimensions within the same ten remain unchanged)

Seals: _____
N = NBR seals for mineral oil (**standard**)
V = FPM seals for special fluids

Piloting (see paragraph 6): _____
I = internal (not available for S4 spool)
E = external
C = internal piloting with backpressure valve
 (available on DSP7 and DSP8 only)
Z = internal piloting with 30 bar fixed adjustment pressure reducing valve
 (see par. 5.5)

Monitored position:
(see par. 16 for switching logic)
1 positioning sensor
R0 = rest position monitored
MA = position 'a' monitored
MB = position 'b' monitored
2 positioning sensor
M0 = rest position monitored
MAB = 'a' and 'b' positions monitored

Coil electrical connection:
plug for connector type
DIN 43650 (**standard**)

DC power supply
D12 = 12 V **D110** = 110 V
D24 = 24 V **D220** = 220 V

P = Subplate with restrictor on port P placed under the pilot valve
 (omit for valves with piloting type Z and for valves with option D - control of the shifting speed of the main spool)
D = shifting speed of the main spool (see par. 7)

Drainage (see paragraph 6):
I = Internal
E = External

Verify spool and sensor type availability in the table below

		SPOOLS				
		S*	SA* SB*	TA TB	TA100 TB100	RK
SENSOR TYPE	R0	x				
	MA		x	x	x	x
	MB		x	x	x	x
	M0	x				
	MAB	x	x	x	x	

NOTE: DSP10M available with spools S1 or S4, with monitored position R0 or M0 only.

NOTE: To be compliant with the EN 693:2011 standard, the valves have no manual override.

4.2 - Spool types for DSP5M, DSP5RM, DSP7M and DSP8M

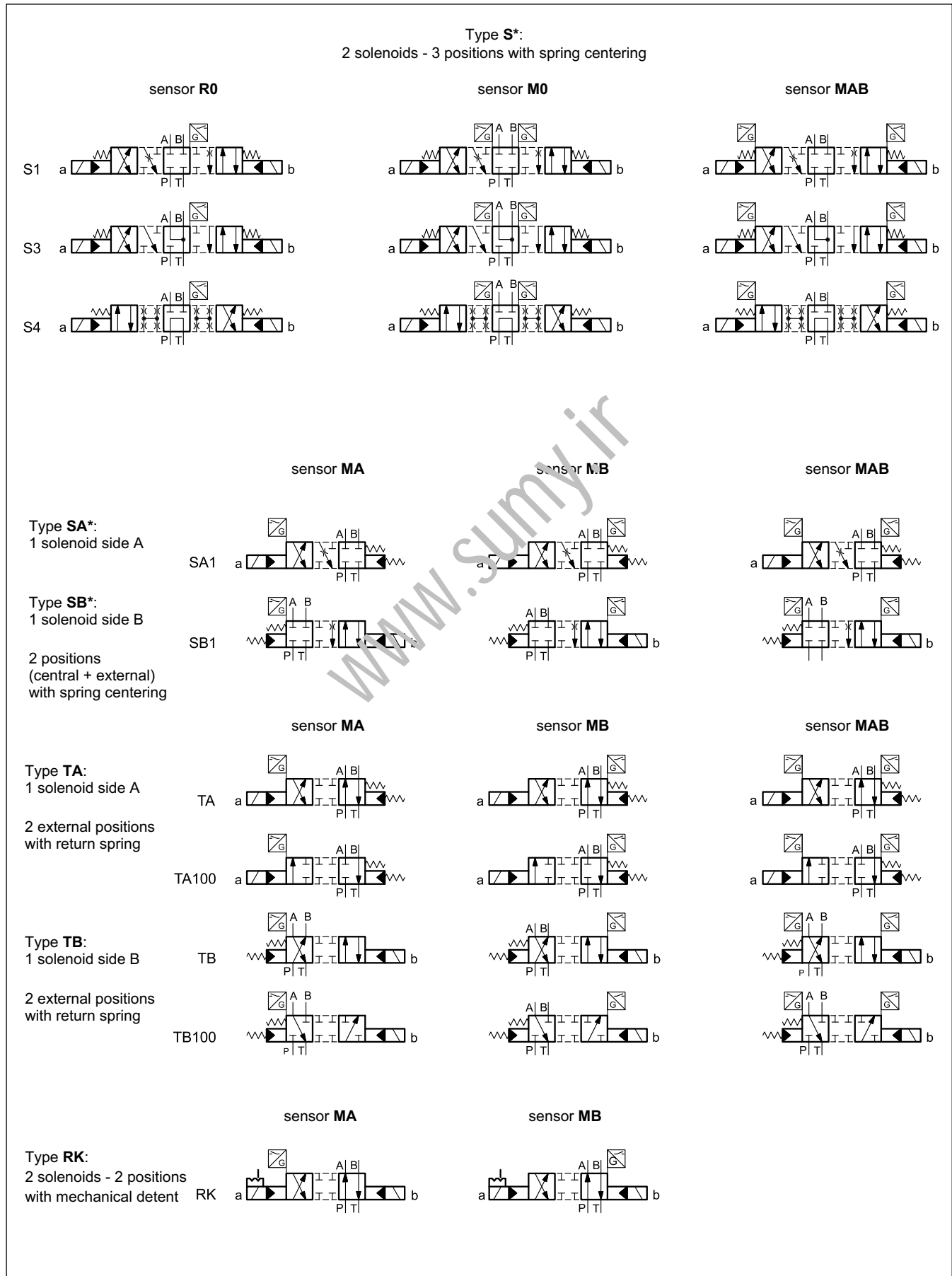

5 - CHARACTERISTIC CURVES AND PERFORMANCES

(values obtained with viscosity 36 cSt at 50 °C)

5.1 - DSP5M and DSP5RM - Pressure drops Δp -Q

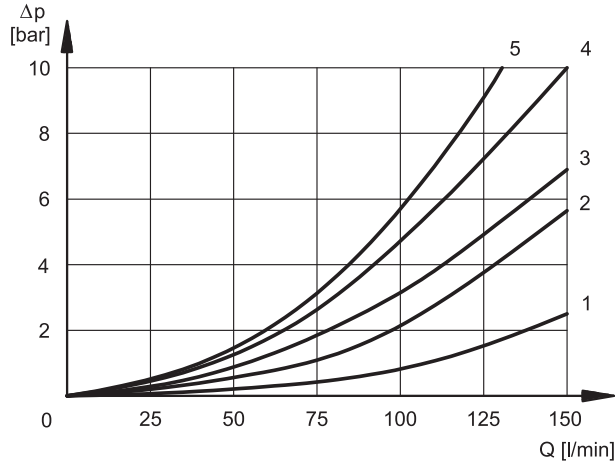

SPOOL TYPE	FLOW DIRECTION				
	P→A	P→B	A→T	B→T	P→T
	CURVES ON GRAPH				
S1, SA1	4	4	1	1	-
S3	4	4	1	1	-
S4	5	5	2	3	5
TA, TB	4	4	1	1	-
TA100, TB100	3	3	1	1	-
RK	4	4	1	1	-

For pressure drops of the S3 spool in central position refer to the curve 4.

5.2 - DSP7M - Pressure drops Δp -Q

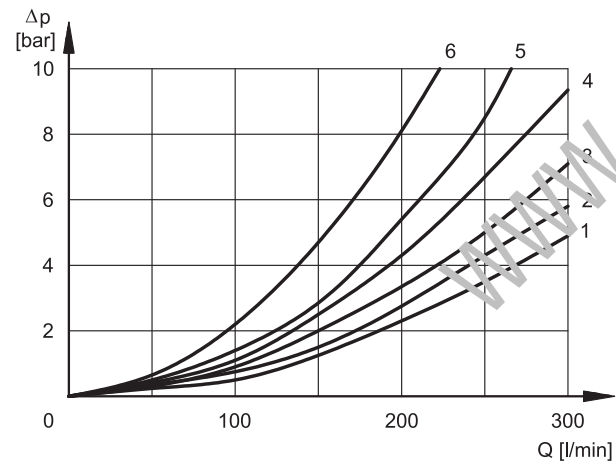

SPOOL TYPE	FLOW DIRECTION				
	P→A	P→B	A→T	B→T	P→T
	CURVES ON GRAPH				
S1, SA1	1	1	4	5	-
S3	1	1	5	5	-
S4	2	2	5	6	5
TA, TB	1	1	4	5	-
TA100, TB100	3	3	3	5	-
RK	1	1	4	5	-

For pressure drops of the S3 spool in central position refer to the curve 5.

5.3 - DSP8M - Pressure drops Δp -Q

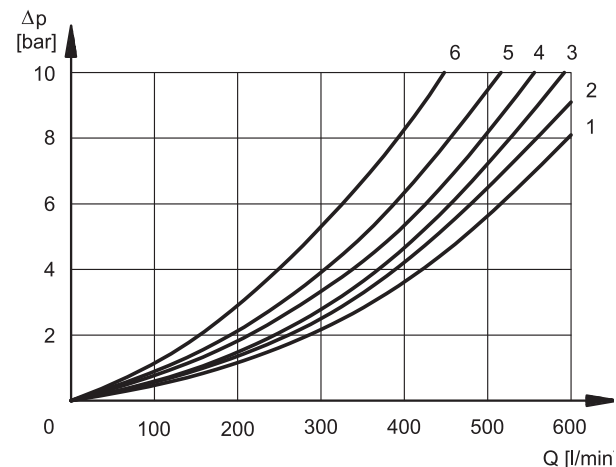

SPOOL TYPE	FLOW DIRECTION				
	P→A	P→B	A→T	B→T	P→T
	CURVES ON GRAPH				
S1, SA1	2	2	3	3	-
S3	2	2	2	1	-
S4	4	4	3	5	6
TA, TB	2	2	3	3	-
TA100, TB100	5	5	5	5	-
RK	2	2	3	3	-

For pressure drops of the S3 spool in central position refer to the curve 4.



5.4 - DSP10M - Pressure drops Δp -Q

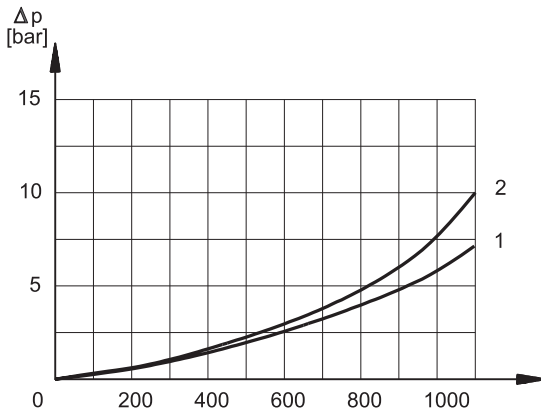

SPOOL TYPE	FLOW DIRECTION				
	P→A	P→B	A→T	B→T	P→T
	CURVES ON GRAPH				
S1	1	1	1	1	-
S4	2	2	2	2	-

5.5 - Performance limits for pilot operated valves

PRESSURES	DSP5M DSP5RM	DSP7M	DSP8M	DSP10M
Max pressure in P, A, B ports	320	350	350	350
Max pressure in T line	210	210	210	210
Max pressure in Y line	210	210	210	210
Min piloting pressure NOTE 1	5 ÷ 10	5 ÷ 12	7 ÷ 14	6 ÷ 12
Max piloting pressure NOTE 2	210	210	210	280

NOTE 1: minimum piloting pressure can be the lower range value at low flow rates, but with higher flow rates the higher value is needed.

NOTE 2: if the valve operates with higher pressure it is necessary to use the version with external pilot and reduced pressure. Otherwise, the valve with internal pilot and pressure reducing valve with 30 bar fixed adjustment can be ordered.

Add the letter **Z** to the identification code to order this option (see par. 4.1).

MAXIMUM FLOW RATES		DSP5M DSP5RM		DSP7M		DSP8M		DSP10M	
Spool type	[l/min]	PRESSURES							
		210 bar	320 bar	210 bar	350 bar	210 bar	350 bar	210 bar	350 bar
S4 - TA100		120	100	200	150	500	450	750	600
S1 - S3 - TA - RK		150	120	300	300	600	500	900	700

5.6 - Switching times

The values indicated refer to a solenoid valve working with piloting pressure of 100 bar, with mineral oil at a temperature of 50°C, at viscosity of 36 cSt and with PA and BT connections.

The energizing and de-energizing times are obtained at the pressure variation which occurs on the lines.

TIMES ($\pm 10\%$) [ms]	ENERGIZING		DE-ENERGIZING	
	2 Pos.	3 Pos.	2 Pos.	3 Pos.
DSP5M - DSP5RM	60	50	50	40
DSP7M	75	60	60	45
DSP8M	100	70	80	50
DSP10M	-	100	-	140

6 - PILOTING AND DRAINAGE

These valves are available with piloting and drainage, both internal and external. The version with external drainage allows for a higher back pressure on the outlet.

TYPE OF VALVE		Plug assembly	
		X	Y
IE	internal pilot and external drain	NO	YES
II	Internal pilot and internal drain	NO	NO
EE	external pilot and external drain	YES	YES
EI	external pilot and internal drain	YES	NO

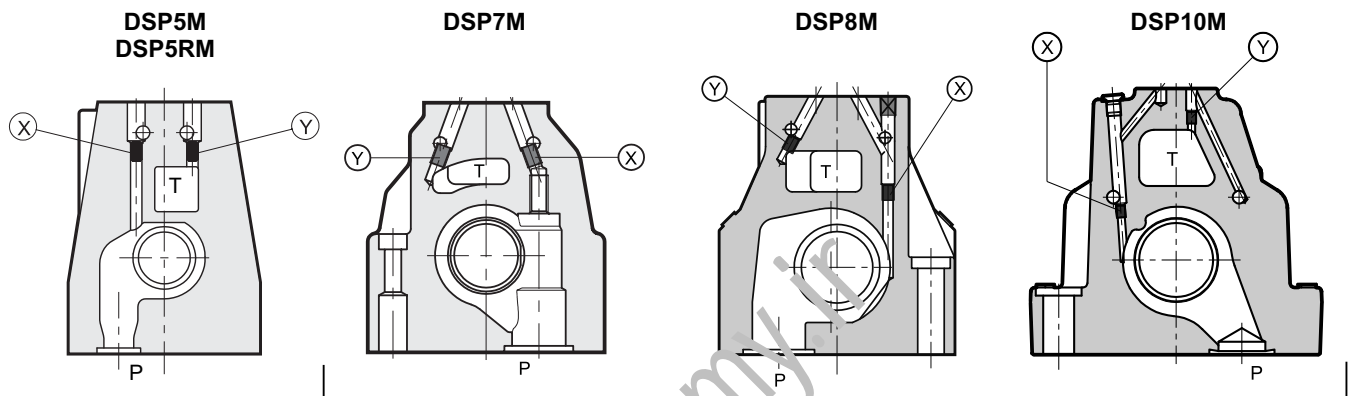

X: plug M5x6 for external pilot
Y: plug M5x6 for external drain

X: plug M6x8 for external pilot
Y: plug M6x8 for external drain

6.1 - Backpressure valve incorporated on line P (C option)

DSP7M and DSP8M valves are available upon request with backpressure valve incorporated on line P. This is necessary to obtain the piloting pressure when the control valve, in rest position, has the line P connected to the T port (spools S4).

The cracking pressure is of 5 bar with a minimum flow rate of 15 l/min.

In the C version the piloting is always internal.

NOTE: the backpressure valve can't be used as check valve because it doesn't assure the seal.

Add **C** to the identification code for this request (see paragraph 4.1).

For DSP7M only, the backpressure valve can be also delivered separately and it can be easily mounted on line P of the main control valve. Ask for code **0266577** to order the backpressure valve.

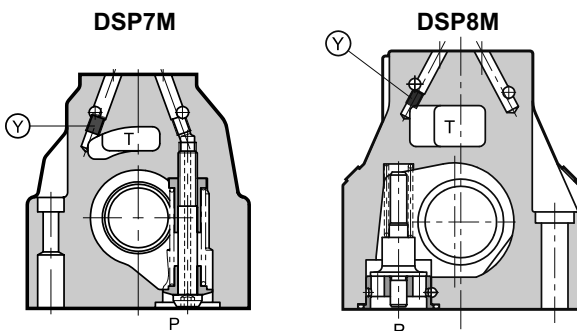
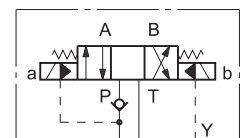

pilot always internal
Y: plug M6x8 for external drain

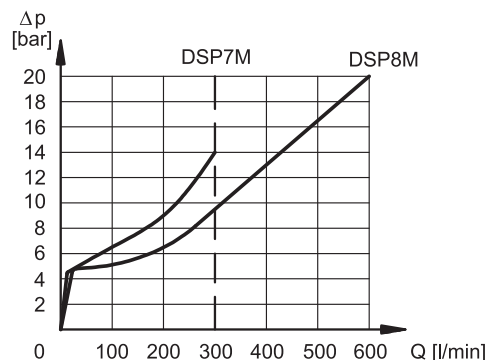

The curve refers to the pressure drop (body part only) with backpressure valve inside, to which the pressure drop of the reference spool must be added. (see par. 5)

7 - OPTIONS

7.1 - Option D : control of the main spool shifting speed

By placing a MERS type double flow control valve between the pilot solenoid valve and the hydropiloted valve, the piloted flow rate can be controlled and therefore the change over smoothness can be varied.

Add the letter **D** to the identification code to request this device (see paragraph 4.1).

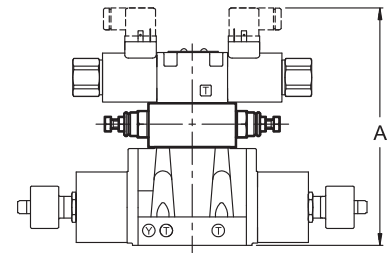

dimensions in mm

	DSP5	DSP7	DSP8	DSP10
A	218	225	254	307

8 - ELECTRICAL FEATURES

8.1 - Solenoids

These are essentially made up of two parts: tube and coil. The tube is threaded into the valve body and includes the armature that moves immersed in oil, without wear. The inner part, in contact with the oil in the return line, ensures heat dissipation.

The coil is fastened to the tube by a threaded ring, and can be rotated and locked to suit the available space.

NOTE 1 : In order to further reduce the emissions, use of type H connectors is recommended. These prevent voltage peaks on opening of the coil supply electrical circuit (see catalogue 49 000).

NOTE 2: The IP65 protection degree is guaranteed only with the connector correctly connected and installed.

8.2 - Current and absorbed power

The tables shows current and power consumption values relevant to the different coil types for DC.

DS3M, DSP5M, DSP5RM, DSP7M, DSP8M and DSP10M (values ± 10%)

Suffix	Nominal voltage [V]	Resistance at 20°C [Ω]	Current consumpt. [A]	Power consumpt. [W]	Coil code
D12	12	4,4	2,72	32,7	1903080
D24	24	18,6	1,29	31	1903081
D110	110	436	0,26	28,2	1903464
D220	220	1758	0,13	28,2	1903465

VOLTAGE SUPPLY FLUCTUATION	± 10% Vnom
MAX SWITCH ON FREQUENCY	
DS3M	15.000 ins/hr
DS5M	13.000 ins/hr
DSP5M - DSP5RM	5.000 ins/hr
DSP7M	5.000 ins/hr
DSP8M	4.000 ins/hr
DSP10M	3.000 ins/hr
DUTY CYCLE	100%
ELECTROMAGNETIC COMPATIBILITY (EMC) (NOTE 1)	In compliance with 2004/108/EC
LOW VOLTAGE	In compliance with 2006/95/EC
CLASS OF PROTECTION: Atmospheric agents (EN 60529) Coil insulation (VDE 0580) Impregnation	IP 65 (NOTE 2) class H class F

DS5M (values ± 5%)

Suffix	Nominal voltage [V]	Resistance at 20°C [Ω]	Current consumpt. [A]	Power consumpt. [W]	Coil code
D12	12	3,2	3,75	45	1903200
D24	24	12	2	48	1903201
D110	110	250	0,44	48	1903204
D220	220	1050	0,21	47	1903205

9 - COIL CONNECTORS

The solenoid operated valves are delivered without the connectors. They can be ordered separately.

For the identification of the connector type to be ordered, please see catalogue 49 000.

10 - DSP5M AND DSP5RM OVERALL AND MOUNTING DIMENSIONS

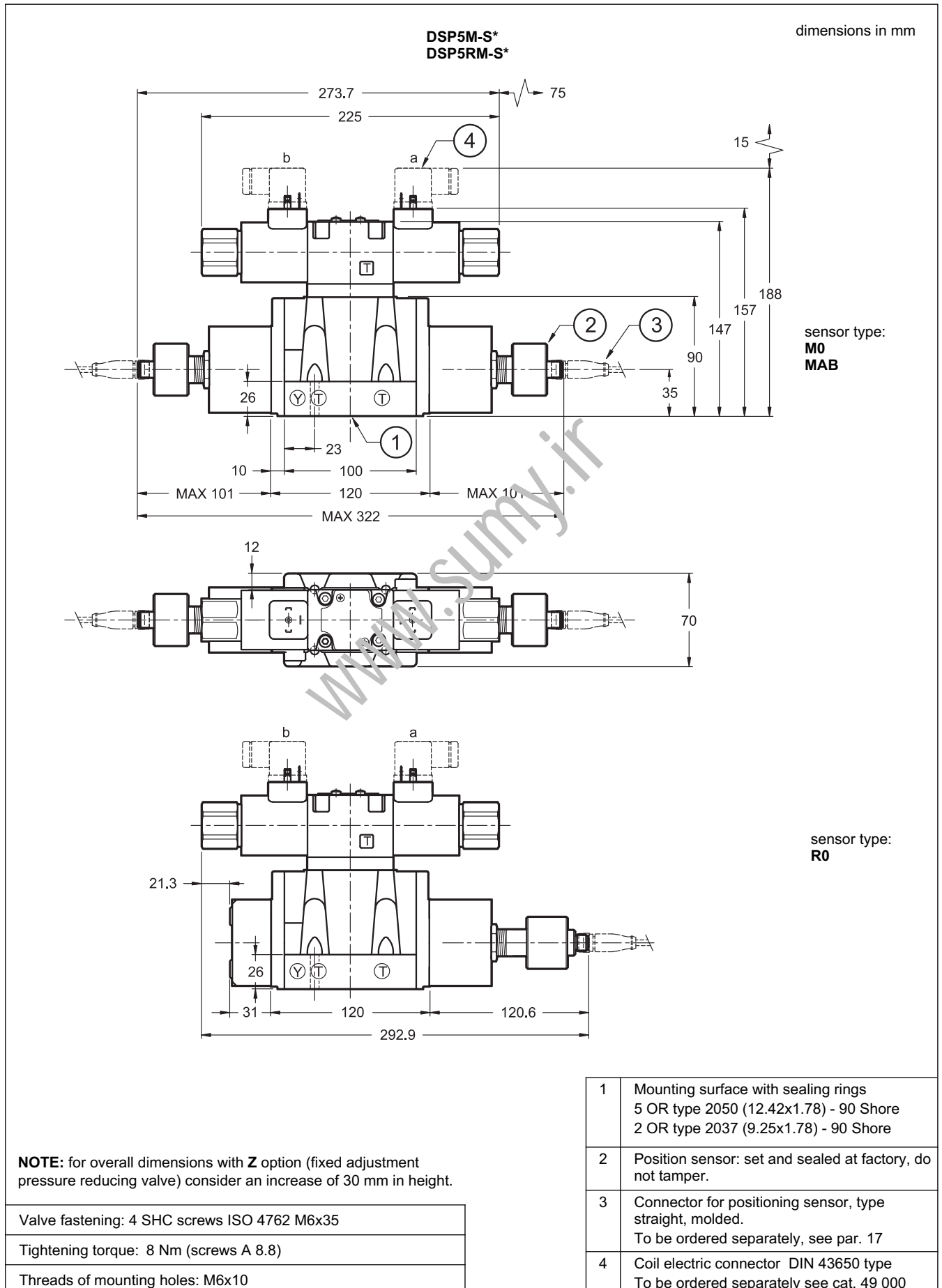

DSP5M-TA, TA100, SA1
 DSP5RM-TA, TA100, SA1

dimensions in mm

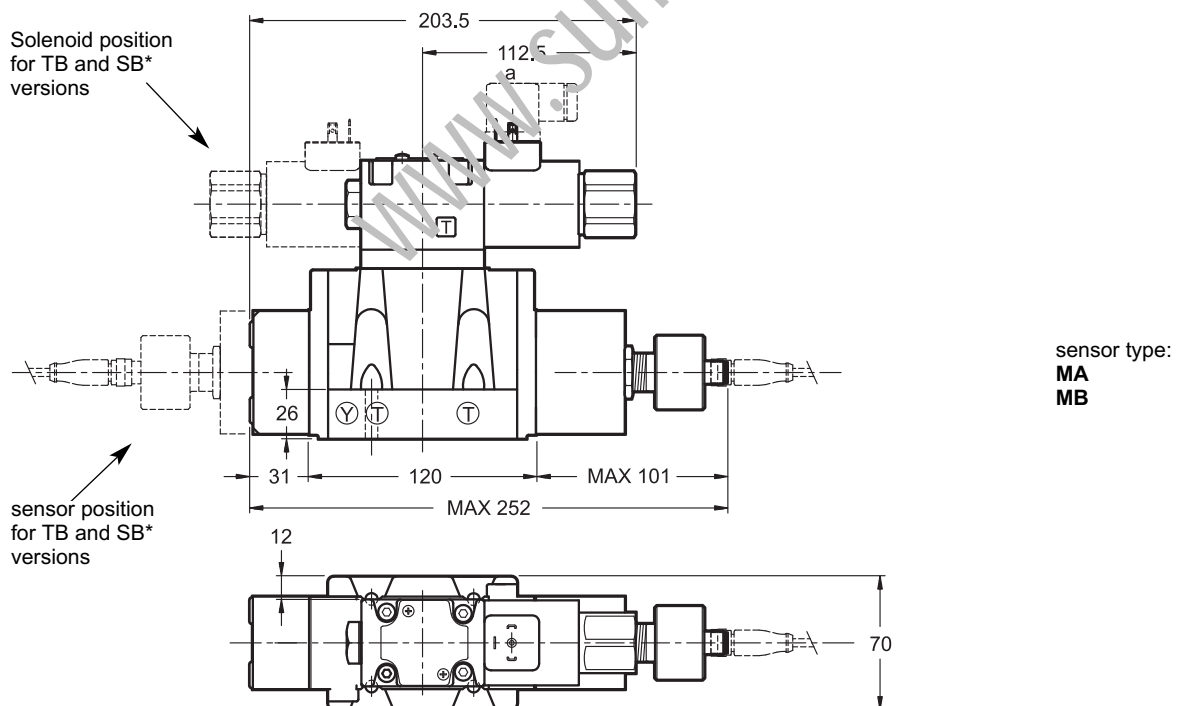
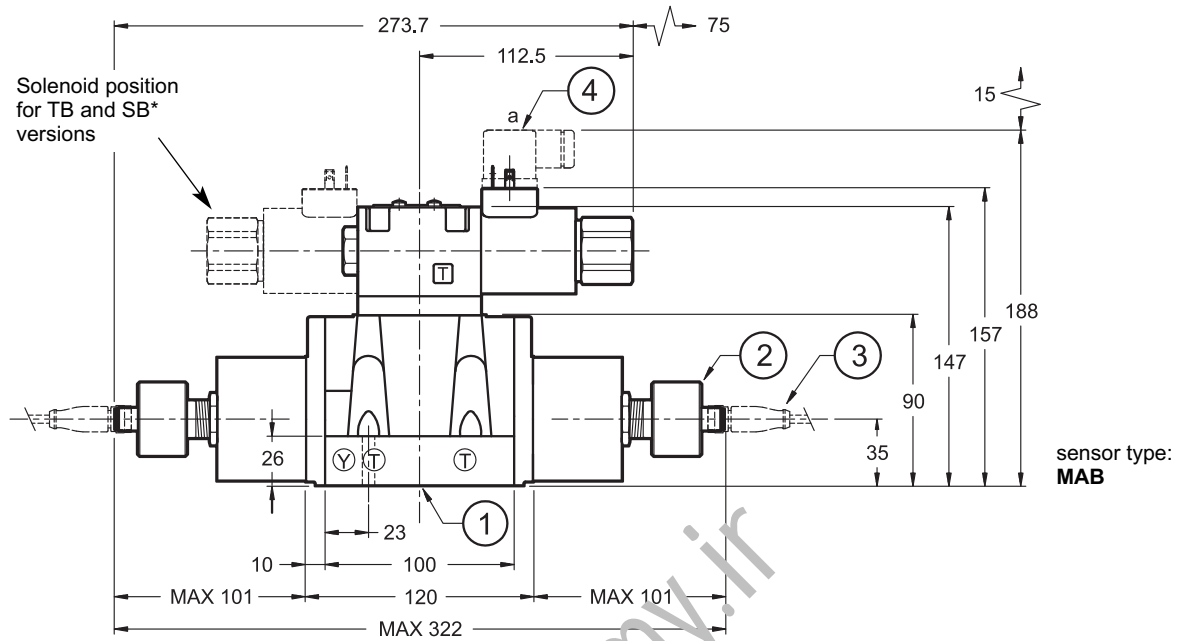

NOTE: for overall dimensions with Z option (fixed adjustment pressure reducing valve) consider an increase of 30 mm in height.

1	Mounting surface with sealing rings 5 OR type 2050 (12.42x1.78) - 90 Shore 2 OR type 2037 (9.25x1.78) - 90 Shore
2	Position sensor: set and sealed at factory, do not tamper.
3	Connector for positioning sensor, type straight, molded. To be ordered separately, see par. 17
4	Coil electric connector DIN 43650 type To be ordered separately see cat. 49 000

dimensions in mm

DSP5M-RK
 DSP5RM-RK

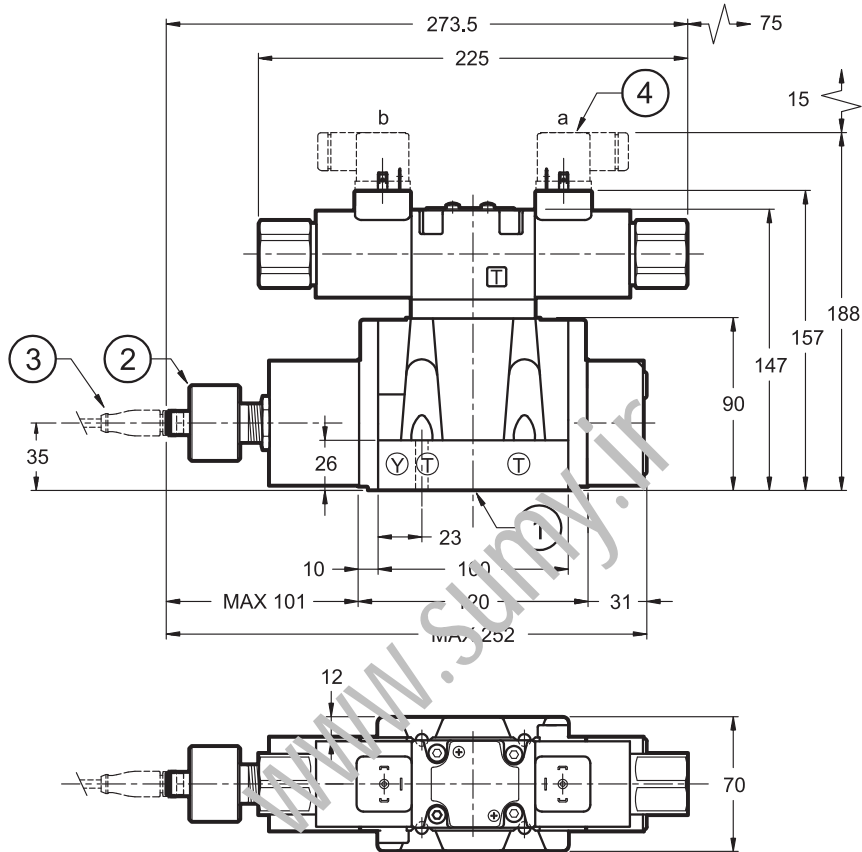

sensor type:
MA
MB

NOTE: for overall dimensions with Z option (fixed adjustment pressure reducing valve) consider an increase of 30 mm in height.

1	Mounting surface with sealing rings 5 OR type 2050 (12.42x1.78) - 90 Shore 2 OR type 2037 (9.25x1.78) - 90 Shore
2	Position sensor: set and sealed at factory, do not tamper.
3	Connector for positioning sensor, type straight, molded. To be ordered separately, see par. 17
4	Coil electric connector DIN 43650 type To be ordered separately see cat. 49 000

11 - DSP7M OVERALL AND MOUNTING DIMENSIONS

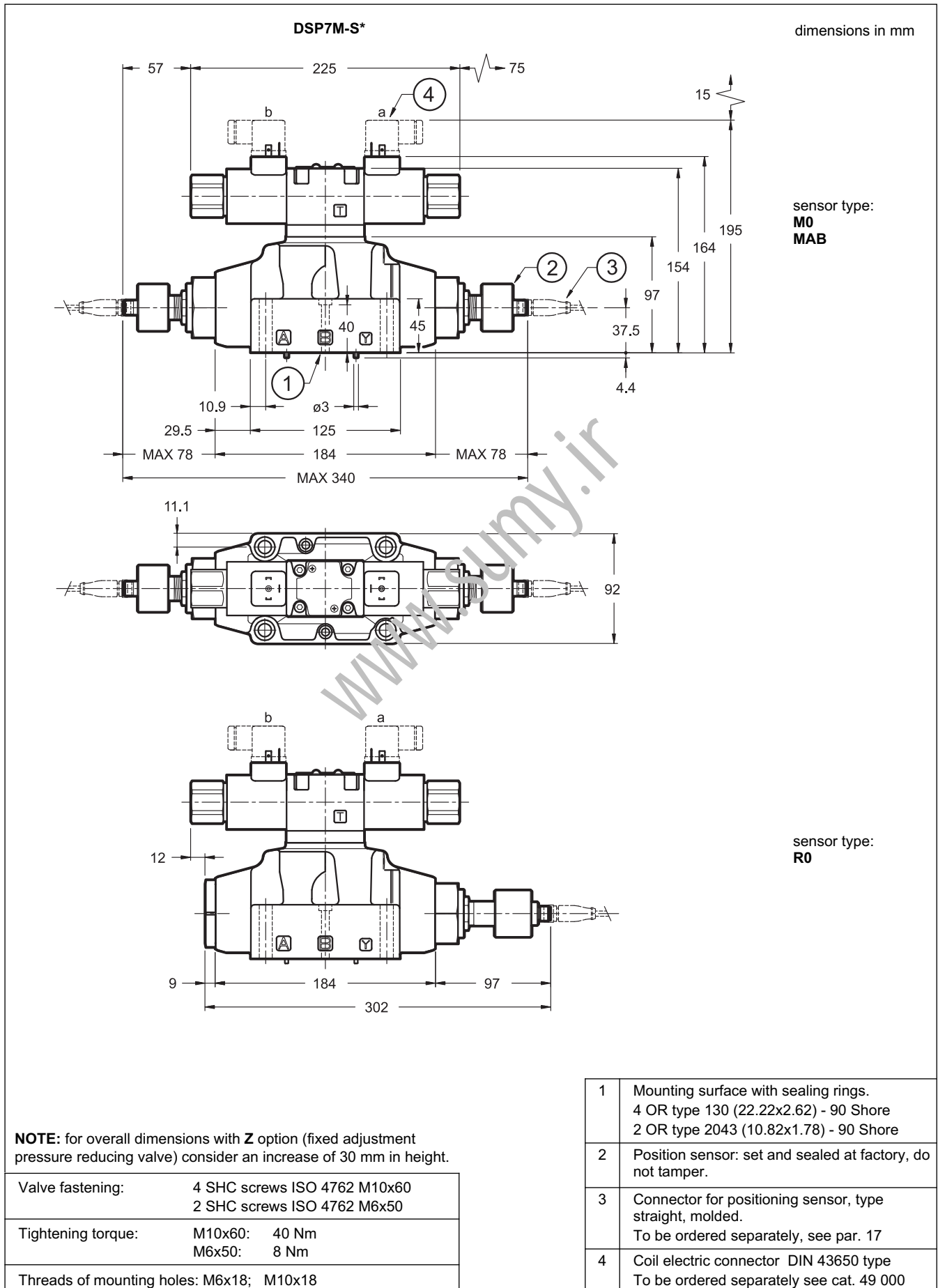

DSP7M-TA, TA100, SA1

dimensions in mm

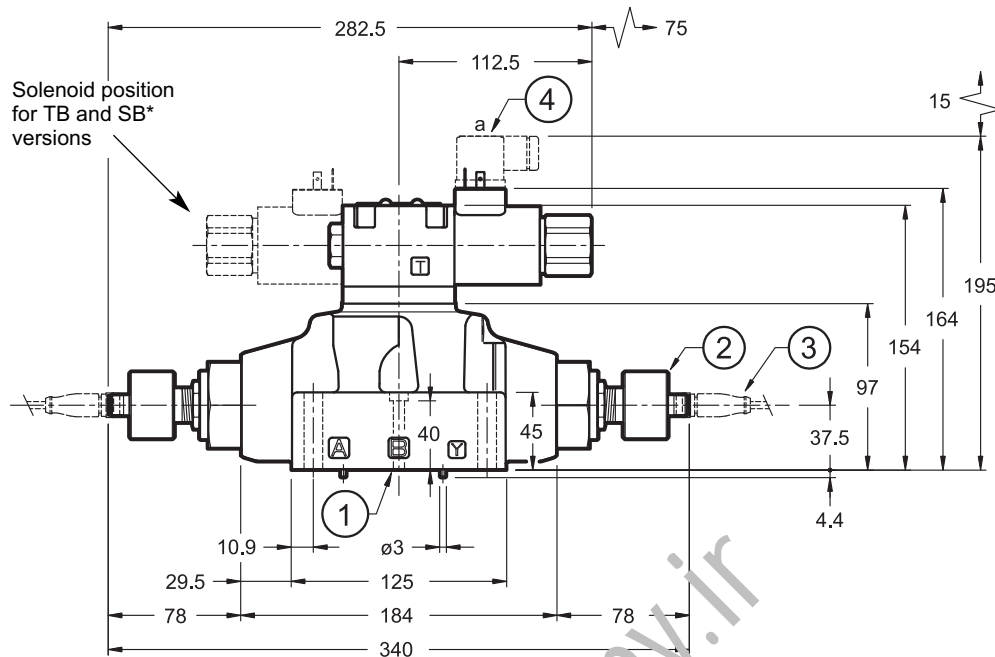

sensor type:
MAB

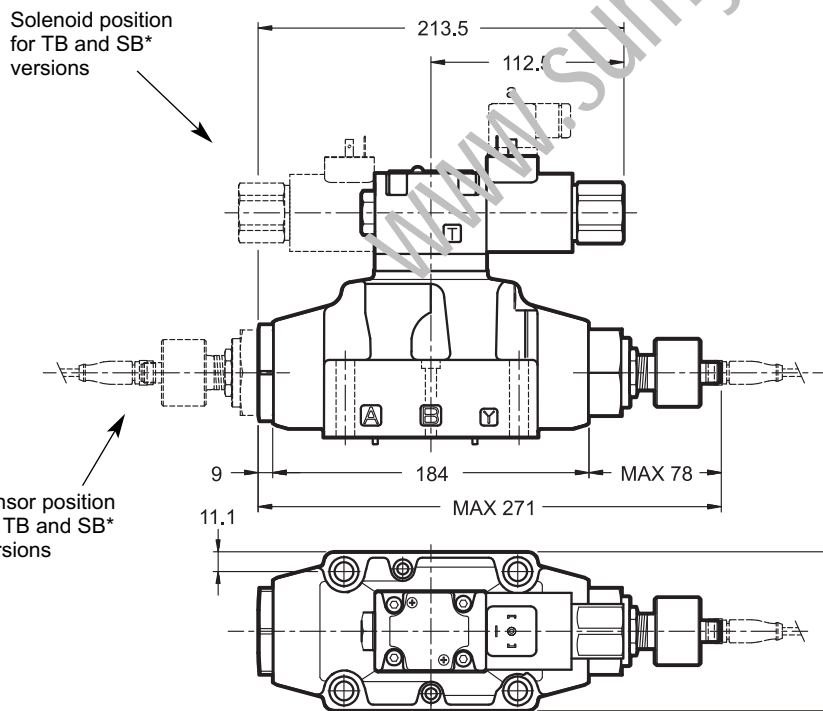

sensor type:
MA
MB

NOTE: for overall dimensions with Z option (fixed adjustment pressure reducing valve) consider an increase of 30 mm in height.

1	Mounting surface with sealing rings. 4 OR type 130 (22.22x2.62) - 90 Shore 2 OR type 2043 (10.82x1.78) - 90 Shore
2	Position sensor: set and sealed at factory, do not tamper.
3	Connector for positioning sensor, type straight, molded. To be ordered separately, see par. 17
4	Coil electric connector DIN 43650 type To be ordered separately see cat. 49 000

dimensions in mm

DSP7M-RK

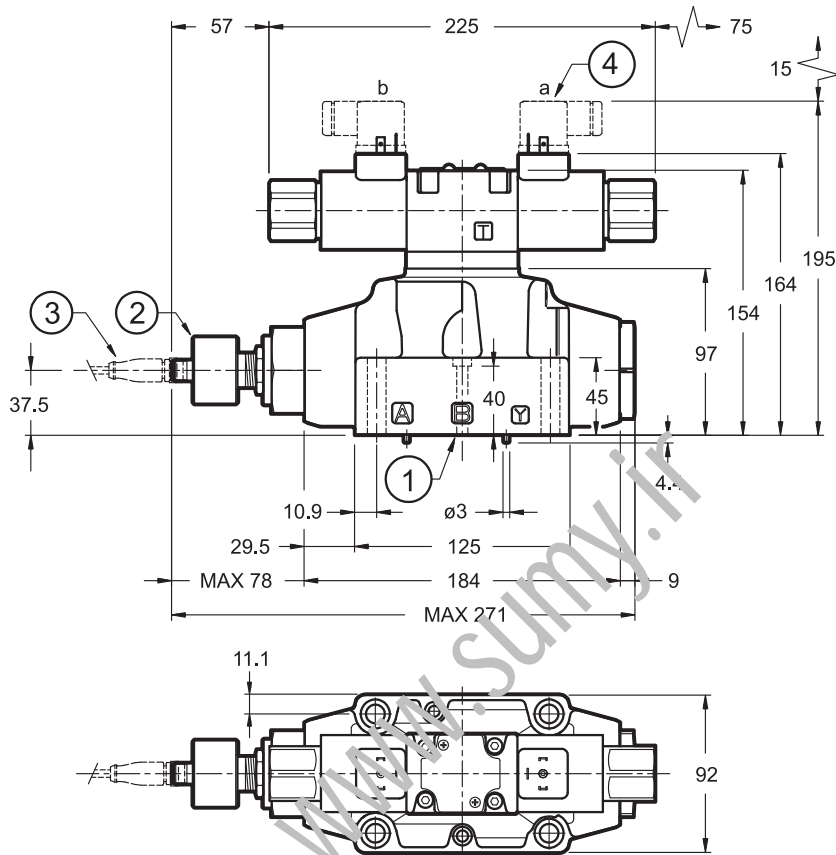

sensor type:
MA
MB

NOTE: for overall dimensions with Z option (fixed adjustment pressure reducing valve) consider an increase of 30 mm in height.

1	Mounting surface with sealing rings. 4 OR type 130 (22.22x2.62) - 90 Shore 2 OR type 2043 (10.82x1.78) - 90 Shore
2	Position sensor: set and sealed at factory, do not tamper.
3	Connector for positioning sensor, type straight, molded. To be ordered separately, see par. 17
4	Coil electric connector DIN 43650 type To be ordered separately see cat. 49 000

12 - DSP8M OVERALL AND MOUNTING DIMENSIONS

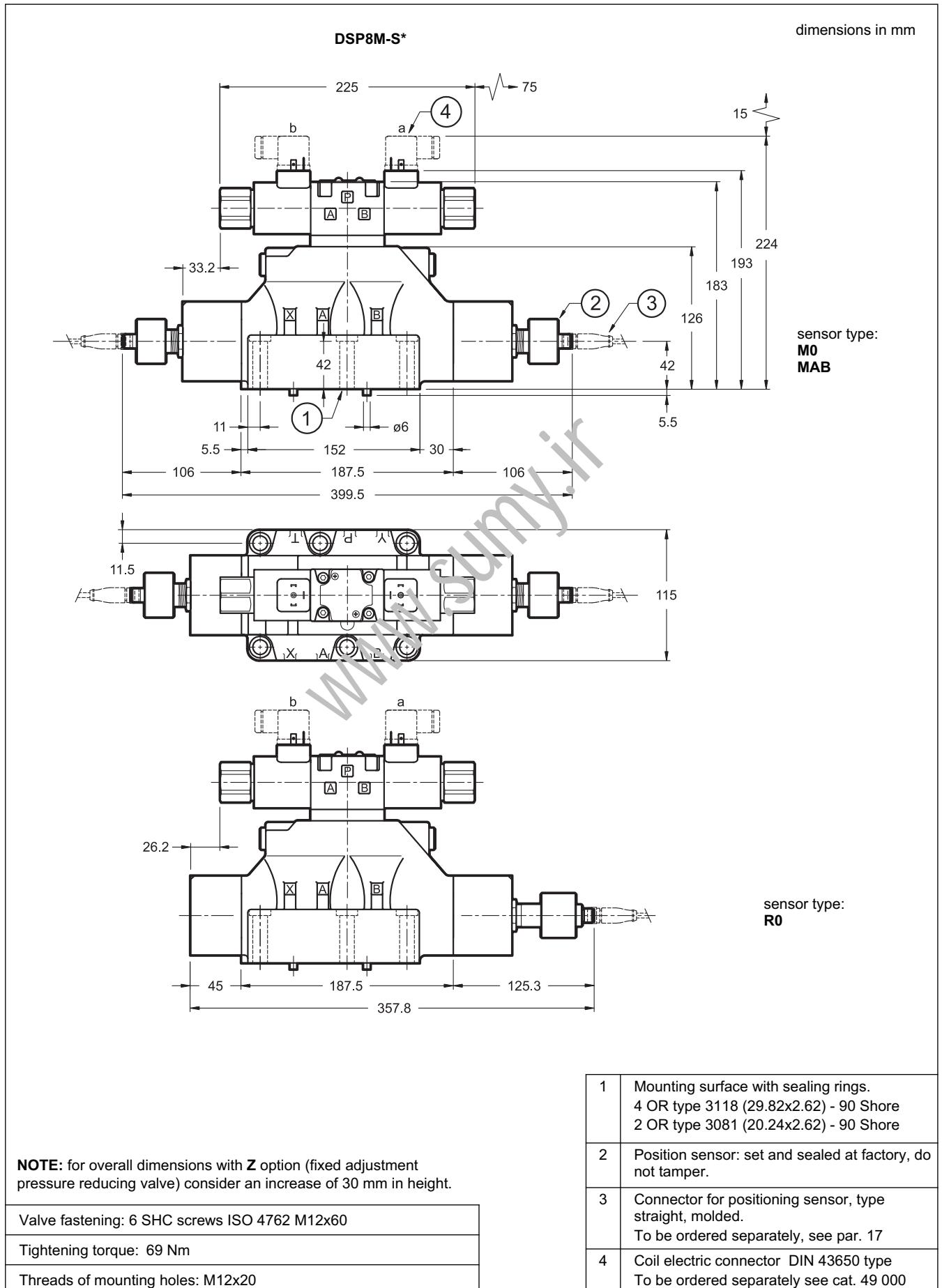

DSP8M-TA, TA100, SA1

dimensions in mm

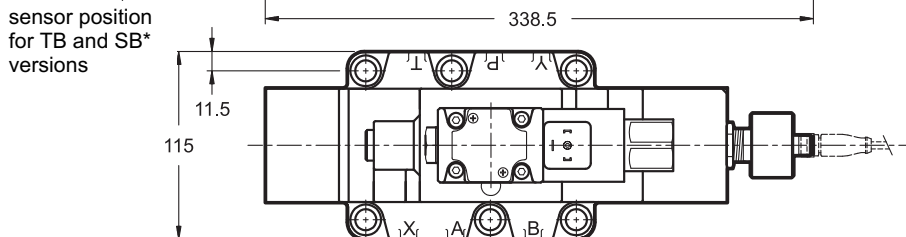
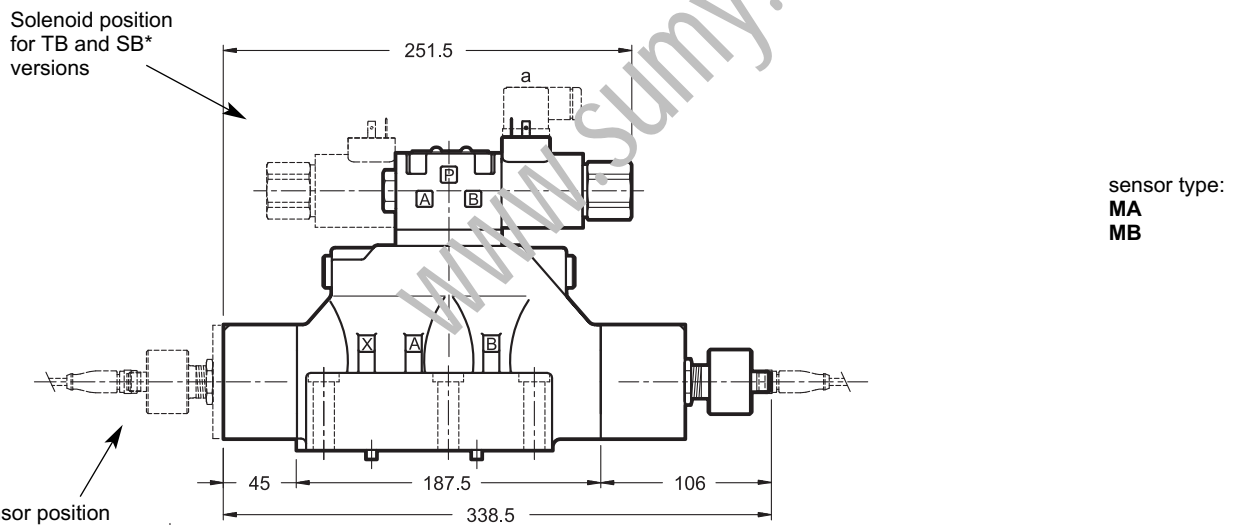
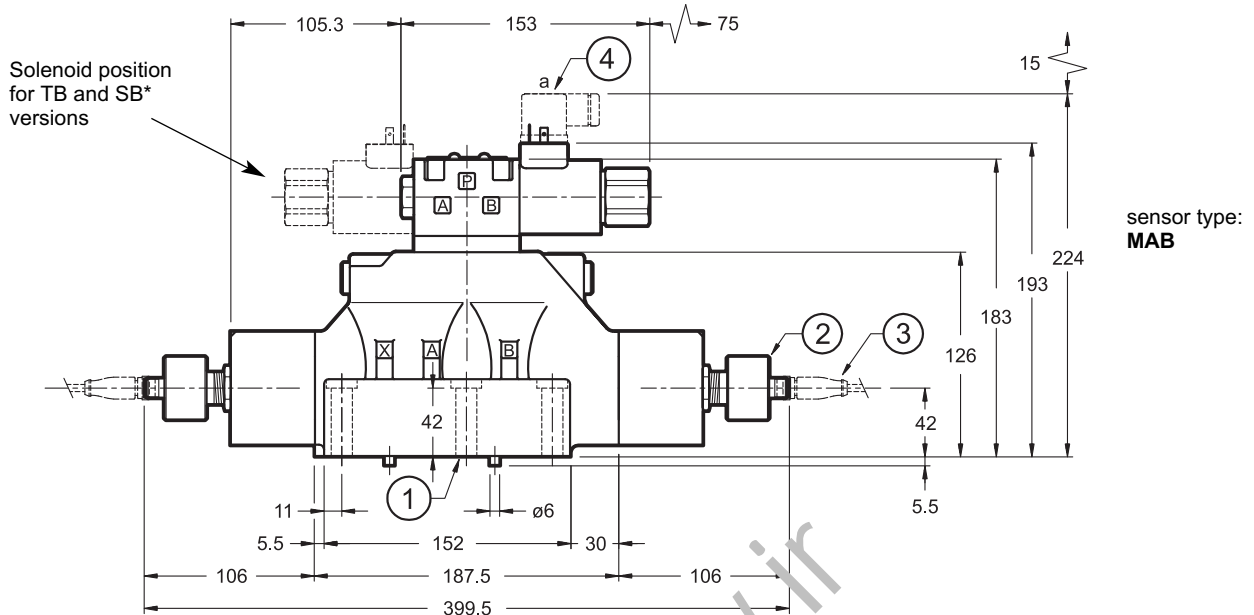

1	Mounting surface with sealing rings. 4 OR type 3118 (29.82x2.62) - 90 Shore 2 OR type 3081 (20.24x2.62) - 90 Shore
2	Position sensor: set and sealed at factory, do not tamper.
3	Connector for positioning sensor, type straight, molded. To be ordered separately, see par. 17
4	Coil electric connector DIN 43650 type To be ordered separately see cat. 49 000

NOTE: for overall dimensions with Z option (fixed adjustment pressure reducing valve) consider an increase of 30 mm in height.

DSP8M-RK

dimensions in mm

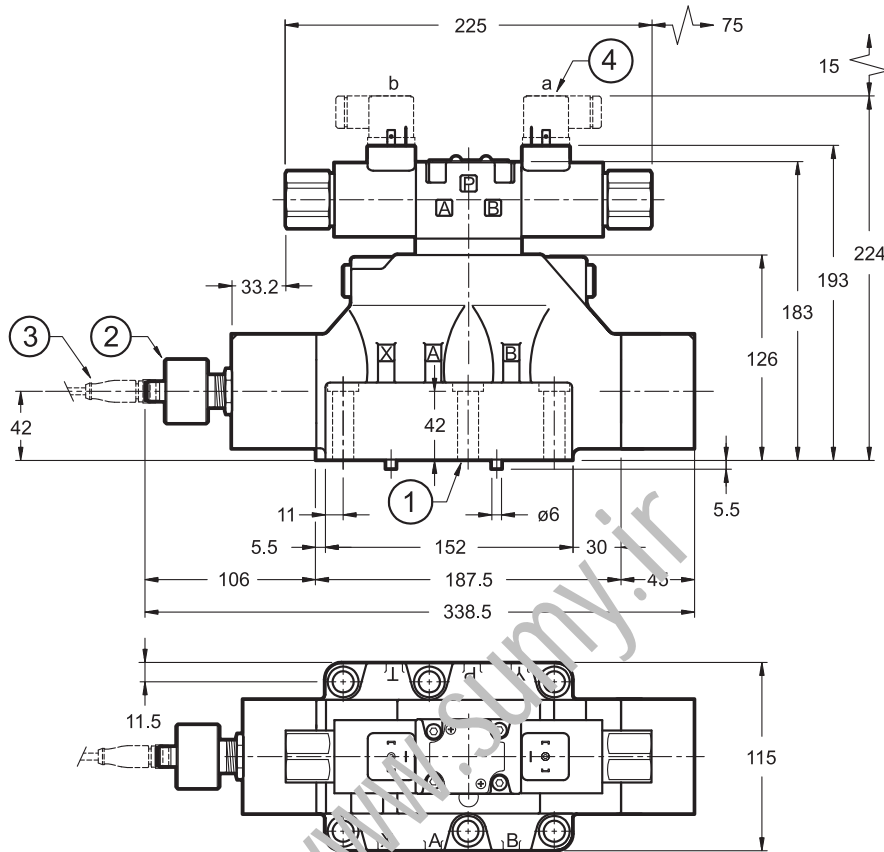

sensor type:
M0
MAB

1	Mounting surface with sealing rings. 4 OR type 3118 (29.82x2.62) - 90 Shore 2 OR type 3081 (20.24x2.62) - 90 Shore
2	Position sensor: set and sealed at factory, do not tamper.
3	Connector for positioning sensor, type straight, molded. To be ordered separately, see par. 17
4	Coil electric connector DIN 43650 type To be ordered separately see cat. 49 000

NOTE: for overall dimensions with Z option (fixed adjustment pressure reducing valve) consider an increase of 30 mm in height.

13 - DSP10M OVERALL AND MOUNTING DIMENSIONS

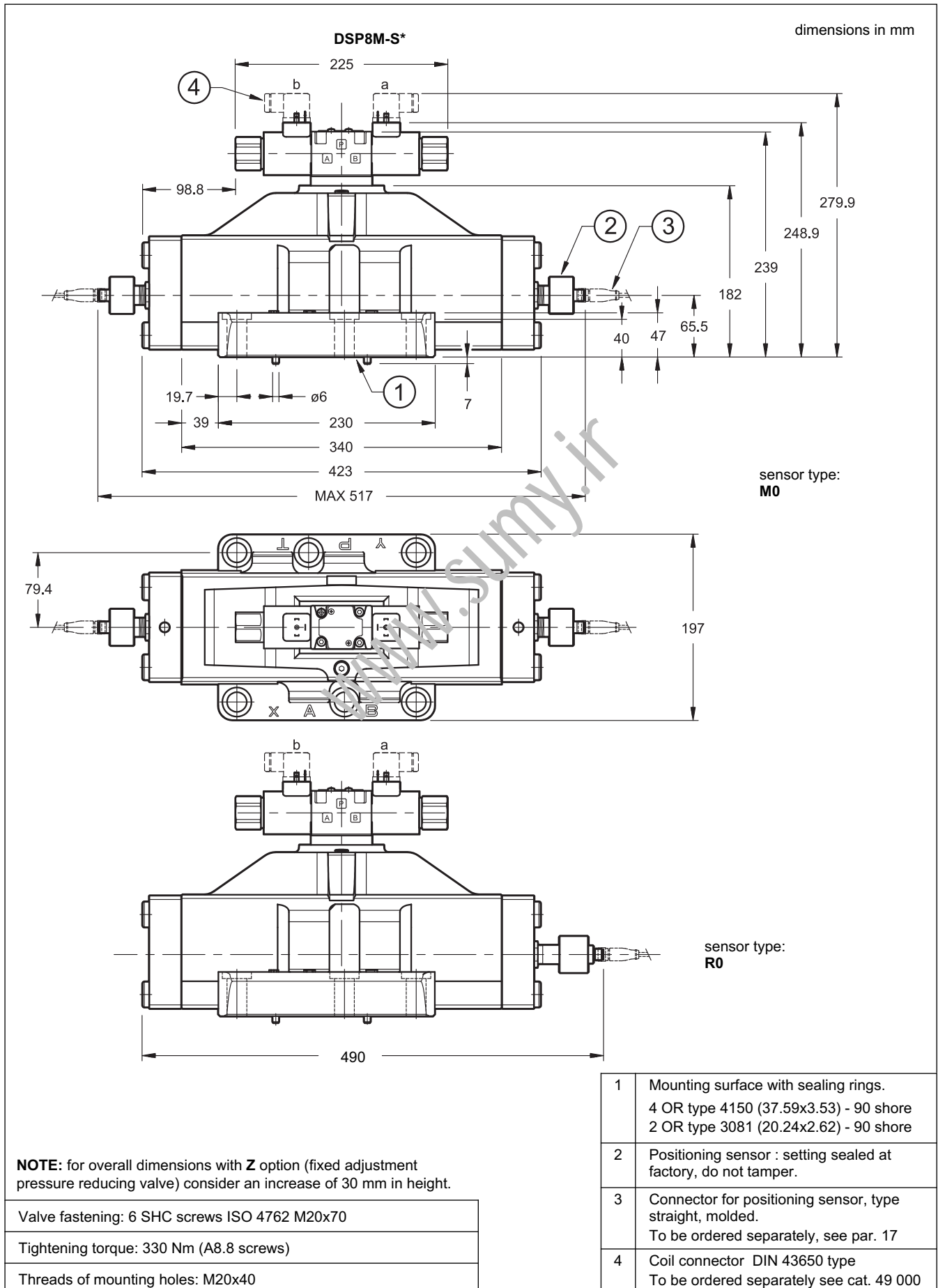

14 - MOUNTING SURFACES

DS3M
ISO 4401-03-02-0-05
(CETOP 4.2-4-03-350)

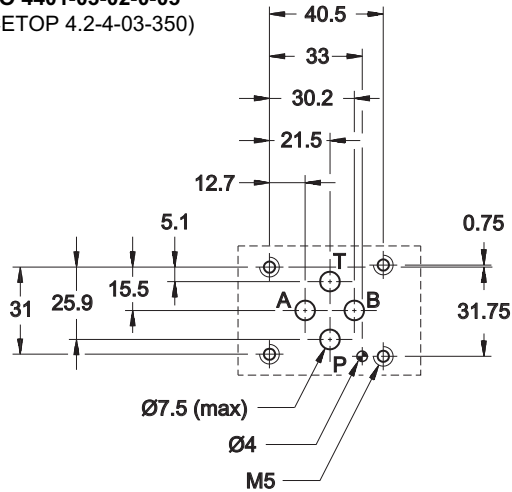

DS5M
ISO 4401-05-04-0-05
(CETOP 4.2-4-05-320)

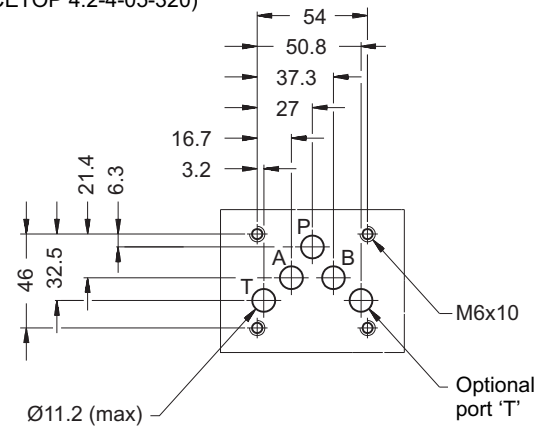

DSP5M
CETOP 4.2-4 P05-320

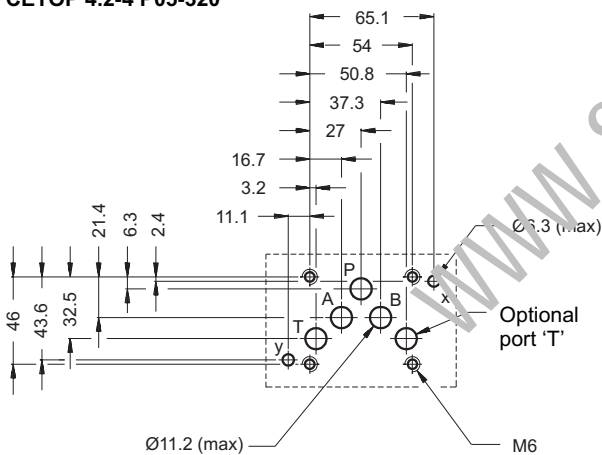

DSP5RM
ISO 4401-05-05-0-05
(CETOP 4.2-4 R05-320)

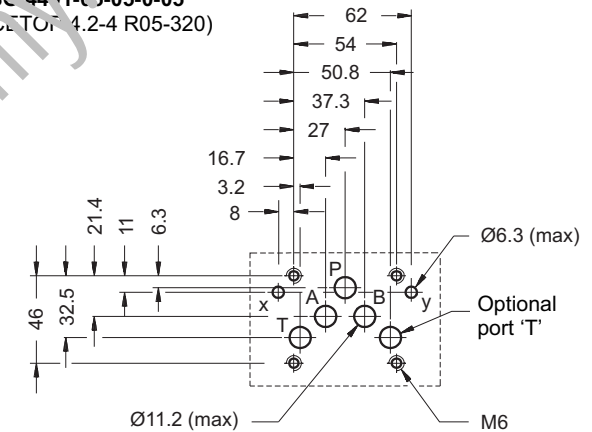

DSP7M
ISO 4401-07-07-0-05
(CETOP 4.2-4-07-350)

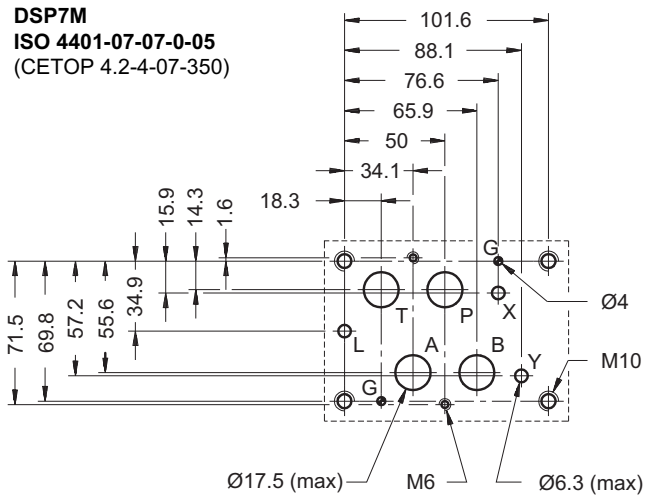

DSP8M
ISO 4401-08-08-0-05
(CETOP 4.2-4-08-350)

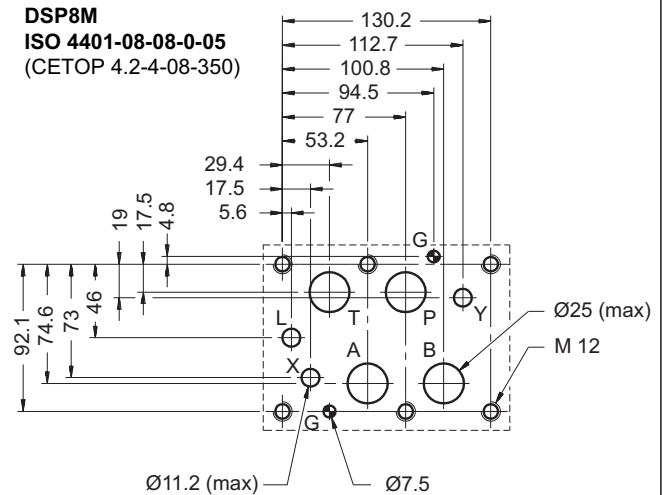

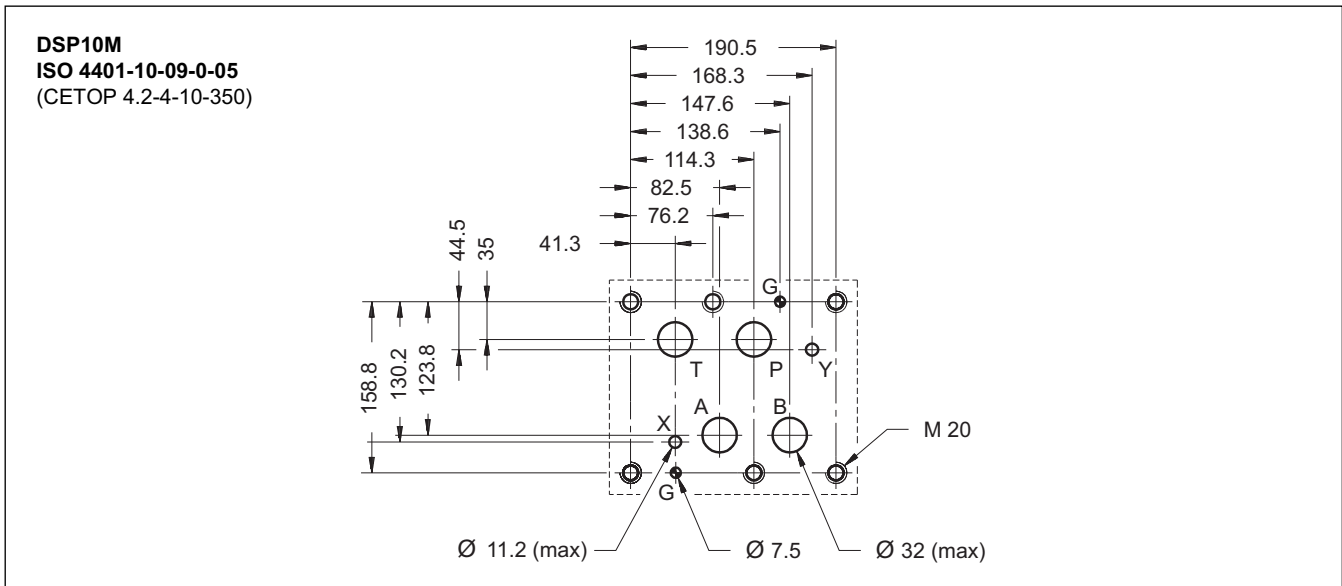

15 - POSITIONING SENSORS



WARNING ! The disassembly of the valve is not allowed. The sensors must not be unscrewed or tampered with in any way.

The M0 and M_B versions have two positioning sensors; consider that the connection scheme shown must be done for each sensor.

R0 CONNECTION SCHEME

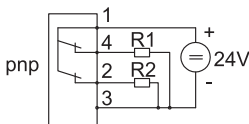

Pin	Values	Function
1	+24V	Supply
2	NC	Normal Closed -
3	0V	-
4	NC	Normal Closed +

M CONNECTION SCHEME

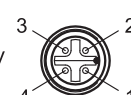
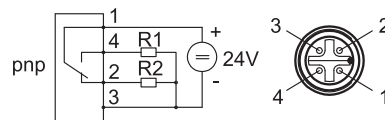

Pin	Values	Function
1	+24V	Supply
2	NC	Normal Closed
3	0V	-
4	NO	Normal Open

ELECTRICAL CHARACTERISTICS		
Operating voltage range	V DC	20 ÷ 32
Absorbed current	A	0.4
Max output load	mA	400
Output		2 PNP
Electric protections	polarity inversion short circuit	
Hysteresis	mm	≤ 0.1
Operating temperature range	°C	-25 / +80
Class of protection according to CEI EN 60529 standards (atmospheric agents)		IP65
EMC Electromagnetic compatibility	DIN EN 61000-6-1/2/3/4	

16 - SWITCHING LOGICS

DIPLOMATIC offers a wide range of available positions to be monitored, and for the pilot operated valve there are even monitoring with redundant signal.

16.1 - R0 monitoring

Central position monitored with one positioning sensor.

Available on both direct and pilot operated valves;
spool type S*

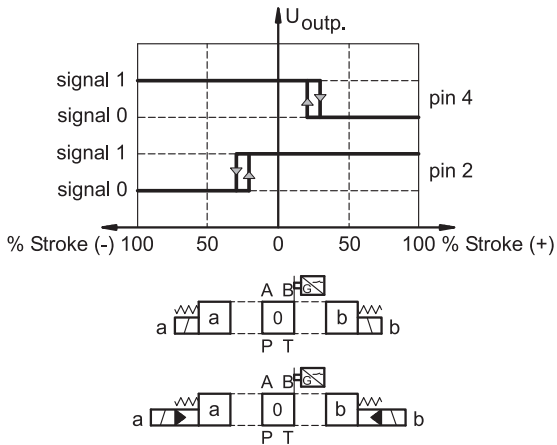

16.2 - MA monitoring

Energized position monitored with one positioning sensor.

Available on both direct and pilot operated valves;
spool type SA*, TA, TA02, TA100

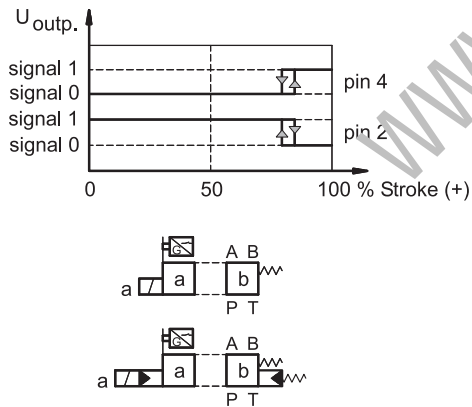

De-energized position monitored with one positioning sensor.

Available on both direct and pilot operated valves;
spool type SB*, TB, TB02, TB100

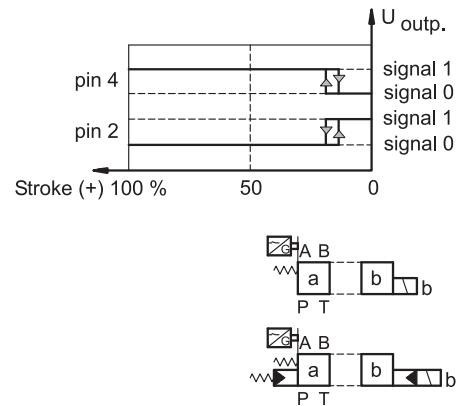

Position 'a' monitored with one positioning sensor.

Available on pilot operated valves only;
spool type RK

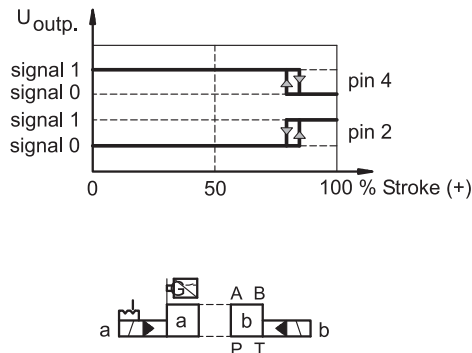

16.3 - MB monitoring

De-energized position monitored with one positioning sensor.

Available on both direct and pilot operated valves;
spool type SA*, TA, TA02, TA100

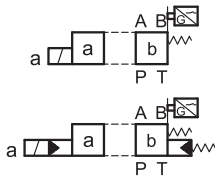
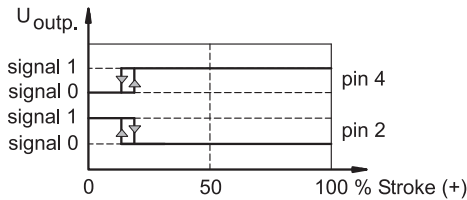

Energized position monitored with one positioning sensor.

Available on both direct and pilot operated valves;
spool type SB*, TB, TB02, TB100

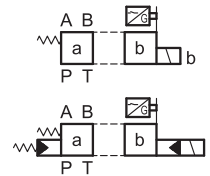
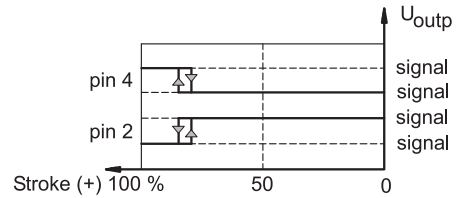

Position 'b' monitored with one positioning sensor.

Available on pilot operated valves only;
spool type RK

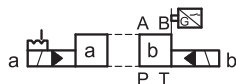
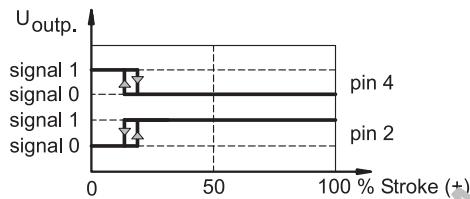

16.4 - M0 monitoring

Central position monitored by two separate positioning sensors.

Available on pilot operated valves only;
spool type S*

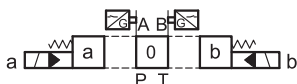
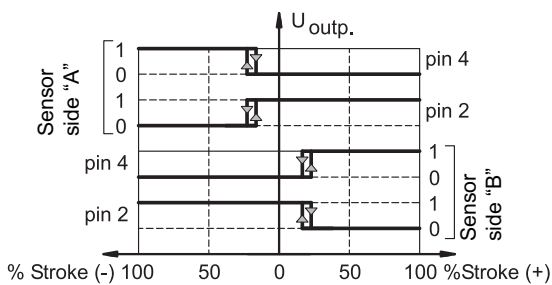

16.5 - MAB monitoring

Both external positions monitored by two separate positioning sensors.

Available on pilot operated valves only;
spool type S*

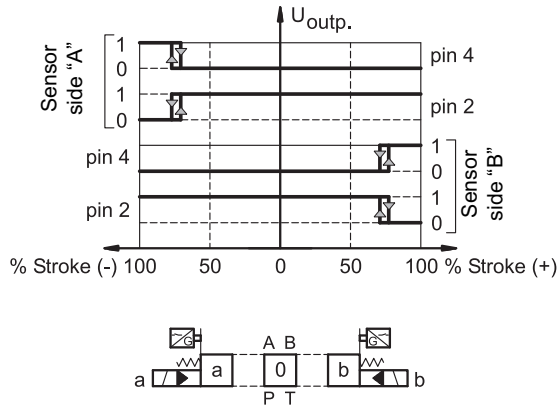

De-energized position monitored on side A.
Energized position monitored on side B.
Available on pilot operated valves only;
spool type SA1, TA, TA100

Energized position monitored on side A.
De-energized position monitored on side B.
Available on pilot operated valves only;
spool type SB1, TB, TB100

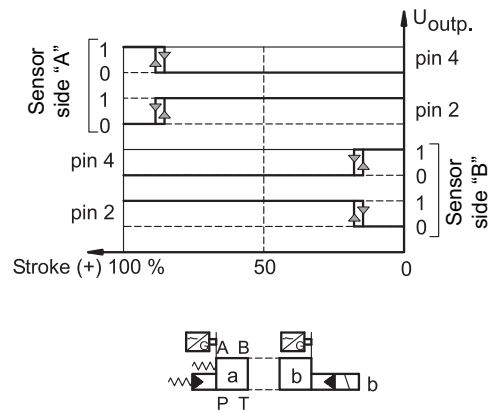
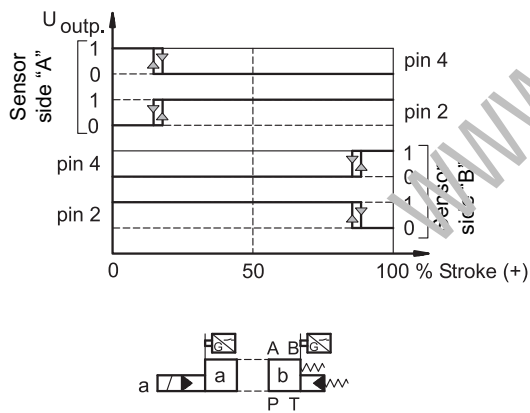

17 - SENSOR CONNECTORS

The female connectors for position switches can be ordered separately, by specifying the descriptions here below, depending on the desired type.

STRAIGHT CONNECTOR, MOLDED CABLE, PRE-WIRED

description: ECM4S/M12L/10

Protection class: IP68
 Cable: 4 conductors 0.34 mm²
 length 5 mt - Ø 4.7 mm
 Cable material: polyurethane resin (oil resistant)
 Without LED.

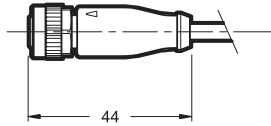

ANGLED CONNECTOR, MOLDED CABLE, PRE-WIRED

description: ECM4S/M12S/10

Protection class: IP68
 Cable: 4 conductors 0.34 mm²
 length 5 mt - Ø 4.7 mm
 Cable material: polyurethane resin (oil resistant)
 Without LED.

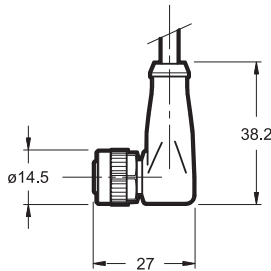

ANGLED CONNECTOR, UNASSEMBLED

Circular connector with screw locking; strain relief by means of clamping cage.

description: EC4S/M12S/10

Protection class: IP67
 IEC 61076-2-101 (Ed. 1)
 IEC 60947-5-2
 Conductor size: max 0.75 mm²
 Cable gland: PG7
 suitable cables: 4 + 6 mm²
 Case material: polyamide (nylon)
 Without LED.

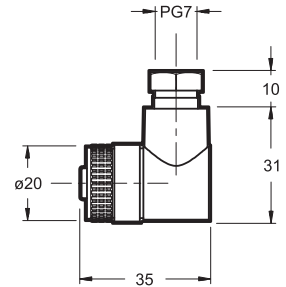

18 - HYDRAULIC FLUIDS

Use mineral oil-based hydraulic fluids HL or HM type, according to ISO 6743-4. For these fluids, use NBR seals (code N). For fluids HFDR type (phosphate esters) use FPM seals (code V). For the use of other fluid types such as HFA, HFB, HFC, please consult our technical department.

Using fluids at temperatures higher than 80 °C causes a faster degradation of the fluid and of the seals characteristics. The fluid must be preserved in its physical and chemical characteristics.

19 - INSTALLATION



WARNING! These valves must be installed and commissioned by qualified personnel only. Before starting any installation, commissioning or maintenance is mandatory read the manual of use and maintenance, delivered together with the valve.

Configurations with centering and recall springs can be mounted in any position; The RK versions, without springs and with mechanical detent, must be mounted with the longitudinal axis horizontal.

Valve fastening takes place by means of screws or tie rods, laying the valve on a lapped surface, with values of planarity and smoothness that are equal to or better than those indicated in the drawing.

If the minimum values of planarity or smoothness are not met, fluid leakages between valve and mounting surface can easily occur.

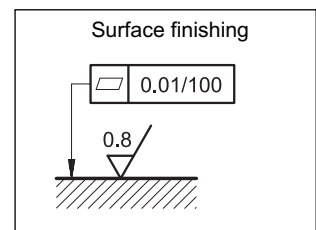

20 - SUBPLATES

(see catalogue 51 000)

	DS3M	DS5M	DSP5M	DSP7M	DSP8M
Type with rear ports	PMMD-AI3G	PMD4-AI4G	PME4-AI5G	PME07-AI6G	-
Type with side ports	PMMD-AL3G	PMD4-AL4G	PME4-AL5G	PME07-AL6G	PME5-AL8G
P, T, A, B ports dimensions	3/8" BSP	3/4" BSP (PMD4-AI4G) 1/2" BSP (PMD4-AL4G)	3/4" BSP	1" BSP	1 1/2" BSP
X, Y ports dimensions	-	-	1/4" BSP	1/4" BSP	1/4" BSP



DIPLOMATICO OLEODINAMICA S.p.A.
 20015 PARABIAGO (MI) • Via M. Re Depaolini 24
 Tel. +39 0331.895.111
 Fax +39 0331.895.339
 www.diplomatic.com • e-mail: sales.exp@diplomatic.com